

Specifications Guide

Agilent Technologies

ESA-E Series Spectrum Analyzers

This manual provides documentation for the following instruments:

Agilent Technologies

E4401B (9 kHz – 1.5 GHz)

E4402B (9 kHz – 3.0 GHz)

E4404B (9 kHz – 6.7 GHz)

E4405B (9 kHz – 13.2 GHz)

E4407B (9 kHz – 26.5 GHz)



Agilent Technologies

Manufacturing Part Number: E4401-90242

Printed in USA

February 2001

Supersedes: E4401-90225

© Copyright 2000 Agilent Technologies

The information contained in this document is subject to change without notice.

Agilent Technologies makes no warranty of any kind with regard to this material, including but not limited to, the implied warranties of merchantability and fitness for a particular purpose. Agilent Technologies shall not be liable for errors contained herein or for incidental or consequential damages in connection with the furnishing, performance, or use of this material.

The following safety symbols are used throughout this manual. Familiarize yourself with the symbols and their meaning before operating this instrument.

WARNING

***Warning* denotes a hazard. It calls attention to a procedure which, if not correctly performed or adhered to, could result in injury or loss of life. Do not proceed beyond a warning note until the indicated conditions are fully understood and met.**

WARNING

This is a Safety Class 1 Product (provided with a protective earthing ground incorporated in the power cord). The mains plug shall only be inserted in a socket outlet provided with a protected earth contact. Any interruption of the protective conductor inside or outside of the product is likely to make the product dangerous. Intentional interruption is prohibited.

WARNING

If this product is not used as specified, the protection provided by the equipment could be impaired. This product must be used in a normal condition (in which all means for protection are intact) only.

CAUTION

Caution denotes a hazard. It calls attention to a procedure that, if not correctly performed or adhered to, could result in damage to or destruction of the instrument. Do not proceed beyond a caution sign until the indicated conditions are fully understood and met.

WARNING This is a Safety Class 1 Product (provided with a protective earthing ground incorporated in the power cord. The mains plug shall only be inserted in a socket outlet provided with a protective earth contact. Any interruption of the protective conductor inside or outside of the product is likely to make the product dangerous. Intentional interruption is prohibited.

WARNING If this product is not used as specified, the protection provided by the equipment could be impaired. This product must be used in a normal condition (in which all means for protection are intact) only.

CAUTION Always use the three-prong ac power cord supplied with this product. Failure to ensure adequate earth grounding by not using this cord may cause product damage.

CAUTION This instrument has autoranging line voltage input, be sure the supply voltage is within the specified range.

Warranty

This Agilent Technologies instrument product is warranted against defects in material and workmanship for a period of one year from date of shipment. During the warranty period, Agilent Technologies Company will, at its option, either repair or replace products which prove to be defective.

For warranty service or repair, this product must be returned to a service facility designated by Agilent Technologies. Buyer shall prepay shipping charges to Agilent Technologies and Agilent Technologies shall pay shipping charges to return the product to Buyer. However, Buyer shall pay all shipping charges, duties, and taxes for products returned to Agilent Technologies from another country.

Agilent Technologies warrants that its software and firmware designated by Agilent Technologies for use with an instrument will execute its programming instructions when properly installed on that instrument. Agilent Technologies does not warrant that the operation of the instrument, or software, or firmware will be uninterrupted or error-free.

LIMITATION OF WARRANTY

The foregoing warranty shall not apply to defects resulting from improper or inadequate maintenance by Buyer, Buyer-supplied software or interfacing, unauthorized modification or misuse, operation outside of the environmental specifications for the product, or improper site preparation or maintenance.

NO OTHER WARRANTY IS EXPRESSED OR IMPLIED. AGILENT TECHNOLOGIES SPECIFICALLY DISCLAIMS THE IMPLIED WARRANTIES OF MERCHANTABILITY AND FITNESS FOR A PARTICULAR PURPOSE.

EXCLUSIVE REMEDIES

THE REMEDIES PROVIDED HEREIN ARE BUYER'S SOLE AND EXCLUSIVE REMEDIES. AGILENT TECHNOLOGIES SHALL NOT BE LIABLE FOR ANY DIRECT, INDIRECT, SPECIAL, INCIDENTAL, OR CONSEQUENTIAL DAMAGES, WHETHER BASED ON CONTRACT, TORT, OR ANY OTHER LEGAL THEORY.

Where to Find the Latest Information

Documentation is updated periodically. For the latest information about Agilent Spectrum Analyzers, including firmware upgrades and application information, please visit the following Internet URL: <http://www.agilent.com/go/esa>.

Contents

1. Agilent E4401B Specifications and Characteristics

About This Chapter	2
Frequency	4
Amplitude	11
Options	23
Time Gated Spectrum Analysis (Option 1D6)	23
Tracking Generator (Option 1DN or 1DQ)	24
FM Demodulation (Option BAA)	28
TV Trigger and Picture On Screen (Option B7B)	29
General	30
Inputs and Outputs	35
Internal	35
Front Panel	35
Rear Panel	36
Regulatory Information	41
Declaration of Conformity	42

2. Agilent E4402B Specifications and Characteristics

About This Chapter	44
Frequency	46
Amplitude	53
Options	65
Time Gated Spectrum Analysis (Option 1D6)	65
Tracking Generator (Option 1DN)	66
Bluetooth FM Demodulation (Option 106)	70
Bluetooth Measurements Personality (Option 228)	71
FM Demodulation (Option BAA)	74
TV Trigger and Picture On Screen (Option B7B)	75
cdmaOne Measurement Personality (Option BAC)	76
GSM Measurement Personality (Option BAH)	86
General	94
Inputs and Outputs	99
Front Panel	99
Rear Panel	100
Regulatory Information	106
Declaration of Conformity	107

3. Agilent E4404B Specifications and Characteristics

About This Chapter	110
Frequency	112
Amplitude	119
Options	131
Time Gated Spectrum Analysis (Option 1D6)	131
Tracking Generator (Option 1DN)	132
Bluetooth FM Demodulation (Option 106)	136

Contents

Bluetooth Measurements Personality (Option 228)	137
FM Demodulation (Option BAA)	140
TV Trigger and Picture On Screen (Option B7B)	141
cdmaOne Measurement Personality (Option BAC)	142
GSM Measurement Personality (Option BAH)	150
General	158
Inputs and Outputs	163
Front Panel	163
Rear Panel	164
Regulatory Information	170
Declaration of Conformity	171
4. Agilent E4405B Specifications and Characteristics	
About This Chapter	174
Frequency	176
Amplitude	184
Options	197
Time Gated Spectrum Analysis (Option 1D6)	197
Tracking Generator (Option 1DN)	198
Bluetooth FM Demodulation (Option 106)	202
Bluetooth Measurements Personality (Option 228)	203
FM Demodulation (Option BAA)	206
TV Trigger and Picture On Screen (Option B7B)	207
cdmaOne Measurement Personality (Option BAC)	208
GSM Measurement Personality (Option BAH)	216
General	224
Inputs and Outputs	229
Front Panel	229
Rear Panel	230
Regulatory Information	236
Declaration of Conformity	237
5. Agilent E4407B Specifications and Characteristics	
About This Chapter	240
Frequency	242
Amplitude	250
Options	266
Time Gated Spectrum Analysis (Option 1D6)	266
Tracking Generator (Option 1DN)	267
External Mixing (Option AYZ) [4E]	271
Bluetooth FM Demodulation (Option 106)	273
Bluetooth Measurements Personality (Option 228)	274
FM Demodulation (Option BAA)	277
TV Trigger and Picture On Screen (Option B7B)	278
cdmaOne Measurement Personality (Option BAC)	279

Contents

GSM Measurement Personality (Option BAH)	288
General	296
Inputs and Outputs	301
Front Panel	301
Rear Panel	302
Regulatory Information	309
Declaration of Conformity	310

1

Agilent E4401B Specifications and Characteristics

About This Chapter

This chapter contains specifications and characteristics for the Agilent E4401B spectrum analyzer. The distinction between specifications and characteristics is described as follows.

- Specifications describe the performance of parameters covered by the product warranty. (The temperature range is 0 °C to 55 °C, unless otherwise noted.)
- Characteristics describe product performance that is useful in the application of the product, but is not covered by the product warranty.
- Typical performance describes additional product performance information that is not covered by the product warranty. It is performance beyond specification that 80% of the units exhibit with a 95% confidence level over the temperature range 20 to 30 °C. Typical performance does not include measurement uncertainty.
- Nominal values indicate the expected performance, or describe product performance that is useful in the application of the product, but is not covered by the product warranty.

The following conditions must be met for the analyzer to meet its specifications.

- o The analyzer is within the one year calibration cycle.
- o If **Auto Align All** is selected:
 - After 2 hours of storage within the operating temperature range.
 - 5 minutes after the analyzer is turned on with sweep times less than 4 seconds.
- o If **Auto Align Off** is selected:
 - When the analyzer is at a constant temperature, within the operating temperature range, for a minimum of 90 minutes.
 - After the analyzer is turned on for a minimum of 90 minutes and **Align Now All** has been run.
 - When **Align Now All** is run:
 - Every hour
 - If the ambient temperature changes more than 3 °C
 - If the 10 MHz reference changes

- o If **Auto Align All but RF** is selected:
 - When the analyzer is at a constant temperature, within the operating temperature range, for a minimum of 90 minutes.
 - After the analyzer is turned on for a minimum of 90 minutes and **Align Now RF** has been run.
 - When **Align Now RF** is run:
 - Every hour
 - If the ambient temperature changes more than 3 °C

Frequency

	Specifications	Supplemental Information
Frequency Range		
50 Ω	9 kHz to 1.5 GHz	
50 Ω , Preamp On (<i>Option 1DS</i>)	100 kHz to 1.5 GHz	
75 Ω (<i>Option 1DP</i>)	1 MHz to 1.5 GHz	
75 Ω , Preamp On (<i>Option 1DS, 1DP</i>)	1 MHz to 1.5 GHz	

	Specifications	Supplemental Information
Frequency Reference		
Aging Rate	$\pm 2 \times 10^{-6}$ /year	$\pm 1.0 \times 10^{-7}$ /day, characteristic
Settability	$\pm 5 \times 10^{-7}$	
Temperature Stability	$\pm 5 \times 10^{-6}$	

	Specifications	Supplemental Information
High Stability Frequency Reference (<i>Option 1D5</i>)		
Aging Rate	$\pm 1 \times 10^{-7}$ /year	$\pm 5 \times 10^{-10}$ /day, 7-day average after being powered on for 7 days, characteristic
Settability	$\pm 1 \times 10^{-8}$	
Temperature Stability		
20 to 30 $^{\circ}\text{C}$	$\pm 1 \times 10^{-8}$	
0 to 55 $^{\circ}\text{C}$	$\pm 5 \times 10^{-8}$	
Warm-up (Internal frequency reference selected)		
After 5 minutes		$< \pm 1 \times 10^{-7}$ of final frequency, ^a characteristic
After 15 minutes		$< \pm 1 \times 10^{-8}$ of final frequency, ^a characteristic

a. Final frequency is defined as frequency 60 minutes after power-on with analyzer set to internal frequency reference.

	Specifications	Supplemental Information
Frequency Readout Accuracy (Start, Stop, Center, Marker)	$\pm((\text{frequency indication} \times \text{frequency reference error}^{\text{a}})$ $+ 0.5\% \text{ of span}$ $+ \frac{\text{span}}{\text{sweep points} - 1}$ $+ 15\% \text{ of RBW}$ $+ 10 \text{ Hz})$	

a. Frequency reference error = (aging rate × period of time since adjustment + settability + temperature stability).

	Specifications	Supplemental Information
Marker Frequency Counter Resolution Accuracy ^a	Selectable from 1 Hz to 100 kHz $\pm(\text{marker frequency} \times \text{frequency reference error}^{\text{b}} + \text{counter resolution})$	For RBW ≥ 1 kHz

a. Marker level to displayed noise level > 25 dB, RBW/ Span ≥ 0.002, frequency offset = 0 Hz.

b. Frequency reference error = (aging rate × period of time since adjustment + settability + temperature stability).

	Specifications	Supplemental Information
Frequency Span Range Resolution Accuracy ^a	0 Hz (zero span), 100 Hz to 1.5 GHz 2 Hz $\pm(0.5\% \text{ of span}$ $+ 2 \times \frac{\text{span}}{\text{sweep points} - 1})$	

a. Applies to each sweep segment.

	Specifications	Supplemental Information
Sweep Time		
Range		
Span > 0 Hz	1 ms to 4000 s ^a	$\frac{\text{sweep points} - 1}{100 \text{ kHz}}$ to 4000 s
Span = 0 Hz	10 μs to 4000 s ^{a,b}	
Tracking Generator On (Option 1DN or 1DQ)		
50 ms is the minimum sweep time		
Fast Time-domain Sweep (Option AYX) (For Span = 0 Hz, RBW ≥ 1 kHz)		
$\frac{\text{sweep points} - 1}{20 \text{ MHz}}$ to 4000 s		
Accuracy (Span = 0 Hz)		
10 μs to 4000 s ^{a,b}	±1%	
(Option AYX)	±1%	
50 ns to 4000 s ^{c,d}		
Sweep Trigger ^{e,f}		
Free Run, Single, Line, Video ^g , External, Delayed, Offset ^h		
(Option 1D6)	Add Gate	
(Option B7B)	Add TV	
Delayed Trigger ^{f,i}		
Range		
1 μs to 400 s		
Resolution		
$\frac{\text{delay in seconds}}{65000}$		
rounded up to nearest μs		
Accuracy		
±(500 ns + (0.01% of delay))		
Offset Trigger ^h		
Resolution		
$\frac{\text{sweep time}}{\text{sweep points} - 1}$		
Range		
±327 ms to ±12.3 ks		
Where ST = sweep time and SP = sweep points		
$\frac{-32766 \times \text{ST}}{\text{SP} - 1}$ to $\frac{(32766 - \text{SP}) \times \text{ST}}{\text{SP} - 1}$		

	Specifications	Supplemental Information
Fast Time-domain sweep (<i>Option AYX</i>) (For sweep times $\frac{\text{sweep points} - 1}{20 \text{ MHz}}$ to $\frac{\text{sweep points} - 1}{100 \text{ kHz}}$)	$\pm 1.23 \text{ ms}$ to $\pm 245 \text{ ms}$	$\frac{-32766 \times \text{ST}}{\text{SP} - 1}$ to $\frac{(32766 - \text{SP}) \times \text{ST}}{\text{SP} - 1}$

- a. For firmware revisions prior to A.04.00, 5 ms to 2000 s.
- b. For firmware revisions prior to A.05.00, 1 ms to 4000 s.
- c. For firmware revisions prior to A.04.00, 20 μs to 2000 s.
- d. For firmware revisions prior to A.05.00, 5 μs to 4000 s.
- e. Gate cannot be used simultaneously with delayed or TV trigger (*Option B7B*).
- f. Auto align is suspended in video, external, gate, and delayed trigger modes while waiting for a trigger event to occur.
- g. Unavailable when $\text{RBW} \leq 300 \text{ Hz}$ (*Option IDR*).
- h. For firmware revision A.04.00 or later.
- i. Delayed trigger is available with line, external trigger, and TV trigger (*Option B7B*).

	Specifications	Supplemental Information
Sweep (trace) Points		
Range		
Span > 0 Hz	101 to 8192 ^a	
Span = 0 Hz	2 to 8192 ^{a,b}	

- a. For firmware revisions prior to A.04.00, 401 points.
- b. For firmware revisions prior to A.05.00, 101 to 8192 points.

	Specifications	Supplemental Information
Resolution Bandwidth (RBW)		
Range		
-3 dB bandwidth	1 kHz to 3 MHz, in 1-3-10 sequence, 5 MHz	
-6 dB bandwidth (EMI)	9 kHz and 120 kHz	
(<i>Option IDR</i>)		
-3 dB bandwidth	Adds 10, 30, 100, 300 Hz	Only available in spans $\leq 5 \text{ MHz}$, sweep times $\geq \frac{\text{sweep points} - 1}{100 \text{ kHz}}$,
-6 dB bandwidth (EMI)	Add 200 Hz	and not usable with tracking generator on. (<i>Option 1DN</i> or <i>Option 1DQ</i>)

Agilent E4401B Specifications and Characteristics
Frequency

	Specifications	Supplemental Information
Accuracy		
1 kHz to 3 MHz RBW	±15%	
5 MHz RBW	±30%	
10 Hz to 300 Hz RBW (<i>Option 1DR</i>)	±10%	
Shape		
1 kHz to 5 MHz RBW		Synchronously tuned four poles, approximately Gaussian shape
10 Hz to 300 Hz RBW (<i>Option 1DR</i>)		Digital, approximately Gaussian shape
Selectivity (60 dB/3 dB bandwidth ratio)		
1 kHz to 5 MHz RBW		<15:1, characteristic
10 Hz to 300 Hz RBW (<i>Option 1DR</i>)		<5:1, characteristic

	Specifications	Supplemental Information
Video Bandwidth (VBW) (–3 dB)		
Range	30 Hz to 1 MHz in 1-3-10 sequence	3 MHz, characteristic
(<i>Option 1DR</i>)	Adds 1, 3, 10 Hz for RBW's <1 kHz	
Accuracy		±30%, characteristic
Shape		Post detection, single pole low-pass filter used to average displayed noise
		Video bandwidths below 30 Hz are digital bandwidths with anti-aliasing filtering.

	Specifications	Supplemental Information
Stability		
Noise Sidebands (Offset from CW signal with 1 kHz RBW, 30 Hz VBW and sample detector)		
≥1 kHz (<i>Option 1DR, 1D5</i>)		≤ -79 dBc/Hz, typical
≥10 kHz	≤ -93 dBc/Hz	≤ -95 dBc/Hz, typical
≥20 kHz	≤ -100 dBc/Hz	≤ -102 dBc/Hz, typical
≥30 kHz	≤ -104 dBc/Hz	≤ -106 dBc/Hz, typical
≥100 kHz	≤ -113 dBc/Hz	≤ -116 dBc/Hz, typical
Residual FM		
1 kHz RBW, 1 kHz VBW (<i>Option 1D5</i>)	≤150 Hz p-p in 100 ms ≤100 Hz p-p in 100 ms	
10 Hz RBW, 10 Hz VBW (<i>Option 1DR and 1D5</i>)	≤2 Hz p-p in 20 ms	
10 Hz RBW, 10 Hz VBW (<i>Option 1DR</i>)		≤10 Hz p-p in 20 ms, characteristic
System-Related Sidebands, offset from CW signal		
≥30 kHz	≤ -65 dBc	
Line-Related Sidebands, offset from CW signal (<i>Option 1DR</i>)		
<300 Hz		≤ -50 dBc, characteristic
>300 Hz to 30 kHz		≤ -55 dBc, characteristic

Noise Sidebands Normalized to 1 Hz Versus Offset from Carrier

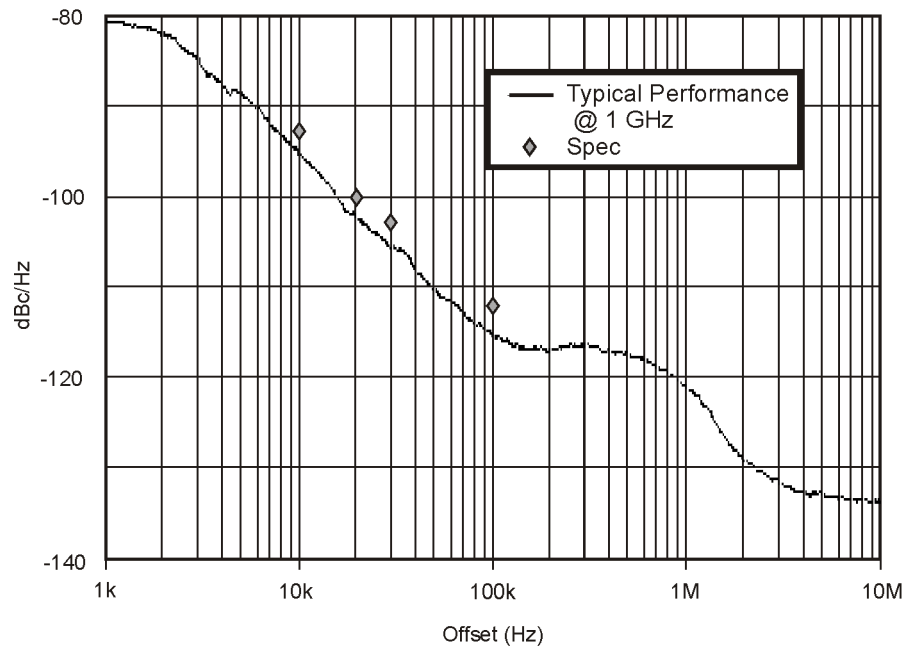

w720b

Amplitude

Amplitude specifications do not apply for the negative peak detector mode.

	Specifications	Supplemental Information
Measurement Range	Displayed Average Noise Level to Maximum Safe Input Level	
Input Attenuator Range	0 to 60 dB, in 5 dB steps	

	Specifications	Supplemental Information
Maximum Safe Input Level		
Input attenuator setting ≥ 15 dB		Signals $> +33$ dBm (2 W) or $+79$ dBmV (1 W) (<i>Option 1DP</i>) nominal may trigger input protection, which disconnects the input path.
Average Continuous Power or Peak Pulse Power		
50 Ω	+30 dBm (1 W)	
75 Ω (<i>Option 1DP</i>)	+75 dBmV (0.4 W)	
dc	100 Vdc	dc transients may momentarily trigger input protection.
Input attenuator setting < 15 dB		Signals $> +6$ dBm (4 mW) or $+61$ dBmV (15 mW) (<i>Option 1DP</i>) nominal may trigger input protection, which automatically increases input attenuation to 15 dB.
Average Continuous Power or Peak Pulse Power		
50 Ω	+3 dBm (2 mW)	
75 Ω (<i>Option 1DP</i>)	+59 dBmV (10 mW)	
dc	100 Vdc	dc transients may trigger input protection.

	Specifications	Supplemental Information
1 dB Gain Compression		
Total power at input mixer ^{a,b}		
50 MHz to 1.5 GHz		
50 Ω	0 dBm	
75 Ω (<i>Option 1DP</i>)	+46.75 dBmV	

	Specifications	Supplemental Information
Preamp On (<i>Option 1DS</i>) Total power at the preamp ^c		
50 Ω		-20 dBm, characteristic
75 Ω		+26.75 dBmV, characteristic

- Mixer power level (dBm) = input power (dBm) – input attenuation (dB).
- For resolution bandwidths 1 kHz to 30 kHz, the maximum input signal amplitude must be ≤ reference level +10 dB. (*Option 1DP: For resolution bandwidths 1 kHz to 30 kHz, the maximum input signal amplitude must be ≤ reference level +5 dB.*)
- Total power at the preamp = total power at the input (dBm).

	Specifications		Supplemental Information	
Displayed Average Noise Level (Input terminated, 0 dB attenuation, sample detector, Reference Level = -70 dBm) (75 Ω: Reference Level = -21.24 dBmV)				
50 Ω	1 kHz RBW 30 Hz VBW	10 Hz RBW 1 Hz VBW (<i>Option 1DR</i>)	1 kHz RBW 30 Hz VBW (typical)	10 Hz RBW 1 Hz VBW (<i>Option 1DR</i>) (typical)
400 kHz to 10 MHz	≤ -115 dBm	≤ -134 dBm	≤ -119 dBm	≤ -139 dBm
10 MHz to 500 MHz	≤ -119 dBm	≤ -138 dBm	≤ -121 dBm	≤ -141 dBm
500 MHz to 1.0 GHz	≤ -117 dBm	≤ -136 dBm	≤ -121 dBm	≤ -140 dBm
1.0 GHz to 1.5 GHz	≤ -114 dBm	≤ -133 dBm	≤ -118 dBm	≤ -138 dBm
50 Ω, Preamp On (<i>Option 1DS</i>)	1 kHz RBW 30 Hz VBW	10 Hz RBW 1 Hz VBW (<i>Option 1DR</i>)	1 kHz RBW 30 Hz VBW (typical)	10 Hz RBW 1 Hz VBW (<i>Option 1DR</i>) (typical)
400 kHz to 10 MHz	≤ -131 dBm	≤ -150 dBm	≤ -135 dBm	≤ -155 dBm
10 MHz to 500 MHz	≤ -135 dBm	≤ -154 dBm	≤ -136 dBm	≤ -156 dBm
500 MHz to 1.0 GHz	≤ -133 dBm	≤ -152 dBm	≤ -136 dBm	≤ -156 dBm
1.0 GHz to 1.5 GHz	≤ -131 dBm	≤ -150 dBm	≤ -135 dBm	≤ -155 dBm

	Specifications		Supplemental Information	
<i>75 Ω, (Option 1DP)</i>	1 kHz RBW 30 Hz VBW	10 Hz RBW 1 Hz VBW (<i>Option 1DR</i>)	1 kHz RBW 30 Hz VBW (typical)	10 Hz RBW 1 Hz VBW (<i>Option 1DR</i>) (typical)
1 MHz to 10 MHz	≤ -64 dBmV	≤ -83 dBmV	≤ -69 dBmV	≤ -89 dBmV
10 MHz to 500 MHz	≤ -66 dBmV	≤ -85 dBmV	≤ -70 dBmV	≤ -90 dBmV
500 MHz to 1.0 GHz	≤ -60 dBmV	≤ -79 dBmV	≤ -66 dBmV	≤ -85 dBmV
1.0 GHz to 1.5 GHz	≤ -56 dBmV	≤ -75 dBmV	≤ -62 dBmV	≤ -81 dBmV
<i>75 Ω, Preamp On (Option 1DP and 1DS)</i>	1 kHz RBW 30 Hz VBW	10 Hz RBW 1 Hz VBW (<i>Option 1DR</i>)	1 kHz RBW 30 Hz VBW (typical)	10 Hz RBW 1 Hz VBW (<i>Option 1DR</i>) (typical)
1 MHz to 10 MHz	≤ -80 dBmV	≤ -99 dBmV	≤ -83 dBmV	≤ -103 dBmV
10 MHz to 500 MHz	≤ -81 dBmV	≤ -100 dBmV	≤ -84 dBmV	≤ -104 dBmV
500 MHz to 1.0 GHz	≤ -81 dBmV	≤ -100 dBmV	≤ -84 dBmV	≤ -104 dBmV
1.0 GHz to 1.5 GHz	≤ -75 dBmV	≤ -94 dBmV	≤ -80 dBmV	≤ -100 dBmV

	Specifications	Supplemental Information
Display Range		
Log Scale	Ten divisions displayed; 0.1, 0.2, 0.5 dB/division and 1 to 20 dB/division in 1 dB steps	
RBW ≥ 1 kHz	Calibrated 0 to -85 dB from Reference Level	
RBW ≤ 300 Hz (<i>Option 1DR</i>)	Calibrated 0 to -120 dB ^a from Reference Level	
Linear Scale	Ten divisions	
Scale Units	dBm, dBmV, dBμV, dBμA, A, V, and W	
(<i>Option BAA</i>)	Add Hz	

a. 0 to -70 dB range when span = 0 Hz, or when IF Gain fixed:
(:DISPlay:WINDow:TRACe:Y[:SCALe]:LOG:RANGe:AUTO OFF).

	Specifications	Supplemental Information
<p>Marker Readout Resolution</p> <p>Log scale</p> <p>RBW \geq 1 kHz</p> <p>0 to -85 dB from ref level</p> <p>RBW \leq 300 Hz (<i>Option IDR</i>)</p> <p>0 to -120 dB from ref level</p> <p>Linear scale</p> <p>Fast Sweep Times for Zero Span</p> <p>(<i>Option AXX</i>)^a</p> <p>For sweep times</p> <p>$\frac{\text{sweep points} - 1}{20 \text{ MHz}}$ to</p> <p>$\frac{\text{sweep points} - 1}{100 \text{ kHz}}$</p> <p>Log</p> <p>0 to -85 dB from ref level</p> <p>Linear</p>	<p>0.04 dB</p> <p>0.04 dB</p> <p>0.01% of Reference Level</p> <p>0.3 dB</p> <p>0.3% of Reference Level for linear scale</p>	

a. For firmware revisions prior to A.04.00, 20 μ s to <5 ms.

	Specifications	Supplemental Information
<p>Frequency Response^a</p> <p>50 Ω</p> <p>9 kHz to 1.5 GHz</p> <p>10 dB attenuation</p> <p>20 to 30 $^{\circ}$C</p> <p>0 to 55 $^{\circ}$C</p> <p>0 dB, 5 dB, 15 to 60 dB attenuation</p>	<p>± 0.5 dB</p> <p>± 1.0 dB</p>	<p>± 1.0 dB, characteristic</p>

	Specifications	Supplemental Information
50 Ω Preamp On (<i>Option IDS</i>)		
100 kHz to 1.5 GHz		
0 dB attenuation		
20 to 30 °C	± 1.0 dB	
0 to 55 °C	± 1.5 dB	
5 dB to 20 dB attenuation		± 1.5 dB, characteristic
75 Ω (<i>Option IDP</i>)		
1 MHz to 1.5 GHz		
10 dB attenuation		
20 to 30 °C	± 0.5 dB	
0 to 55 °C	± 1.0 dB	
0, 5, 15 to 50 dB attenuation		± 1.0 dB, characteristic
55 to 60 dB attenuation		
1 MHz to 1 GHz		± 1.0 dB, characteristic
1 GHz to 1.5 GHz		± 1.25 dB, characteristic
75 Ω Preamp On (<i>Option IDS and IDP</i>)		
1 MHz to 1.5 GHz		
0 dB attenuation		
20 to 30 °C	± 1.5 dB	
0 to 55 °C	± 2.0 dB	
5 dB to 20 dB attenuation		± 2.0 dB, characteristic

a. Frequency response values are referenced to the amplitude at 50 MHz.

	Specifications	Supplemental Information
Input Attenuation Switching Uncertainty at 50 MHz		
Attenuator Setting		
0 dB to 5 dB	±0.3 dB	
10 dB	Reference	
15 dB	±0.3 dB	
20 to 60 dB attenuation	±(0.1 dB + 0.01 × Attenuator Setting)	

	Specifications	Supplemental Information
Preamp (Option IDS)		Refer also to Displayed Average Noise Level specification
Gain		+20 dB, nominal ^a
Noise figure		4 dB, characteristic

a. Amplifier is before the input attenuator.

	Specifications	Supplemental Information
Absolute Amplitude Accuracy		
At reference settings ^a	±0.30 dB	±0.10 dB, typical
Preamp On ^b (Option IDS)	±0.37 dB	±0.14 dB, typical
Overall Amplitude Accuracy ^c		
20 to 30 °C	± (0.54 dB + Absolute Frequency Response)	

- Settings are: reference level -25 dBm; (75 Ω reference level +28.75 dBmV); input attenuation 10 dB; center frequency 50 MHz; RBW 1 kHz; VBW 1 kHz; scale linear or log; span 2 kHz; sweep time coupled, sample detector, signal at reference level.
- Settings are: reference level -30 dBm; (75 Ω reference level +18.75 dBmV); input attenuation 0 dB; center frequency 50 MHz; RBW 1 kHz; VBW 1 kHz; scale linear or log; span 2 kHz; sweep time coupled, signal at reference level.
- For reference level 0 to -50 dBm; input attenuation 10 dB; RBW 1 kHz; VBW 1 kHz; scale log, log range 0 to -50 dB from reference level; sweep time coupled; signal input 0 to -50 dBm; span ≤20 kHz.

	Specifications	Supplemental Information
RF Input VSWR (at tuned frequency) Attenuator setting 50 Ω 0 to 5 dB attenuation 10 to 60 dB attenuation 75 Ω 1 MHz to 1.1 GHz 0 to 5 dB attenuation 10 to 60 dB attenuation 1.1 GHz to 1.5 GHz 0 to 60 dB attenuation Input protection is tripped Amptd Ref is On Auto Align All is selected		$\leq 1.55:1$, characteristic $\leq 1.35:1$, characteristic $\leq 1.55:1$, characteristic $\leq 1.35:1$, characteristic $\leq 2.0:1$, characteristic Open input, characteristic Open input, characteristic Open input momentarily during retrace, characteristic

	Specifications	Supplemental Information
Auto Alignment^a Sweep-to-sweep variation		± 0.1 dB, characteristic

a. Set **Auto Align** to **Off** and use **Align Now, All** to eliminate this variation.

	Specifications	Supplemental Information
Resolution Bandwidth Switching Uncertainty (at Reference Level) 1 kHz RBW 3 kHz to 3 MHz RBW 5 MHz RBW 10 Hz to 300 Hz RBW (<i>Option 1DR</i>)	Reference ± 0.3 dB ± 0.6 dB ± 0.3 dB	

	Specifications	Supplemental Information
Reference Level		
Range	-149.9 dBm to maximum mixer level + attenuator setting	
Resolution		
Log Scale	±0.1 dB	
Linear Scale	±0.12% of Reference Level	
50 Ω, Accuracy (at a fixed frequency, a fixed attenuator, and referenced to -35 dBm (-10 dBm, Preamp On (Option IDS)))		
Reference Level (dBm) – input attenuator setting (dB) + preamp gain (dB)		
-10 dBm to > -60 dBm	±0.3 dB	
-60 dBm to > -85 dBm	±0.5 dB	
-85 dBm to -90 dBm	±0.7 dB	
75 Ω (Option IDP), Accuracy (at a fixed frequency, a fixed attenuator, and referenced to 18.75 dBmV (38.75 dBmV, Preamp On (Option IDS)))		
Reference Level (dBmV) – input attenuator setting (dB) + preamp gain (dB)		
38.75 dBmV to > -11.25 dBmV	±0.3 dB	
-11.25 dBmV to > -26.25 dBmV	±0.5 dB	
-26.25 dBmV to -41.25 dBmV	±0.7 dB	

	Specifications	Supplemental Information
Display Scale Switching Uncertainty		
Switching between Linear and Log	±0.15 dB at reference level	
Log Scale Switching	No error	

	Specifications	Supplemental Information
Display Scale Fidelity		
Log Maximum Cumulative		
RBW \geq 1 kHz		
dB Below Reference Level		
0 dB Reference	0 dB	
> 0 to 10 dB	± 0.22 dB	± 0.08 dB, typical
> 10 to 20 dB	± 0.24 dB	± 0.09 dB, typical
> 20 to 30 dB	± 0.26 dB	± 0.10 dB, typical
> 30 to 40 dB	± 0.40 dB	± 0.23 dB, typical
> 40 to 50 dB	± 0.57 dB	± 0.35 dB, typical
> 50 to 60 dB	± 0.57 dB	± 0.35 dB, typical
> 60 to 70 dB	± 0.66 dB	± 0.39 dB, typical
> 70 to 80 dB	± 0.66 dB	± 0.46 dB, typical
> 80 to 85 dB	± 1.15 dB	± 0.79 dB, typical
RBW \leq 300 Hz (<i>Option 1DR</i>)		
Span > 0 Hz		
Auto range On		
0 to 98 dB below reference level	$\pm(0.3 \text{ dB} + 0.01 \times \text{dB from reference level})$	
> 98 to 120 dB below reference level		± 2.0 dB, characteristic
Auto range Off		
0 to 60 dB below reference level	$\pm(0.3 \text{ dB} + 0.015 \times \text{dB from reference level})$	
> 60 to 70 dB below reference level	± 1.5 dB	
Span = 0 Hz ^a		
0 to 60 dB below reference level	$\pm(0.3 \text{ dB} + 0.015 \times \text{dB from reference level})$	
> 60 to 70 dB below reference level	± 1.5 dB	

	Specifications	Supplemental Information
Log Incremental Accuracy		
0 to 80 dB ^b below reference level	±0.4 dB/4 dB	
Linear Accuracy	±2% of Reference Level	

- a. The SCPI command for auto range off is:
(:DISPlay:WINDow:TRACe:Y[:SCALe]:LOG:RANGe:AUTO OFF)
- b. 0 to -50 dB for RBWs ≤ 300 Hz and span = 0 Hz, or when auto ranging is off.

	Specifications	Supplemental Information
Spurious Responses		
50 Ω		
Second Harmonic Distortion		
Input Signal		
2 MHz to 750 MHz	< -75 dBc for -40 dBm signal at input mixer ^a	+35 dBm SHI (second harmonic intercept)
Preamp On (<i>Option 1DS</i>) 2 MHz to 750 MHz		0 dBm SHI, characteristic
Third Order Intermodulation Distortion		
2 MHz to 10 MHz		+14.5 dBm TOI (third order intercept), typical
10 MHz to 1.5 GHz	< -87 dBc ^b for two -30 dBm signals at input mixer ^a and >50 kHz separation.	+13.5 dBm ^b TOI +19 dBm TOI, typical
Preamp On (<i>Option 1DS</i>), 10 MHz to 1.5 GHz		-16 dBm TOI, characteristic
Other Input Related Spurious		
30 kHz ≤ offset ≤ 1200 MHz	< -65 dBc for -20 dBm signals at input mixer ^a ≤ 1.5 GHz.	
Offset > 1200 MHz	< -45 dBc for -20 dBm signal at input mixer ^a ≤ 1.5 GHz.	
Noise Floor Degradation		
Input frequency = 1210.7 MHz ± RBW		< -62 dBc for -45 dBm signal at input mixer ^a

- a. Mixer Power Level (dBm) = Input Power (dBm) – Input Attenuation (dB).
- b. For serial numbers < US39440413, < -80 dBc for two -30 dBm signals at the input mixer and > 50 kHz separation. +10 dBm TOI, +15 dBm, typical.

	Specifications	Supplemental Information
Spurious Responses		
<i>75 Ω, (Option 1DP)</i>		
Second Harmonic Distortion		
Input signal		
2 MHz to 750 MHz	< -75 dBc for +8.75 dBmV signal at input mixer ^a	
Preamp On (<i>Option 1DS</i>), 2 MHz to 750 MHz		< -40 dBc for +8.75 dBmV signal at the Input with 0 dB input attenuation, characteristic
Third Order Intermodulation Distortion		
10 MHz to 1.5 GHz	< -80 dBc for two +18.75 dBmV signals at input mixer ^a and >50 kHz separation.	
Preamp On (<i>Option 1DS</i>), 10 MHz to 1.5 GHz		< -28 dBc for two +18.75 dBmV signals at the Input with 0 dB input attenuation and > 50 kHz separation, characteristic
Other Input Related Spurious		
30 kHz ≤ offset ≤1200 MHz	< -65 dBc for +28.75 dBmV signal at input mixer ^a ≤1.5 GHz.	
Offset >1200 MHz	< -45 dBc, for +28.75 dBmV signal at input mixer ^a ≤1.5 GHz.	
Noise Floor Degradation		
Input frequency = 1210.7 MHz ± RBW		< -62 dBc, for +3.75 dBmV signal at input mixer ^a

a. Mixer Power Level (dBmV) = Input Power (dBmV) – Input Attenuation (dB)

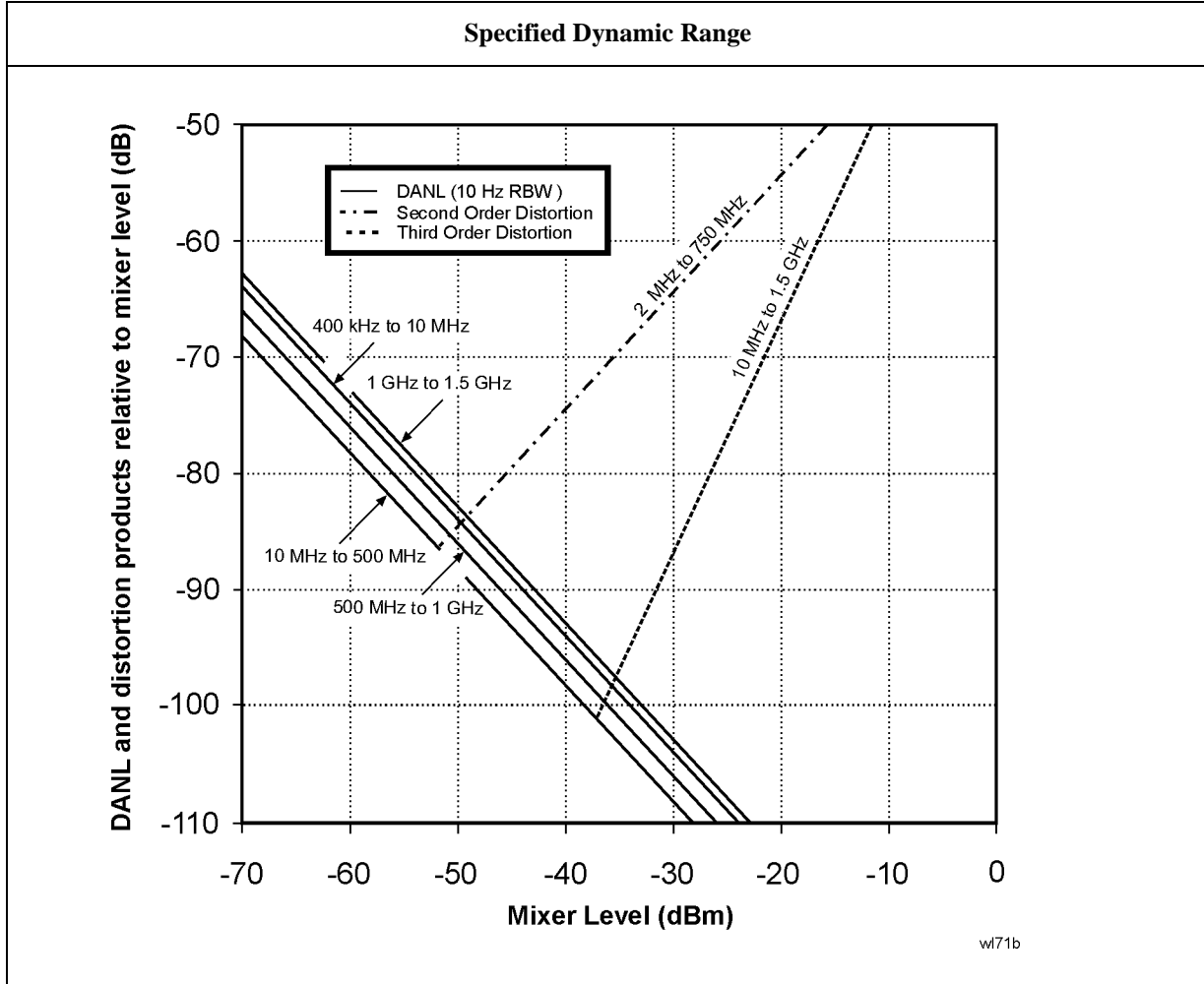

	Specifications	Supplemental Information
Residual Responses (Input terminated and 0 dB attenuation) 50 Ω 150 kHz to 1.5 GHz 75 Ω , (Option 1DP) 1 MHz to 1.5 GHz	< -90 dBm < -36 dBmV	

Options

Time Gated Spectrum Analysis (Option 1D6)

	Specifications	Supplemental Information
Gate Delay		
Range	1 μ s to 400 s	
Accuracy	$\pm(500 \text{ ns} + (0.01\% \times (\text{maximum of gate delay or length})))$	From gate trigger input to positive edge of gate output
Gate Length		
Range	1 μ s to 400 s	
Accuracy	$\pm(500 \text{ ns} + (0.01\% \times (\text{maximum of gate delay or length})))$	From positive edge to negative edge of gate output
Resolution	$((\text{maximum of gate delay or length in seconds})/65000)$ rounded up to nearest μ s	Dependent on the greater of gate delay or gate length
Additional Amplitude Error^a		
Log Scale	± 0.2 dB	
Linear Scale	$\pm 0.1\%$ of reference level	

a. While in gate mode.

Tracking Generator (Option 1DN or 1DQ)

	Specifications	Supplemental Information
Warm-up	5 minutes	

	Specifications	Supplemental Information
Output Frequency Range		
50 Ω (Option 1DN)	9 kHz to 1.5 GHz	
75 Ω (Option 1DQ)	1 MHz to 1.5 GHz	

	Specifications	Supplemental Information
Minimum Resolution BW	1 kHz	Not usable with resolution bandwidths ≤ 300 Hz (Option 1DR)

	Specifications	Supplemental Information
Output Power Level		
Range		
50 Ω (Option 1DN)		
0 to 55 $^{\circ}\text{C}$	0 to -70 dBm	
20 to 30 $^{\circ}\text{C}$	2 to -70 dBm	
75 Ω (Option 1DQ)	+42.75 to -27.25 dBmV	
Resolution	0.1 dB	
Absolute Accuracy (at 50 MHz with coupled source attenuator)		
50 Ω (Option 1DN) referenced to 0 dBm	± 0.5 dB	
75 Ω (Option 1DQ) referenced to +42.75 dBmV	± 1.5 dB	
Vernier		
Range	10 dB	
Accuracy (with coupled source attenuator)		
50 Ω (Option 1DN) referenced to 0 dBm	± 0.75 dB, for 0 to -10 dBm	

	Specifications	Supplemental Information
75 Ω (Option 1DQ) referenced to 42.75 dBmV	± 0.9 dB, for +42.75 to +32.75 dBmV	
Output Attenuator Range	0 to 60 dB in 10 dB steps	

	Specifications	Supplemental Information
Maximum Safe Reverse Level		
50 Ω (Option 1DN) ^a		+20 dBm (0.1 W), 100 Vdc, characteristic
75 Ω (Option 1DQ) ^a		+69 dBmV (0.1 W), 100 Vdc, characteristic

a. dc transients may trigger reverse power protection.

	Specifications	Supplemental Information
Output Power Sweep		
Range		
50 Ω (Option 1DN)	(-15 to 0 dBm) – (Source Attenuator Setting)	
75 Ω (Option 1DQ)	(27.75 to 42.75 dBmV) – (Source Attenuator Setting)	
Resolution	0.1 dB	
Accuracy (zero span) 50 Ω (Option 1DN)	<1.5 dB peak-to-peak	
75 Ω (Option 1DQ)	<1.8 dB peak-to-peak	

	Specifications	Supplemental Information
Output Flatness		
Referenced to 50 MHz, 0 dB attenuator		
50 Ω (Option 1DN)		
9 kHz to 10 MHz	± 2 dB	
10 MHz to 1.5 GHz	± 1.5 dB	
75 Ω (Option 1DQ)		
1 MHz to 10 MHz	± 2.5 dB	
10 MHz to 1.5 GHz	± 2 dB	

	Specifications	Supplemental Information
Spurious Outputs 50 Ω (Option 1DN) (0 dBm output) 75 Ω (Option 1DQ) (+42.75 dBmV output) Harmonic Spurs 9 kHz to 20 MHz 20 MHz to 1.5 GHz Non-harmonic Spurs	 	

	Specifications	Supplemental Information
Dynamic Range	Maximum Output Power Level – Displayed Average Noise Level	

	Specifications	Supplemental Information
Output Tracking Drift Swept Tracking Error		No error No error for coupled sweep times

	Specifications	Supplemental Information
RF Power-Off Residuals 50 Ω (Option 1DN) 100 kHz to 1.5 GHz 75 Ω (Option 1DQ) 1 MHz to 1.5 GHz		

	Specifications	Supplemental Information
Output Attenuator Repeatability		± 0.2 dB, characteristic

	Specifications	Supplemental Information
Output VSWR		
50 Ω (Option 1DN)		<2.5:1, characteristic
75 Ω (Option 1DQ)		<2.0:1, characteristic

	Specifications	Supplemental Information
Output Attenuator Accuracy		
0 dB	Reference	
10 dB		± 0.6 dB, characteristic
20 dB		± 0.9 dB, characteristic
30 dB		± 1.2 dB, characteristic
40 dB		± 1.5 dB, characteristic
50 dB		± 1.8 dB, characteristic
60 dB		± 2.1 dB, characteristic

Tracking Generator Output Accuracy 50 Ω (Option 1DN)
Relative Accuracy (Referred to 0 dBm) = Output Attenuator Accuracy + Vernier Accuracy + Output Flatness
Absolute Accuracy = Relative Accuracy (Referred to 0 dBm) + Absolute Accuracy at 50 MHz

Tracking Generator Output Accuracy 75 Ω (Option 1DQ)
Relative Accuracy (Referred to +42.75 dBmV) = Output Attenuator Accuracy + Vernier Accuracy + Output Flatness
Absolute Accuracy = Relative Accuracy (Referred to +42.75 dBmV) + Absolute Accuracy at 50 MHz

FM Demodulation (Option BAA)

The FM demodulation characteristics will apply after an **Align Now, FM Demod** has been run.

	Specifications	Supplemental Information
Optimum Input Level		$\geq (-60 \text{ dBm} + \text{attenuator setting} - \text{preamp gain})$ and within 30 dB of the reference level
FM Deviation		
Range		10 kHz to 1 MHz
Resolution		Provides 1 Hz display annotation resolution
FM Deviation Range		
10 kHz to 40 kHz		12 Hz, characteristic
>40 kHz to 200 kHz		60 Hz, characteristic
>200 kHz to 1 MHz		300 Hz, characteristic
Accuracy ^a		
FM Rate < FM BW/100, VBW $\geq (30 \times \text{FM Rate})$, RBW > the maximum of (30 \times FM deviation) or (30 \times FM Rate)		< (2% of FM deviation range + 2 \times Resolution), characteristic
Offset Error ^a		5% of FM Deviation Range + 300 Hz, characteristic
FM Bandwidth (-3 dB)		
FM Deviation Range		
10 kHz to 40 kHz		7.5 \times FM deviation range, characteristic
>40 kHz to 200 kHz		1.3 \times FM deviation range, characteristic
>200 kHz to 1 MHz		0.3 \times FM deviation range, characteristic

a. In time domain sweeps (span = 0 Hz).

TV Trigger and Picture On Screen (Option B7B)

Option BAA is required.

	Specifications	Supplemental Information
TV Trigger and Picture On Screen		TV Trigger initiates a sweep of the analyzer after the sync pulse of a selected line of a TV video field. Picture On Screen displays the TV picture on the analyzer display.
Amplitude Requirements TV Source: SA		Top 50% of linear display, characteristic
TV Source: EXT VIDEO IN		500 mVp-p to 2 Vp-p, characteristic
Compatible Standards	NTSC-M, NTSC-Japan, PAL-M, PAL-B,D,G,H,I, PAL-N, PAL-N Combination, SECAM-L	
Field Selection	Entire frame, even, odd	
Sync Polarity	Positive or negative	
TV Trigger		
Line Selection	1 to 525, or 1 to 625, standard dependent	

General

	Specifications	Supplemental Information
Temperature Range		
Operating	0 to 55 °C	Floppy disk 10 to 40 °C
Storage	-40 to 75 °C	

	Specifications	Supplemental Information
Audible Noise (ISO 7779)		
Sound Pressure at 25 °C		<40 dBa, (<4.6 Bels power)

	Specifications	Supplemental Information
Military Specification	Has been type tested to the environmental specifications of MIL-PRF-28800F class 3.	

	Specifications	Supplemental Information
EMI Compatibility	Conducted and radiated emission is in compliance with CISPR Pub. 11/1990 Group 1 Class A.	
<i>(Option 060)^a</i>	Conducted and radiated emission is in compliance with CISPR Pub. 11/1990 Group 1 Class B ^b .	

- a. Option 060 is not compatible with Option B7B nor Option 1DP.
b. Meets Class A performance during dc operation.

	Specifications	Supplemental Information
Immunity Testing		
Radiated Immunity		Testing was done at 3 V/m according to IEC 801-3/1984. When the analyzer tuned frequency is identical to the immunity test signal frequency, there may be signals of up to -60 dBm displayed on the screen.

	Specifications	Supplemental Information
Electrostatic Discharge		Air discharges of up to 8 kV were applied according to IEC 801-2/1991. Discharges to center pins of any of the connectors may cause damage to the associated circuitry.

	Specifications	Supplemental Information
Power Requirements		
ac Operation		
Voltage, frequency	90 to 132 Vrms, 47 to 440 Hz 195 to 250 Vrms, 47 to 66 Hz	
Power Consumption, On	<300 W	
Power Consumption, Standby	<5 W	
dc Operation		
Voltage	12 to 20 Vdc	
Power Consumption	<200 W	
Power Consumption, Standby	<100 mW	

	Specifications	Supplemental Information
Measurement Speed		
Local Measurement and Display Update rate ^{a,b}		
Sweep points = 101		≥ 50/s, characteristic
Sweep points = 401		≥ 35/s, characteristic
Remote Measurement and GPIB Transfer Rate ^{b,c,d}		
(Option A4H)		
Sweep points = 101		≥ 45/s, characteristic
Sweep points =401		≥ 30/s, characteristic

	Specifications	Supplemental Information
Demod Tune and Listen Demod <i>(Option BAA)</i> <i>(Option A4J or AYX)</i> <i>(Option BAA)</i>	AM Add FM	Internal speaker, front-panel earphone jack and front-panel volume control. An uncalibrated demodulated signal is available on the AUX VIDEO OUT connector at the rear panel. An uncalibrated demodulated signal is available on the EXT VIDEO OUT connector at the rear panel.

	Specifications	Supplemental Information
Weight (without options) Net Shipping		13.2 kg (29.1 lb), characteristic 25.1 kg (55.4 lb), characteristic

Dimensions

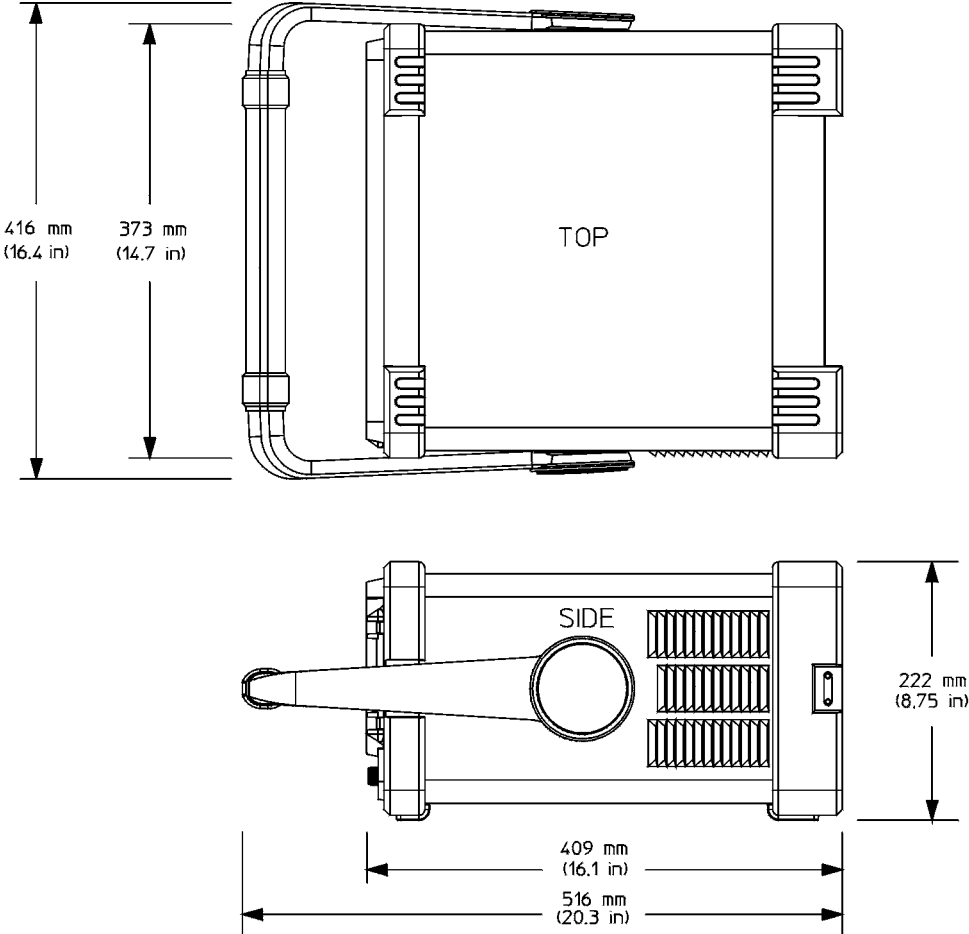

n1742a

Inputs and Outputs

Internal

	Specifications	Supplemental Information
Amptd Ref^a		Amplitude reference
Frequency		50 MHz
Frequency Accuracy		Frequency reference error ^b
50 Ω Amplitude		-25 dBm ^c , nominal
75 Ω Amplitude (<i>Option 1DP</i>)		+28.75 dBmV ^c , nominal

- Turn the amplitude reference signal on/off by pressing the keys: **Input/Output, Amptd Ref**.
- Frequency reference error = (aging rate \times period of time since adjustment + settability + temperature stability).
- The internal amplitude reference actual power is stored internally.

Front Panel

	Specifications	Supplemental Information
INPUT 50 Ω		
Connector	Type-N female	
Impedance		50 Ω , nominal
INPUT 75 Ω (<i>Option 1DP</i>)		
Connector	BNC female	
Impedance		75 Ω , nominal

	Specifications	Supplemental Information
RF OUT 50 Ω, (<i>Option 1DN</i>)		
Connector	Type-N female	
Impedance		50 Ω , nominal
RF OUT 75 Ω, (<i>Option 1DQ</i>)		
Connector	BNC female	
Impedance		75 Ω , nominal

	Specifications	Supplemental Information
PROBE POWER Voltage/Current		+15 Vdc, $\pm 7\%$ at 150 mA max., characteristic -12.6 Vdc $\pm 10\%$ at 150 mA max., characteristic

	Specifications	Supplemental Information
EXT KEYBOARD^a Connector	 6-pin mini-DIN	Used for entering screen titles and filenames only. Interface compatible with most IBM-compatible PC keyboards.

a. The feature is not implemented in firmware revisions prior to A.04.00.

	Specifications	Supplemental Information
Speaker		Front panel knob controls volume

	Specifications	Supplemental Information
Headphone Connector Power Output	 3.5 mm (1/8 inch) miniature audio jack	Front panel knob controls volume 0.2 W into 4 Ω , characteristic

Rear Panel

	Specifications	Supplemental Information
10 MHz REF OUT Connector Impedance Output Amplitude	 BNC female	 50 Ω , nominal >0 dBm, characteristic

	Specifications	Supplemental Information
10 MHz REF IN		
Connector	BNC female	Note: Analyzer noise sidebands and spurious response performance may be affected by the quality of the external reference used.
Impedance		50 Ω , nominal
Input Amplitude Range		-15 to +10 dBm, characteristic
Frequency		10 MHz, nominal

	Specifications	Supplemental Information
GATE TRIG/EXT TRIG IN		
Connector	BNC female	
External Trigger Input		
Trigger Level		Selectable positive or negative edge initiates sweep in EXT TRIG mode (5 V TTL)
Gate Trigger Input (<i>Option 1D6</i>)		
Minimum Pulse Width		>30 ns (5 V TTL)

	Specifications	Supplemental Information
GATE/HS SWP OUT		
Connector	BNC female	
High Sweep Output		
Level		High = sweep ^a ; Low = retrace (5 V TTL)
Gate Output (<i>Option 1D6</i>)		
Level		High = gate on; Low = gate off (5 V TTL)

a. High sweep may be high longer than the indicated sweep times.

	Specifications	Supplemental Information
VGA OUTPUT		
Connector	VGA compatible, 15-pin mini D-SUB	VGA (31.5 kHz horizontal, 60 Hz vertical sync rates, non-interlaced) Analog RGB
Format		
Resolution	640 × 480	

	Specifications	Supplemental Information
AUX IF OUT <i>(Option A4J or AYX)</i>		RBW ≥ 1 kHz
Connector	BNC female	21.4 MHz, nominal –10 dBm (uncorrected), characteristic 50 Ω, nominal
Frequency		
Amplitude (for signal at reference level and for reference levels – input attenuation + preamp gain of –10 to –70 dBm)		
Impedance		

	Specifications	Supplemental Information
AUX VIDEO OUT <i>(Option A4J or AYX)</i>		RBW ≥ 1 kHz
Connector	BNC female	0 to 1 V (uncorrected), characteristic
Amplitude Range (into >10 kΩ)		

	Specifications	Supplemental Information
HI SWP IN <i>(Option A4J or AYX)</i>		
Connector	BNC female	Open collector, low resets and holds the sweep (5 V TTL)
Input		

	Specifications	Supplemental Information
HI SWP OUT (Option A4J or AYZ)		
Connector	BNC female	
Output		High = sweep ^a , Low = retrace (5 V TTL)

a. High sweep may be high longer than the indicated sweep times.

	Specifications	Supplemental Information
SWP OUT (Option A4J or AYZ)		
Connector	BNC female	
Amplitude		0 to +10 V ramp, characteristic

	Specifications	Supplemental Information
GPIB Interface (Option A4H)		
Connector	IEEE-488 bus connector	
GPIB Codes		SH1, AH1, T6, SR1, RL1, PP0, DC1, C1, C2, C3 and C28

	Specifications	Supplemental Information
Serial Interface (Option IAX)		
Connector	9-pin D-SUB male	RS-232

	Specifications	Supplemental Information
Parallel Interface (Option A4H or IAX)		
Connector	25-pin D-SUB female	Printer port only

	Specifications	Supplemental Information
EXT VIDEO IN/TV TRIG OUT^a (<i>Option B7B or BAA</i>) Connector Impedance (<i>Option BAA without Option B7B</i>) (<i>Option BAA with Option B7B</i>) External Video Input Video Amplitude TV Trigger Output Amplitude	BNC Female (75 Ω)	EXT VIDEO IN is the Baseband composite video input for TV trigger and picture on screen. TV TRIG OUT is the TV trigger output. 75 Ω, nominal Feature not implemented 1 V _{p-p} , nominal, characteristic Positive edge indicates start of selected TV line after sync. pulse TTL (0 V and 3.4 V with 75 Ω series resistance), characteristic

- a. This connector is labelled EXT VIDEO IN on older spectrum analyzers and EXT VIDEO IN/TV TRIG OUT on newer spectrum analyzers.

	Specifications	Supplemental Information
EXT VIDEO OUT (<i>Option B7B or BAA</i>) Connector Impedance (<i>Option BAA without Option B7B</i>) Amplitude (<i>Option BAA with Option B7B</i>) Amplitude TV Source: SA TV Source and EXT VIDEO IN	BNC female (75 Ω)	Baseband video output RBW ≥ 1 kHz 75 Ω, nominal 0 to 1 V (uncorrected), characteristic 0 to 1 V (uncorrected), characteristic Same as level at EXT VIDEO IN/TV TRIG OUT, characteristic

Regulatory Information

CAUTION This product is designed for use in Installation Category II and Pollution Degree 2 per IEC 1010 and 664 respectively.

NOTE This product has been designed and tested in accordance with IEC Publication 1010, Safety Requirements for Electronic Measuring Apparatus, and has been supplied in a safe condition. The instruction documentation contains information and warnings which must be followed by the user to ensure safe operation and to maintain the product in a safe condition.



The CE mark is a registered trademark of the European Community (if accompanied by a year, it is the year when the design was proven).



The CSA mark is the Canadian Standards Association safety mark.

ISM 1-A

This is a symbol of an Industrial Scientific and Medical Group 1 Class A product. (CISPR 11, Clause 4)

Declaration of Conformity

DECLARATION OF CONFORMITY

According to ISO/IEC Guide 22 and CEN/CENELEC EN 45014

Manufacturer's Name: Agilent Technologies, Inc.

Manufacturer's Address: 1400 Fountaingrove Parkway
Santa Rosa, CA 95403-1799
USA

Declares that the products

Product Name: Spectrum Analyzer

Model Number: E4401B, E4402B, E4403B, E4404B,
E4405B, E4407B, E4408B, E4411B

Product Options: This declaration covers all options of the above products.

Conform to the following product specifications:

EMC: IEC 61326-1:1997+A1:1998 / EN 61326-1:1997+A1:1998

<u>Standard</u>	<u>Limit</u>
CISPR 11:1990 / EN 55011-1991	Group 1, Class A
IEC 61000-4-2:1995+A1998 / EN 61000-4-2:1995	4 kV CD, 8 kV AD
IEC 61000-4-3:1995 / EN 61000-4-3:1995	3 V/m, 80 - 1000 MHz
IEC 61000-4-4:1995 / EN 61000-4-4:1995	0.5 kV sig., 1 kV power
IEC 61000-4-5:1995 / EN 61000-4-5:1996	0.5 kV L-L, 1 kV L-G
IEC 61000-4-6:1996 / EN 61000-4-6:1998	3 V, 0.15 - 80 MHz
IEC 61000-4-11:1994 / EN 61000-4-11:1998	1 cycle, 100%

Safety: IEC 61010-1:1990 + A1:1992 + A2:1995 / EN 61010-1:1993 +A2:1995
CAN/CSA-C22.2 No. 1010.1-92

Supplementary Information:

The products herewith comply with the requirements of the Low Voltage Directive 73/23/EEC and the EMC Directive 89/336/EEC and carry the CE-marking accordingly.



Santa Rosa, CA, USA 17 April 2000

Greg Pfeiffer/Quality Engineering Manager

For further information, please contact your local Agilent Technologies sales office, agent or distributor.

About This Chapter

This chapter contains specifications and characteristics for the Agilent E4402B spectrum analyzer. The distinction between specifications and characteristics is described as follows.

- Specifications describe the performance of parameters covered by the product warranty. (The temperature range is 0 °C to 55 °C, unless otherwise noted.)
- Characteristics describe product performance that is useful in the application of the product, but is not covered by the product warranty.
- Typical performance describes additional product performance information that is not covered by the product warranty. It is performance beyond specification that 80% of the units exhibit with a 95% confidence level over the temperature range 20 to 30 °C. Typical performance does not include measurement uncertainty.
- Nominal values indicate the expected performance, or describe product performance that is useful in the application of the product, but is not covered by the product warranty.

The following conditions must be met for the analyzer to meet its specifications.

- o The analyzer is within the one year calibration cycle.
- o If **Auto Align All** is selected:
 - After 2 hours of storage within the operating temperature range.
 - 5 minutes after the analyzer is turned on with sweep times less than 4 seconds.
 - After the front-panel amplitude reference is connected to the INPUT, and **Align Now RF** has been run, after the analyzer is turned on. And, once every 24 hours, or if ambient temperature changes more than 30 °C¹.
- o If **Auto Align Off** is selected:
 - When the analyzer is at a constant temperature, within the operating temperature range, for a minimum of 90 minutes.
 - After the analyzer is turned on for a minimum of 90 minutes, the front panel amplitude reference has been connected to the INPUT, and **Align Now All** has been run.
 - When **Align Now All** is run:
 - Every hour
 - If the ambient temperature changes more than 3 °C

1. 10 °C if Preamp (*Option IDS*) is active.

- If the 10 MHz reference changes
- When **Align Now RF** is run (with the front-panel amplitude reference connected to the INPUT):
 - Every 24 hours
 - If the ambient temperature changes more than 30 °C¹
- o If **Auto Align All but RF** is selected:
 - When the analyzer is at a constant temperature, within the operating temperature range, for a minimum of 90 minutes.
 - After the analyzer is turned on for a minimum of 90 minutes, the front panel amplitude reference has been connected to the INPUT, and **Align Now RF** has been run.
 - When **Align Now RF** is run (with the front-panel amplitude reference connected to the INPUT):
 - Every hour
 - If the ambient temperature changes more than 3 °C

1. 10 °C if Preamp (*Option 1DS*) is active.

Frequency

	Specifications	Supplemental Information
Frequency Range	9 kHz to 3.0 GHz	
<i>(Option UKB)</i>		
dc Coupled	100 Hz to 3.0 GHz	30 Hz to 3.0 GHz, characteristic
ac Coupled	100 kHz to 3.0 GHz	
Preamp On <i>(Option 1DS)</i>	1 MHz to 3.0 GHz	

	Specifications	Supplemental Information
Frequency Reference		
Aging Rate	$\pm 2 \times 10^{-6}/\text{year}$	$\pm 1.0 \times 10^{-7}/\text{day}$, characteristic
Settability	$\pm 5 \times 10^{-7}$	
Temperature Stability	$\pm 5 \times 10^{-6}$	

	Specifications	Supplemental Information
High Stability Frequency Reference <i>(Option 1DS)</i>		
Aging Rate	$\pm 1 \times 10^{-7}/\text{year}$	$\pm 5 \times 10^{-10}/\text{day}$, 7-day average after being powered on for 7 days, characteristic
Settability	$\pm 1 \times 10^{-8}$	
Temperature Stability		
20 to 30 °C	$\pm 1 \times 10^{-8}$	
0 to 55 °C	$\pm 5 \times 10^{-8}$	
Warm-up (Internal frequency reference selected)		
After 5 minutes		$< \pm 1 \times 10^{-7}$ of final frequency, ^a characteristic
After 15 minutes		$< \pm 1 \times 10^{-8}$ of final frequency, ^a characteristic

a. Final frequency is defined as frequency 60 minutes after power-on with analyzer set to internal frequency reference.

	Specifications	Supplemental Information
Frequency Readout Accuracy (Start, Stop, Center, Marker)	$\pm((\text{frequency indication} \times \text{frequency reference error}^a)$ $+ 0.5\% \text{ of span}$ $+ \frac{\text{span}}{\text{sweep points} - 1}$ $+ 15\% \text{ of RBW}$ $+ 10 \text{ Hz})$	

a. Frequency reference error = (aging rate × period of time since adjustment + settability + temperature stability).

	Specifications	Supplemental Information
Marker Frequency Counter Resolution Accuracy ^a	Selectable from 1 Hz to 100 kHz $\pm(\text{marker frequency} \times \text{frequency reference error}^b + \text{counter resolution})$	For RBW ≥ 1 kHz

a. Marker level to displayed noise level > 25 dB, RBW/ Span ≥ 0.002, frequency offset = 0 Hz.

b. Frequency reference error = (aging rate × period of time since adjustment + settability + temperature stability).

	Specifications	Supplemental Information
Frequency Span Range Resolution Accuracy ^a	0 Hz (zero span), 100 Hz to 3 GHz 2 Hz $\pm(0.5\% \text{ of span}$ $+ 2 \times \frac{\text{span}}{\text{sweep points} - 1})$	

a. Applies to each sweep segment.

	Specifications	Supplemental Information
Sweep Time Range Span > 0 Hz Span = 0 Hz Tracking Generator On (Option 1DN)	1 ms to 4000 s ^a 10 μs to 4000 s ^{a,b}	$\frac{\text{sweep points} - 1}{100 \text{ kHz}}$ to 4000 s 50 ms is the minimum sweep time

Agilent E4402B Specifications and Characteristics
Frequency

	Specifications	Supplemental Information
Fast Time-domain Sweep (<i>Option AYX</i>) (For Span = 0 Hz, RBW ≥ 1 kHz)	50 ns to 4000 s ^{c,d}	$\frac{\text{sweep points} - 1}{20 \text{ MHz}}$ to 4000 s
DSP and fast ADC (<i>Option B7D</i>) (For Span = 0 Hz, RBW ≥ 1 kHz)	25 ns to 4000 s ^e	$\frac{\text{sweep points} - 1}{40 \text{ MHz}}$ to 4000 s
Accuracy (Span = 0 Hz)		
10 μs to 4000 s ^{a,b}	±1%	
(<i>Option AYX</i>)	±1%	
50 ns to 4000 s ^{c,d}		
(<i>Option B7D</i>)	±1%	
25 ns to 4000 s ^e		
Sweep Trigger ^{f,g}	Free Run, Single, Line, Video ^h , External, Delayed, Offset ⁱ	
(<i>Option 1D6</i>)	Add Gate	
(<i>Option B7B</i>)	Add TV	
Delayed Trigger ^{g,j}		
Range	1 μs to 400 s	
Resolution	$\frac{\text{delay in seconds}}{65000}$ rounded up to nearest μs	
Accuracy	±(500 ns + (0.01% of delay))	
Offset Trigger ⁱ		
Resolution	$\frac{\text{sweep time}}{\text{sweep points} - 1}$	
Range	±327 ms to ±12.3 ks	Where ST = sweep time and SP = sweep points $\frac{-32766 \times ST}{SP - 1}$ to $\frac{(32766 - SP) \times ST}{SP - 1}$
Fast Time-domain sweep (<i>Option AYX</i>) (For sweep times $\frac{\text{sweep points} - 1}{20 \text{ MHz}}$ to $\frac{\text{sweep points} - 1}{100 \text{ kHz}}$)	±1.23 ms to ±245 ms	$\frac{-32766 \times ST}{SP - 1}$ to $\frac{(32766 - SP) \times ST}{SP - 1}$

	Specifications	Supplemental Information
DSP and fast ADC (<i>Option B7D</i>) (For sweep times $\frac{\text{sweep points} - 1}{40 \text{ MHz}}$ to $\frac{\text{sweep points} - 1}{100 \text{ kHz}}$)	$\pm 13 \text{ ms}$ to $\pm 5.15 \text{ s}$	$\frac{-524031 \times \text{ST}}{\text{SP} - 1}$ to $\frac{(524031 - \text{SP}) \times \text{ST}}{\text{SP} - 1}$

- a. For firmware revisions prior to A.04.00, 5 ms to 2000 s.
- b. For firmware revisions prior to A.05.00, 1 ms to 4000 s.
- c. For firmware revisions prior to A.04.00, 20 μs to 2000 s.
- d. For firmware revisions prior to A.05.00, 5 μs to 4000 s.
- e. For firmware revisions prior to A.05.00, 2.5 μs to 4000 s.
- f. Gate cannot be used simultaneously with delayed or TV trigger (*Option B7B*).
- g. Auto align is suspended in video, external, gate, and delayed trigger modes while waiting for a trigger event to occur.
- h. Unavailable when $\text{RBW} \leq 300 \text{ Hz}$ (*Option 1DR*).
- i. For firmware revision A.04.00 or later.
- j. Delayed trigger is available with line, external trigger, and TV trigger (*Option B7B*).

	Specifications	Supplemental Information
Sweep (trace) Points		
Range		
Span > 0 Hz	101 to 8192 ^a	
Span = 0 Hz	2 to 8192 ^{a,b}	

- a. For firmware revisions prior to A.04.00, 401 points.
- b. For firmware revisions prior to A.05.00, 101 to 8192 points.

	Specifications	Supplemental Information
Resolution Bandwidth (RBW)		
Range		
-3 dB bandwidth	1 kHz to 3 MHz, in 1-3-10 sequence, 5 MHz	
-6 dB bandwidth (EMI)	9 kHz and 120 kHz	
(<i>Option 1DR</i>)		
-3 dB bandwidth	Adds 10, 30, 100, 300 Hz	Only available in spans $\leq 5 \text{ MHz}$, sweep times $\geq \frac{\text{sweep points} - 1}{100 \text{ kHz}}$,
-6 dB bandwidth (EMI)	Add 200 Hz	and not usable with tracking generator on. (<i>Option 1DN</i>)

Agilent E4402B Specifications and Characteristics
Frequency

	Specifications	Supplemental Information
Accuracy		
1 kHz to 3 MHz RBW	±15%	
5 MHz RBW	±30%	
10 Hz to 300 Hz RBW (<i>Option 1DR</i>)	±10%	
Shape		
1 kHz to 5 MHz RBW		Synchronously tuned four poles, approximately Gaussian shape
10 Hz to 300 Hz RBW (<i>Option 1DR</i>)		Digital, approximately Gaussian shape
Selectivity (60 dB/3 dB bandwidth ratio)		
1 kHz to 5 MHz RBW		<15:1, characteristic
10 Hz to 300 Hz RBW (<i>Option 1DR</i>)		<5:1, characteristic

	Specifications	Supplemental Information
Video Bandwidth (VBW) (–3 dB)		
Range	30 Hz to 1 MHz in 1-3-10 sequence	3 MHz, characteristic
(<i>Option 1DR</i>)	Adds 1, 3, 10 Hz for RBW's <1 kHz	
Accuracy		±30%, characteristic
Shape		Post detection, single pole low-pass filter used to average displayed noise
		Video bandwidths below 30 Hz are digital bandwidths with anti-aliasing filtering.

	Specifications	Supplemental Information
Stability		
Noise Sidebands (Offset from CW signal with 1 kHz RBW, 30 Hz VBW and sample detector)		
≥1 kHz (<i>Option 1DR, 1D5</i>)		≤ -78 dBc/Hz, typical
≥10 kHz	≤ -90 dBc/Hz	≤ -94 dBc/Hz, typical
≥20 kHz	≤ -100 dBc/Hz	≤ -105 dBc/Hz, typical
≥30 kHz	≤ -106 dBc/Hz	≤ -112 dBc/Hz, typical
≥100 kHz	≤ -119 dBc/Hz	≤ -122 dBc/Hz, typical
≥1 MHz	≤ -125 dBc/Hz	≤ -127 dBc/Hz, typical
≥5 MHz	≤ -127 dBc/Hz	≤ -129 dBc/Hz, typical
≥10 MHz	≤ -131 dBc/Hz	≤ -136 dBc/Hz, typical
<i>(Option 120)</i>		
≥1 MHz	≤ -133 dBc/Hz	≤ -136 dBc/Hz, typical
≥5 MHz	≤ -135 dBc/Hz	≤ -139 dBc/Hz, typical
≥10 MHz	≤ -137 dBc/Hz	≤ -141 dBc/Hz, typical
Residual FM		
1 kHz RBW, 1 kHz VBW <i>(Option 1D5)</i>	≤150 Hz p-p in 100 ms	
10 Hz RBW, 10 Hz VBW <i>(Option 1DR and 1D5)</i>	≤100 Hz p-p in 100 ms	
10 Hz RBW, 10 Hz VBW <i>(Option 1DR)</i>	≤2 Hz p-p in 20 ms	≤10 Hz p-p in 20 ms, characteristic
System-Related Sidebands, offset from CW signal		
≥30 kHz	≤ -65 dBc	
Line-Related Sidebands, offset from CW signal <i>(Option 1DR)</i>		
<300 Hz		≤ -50 dBc, characteristic
>300 Hz to 30 kHz		≤ -55 dBc, characteristic

Noise Sidebands Normalized to 1 Hz Versus Offset from Carrier

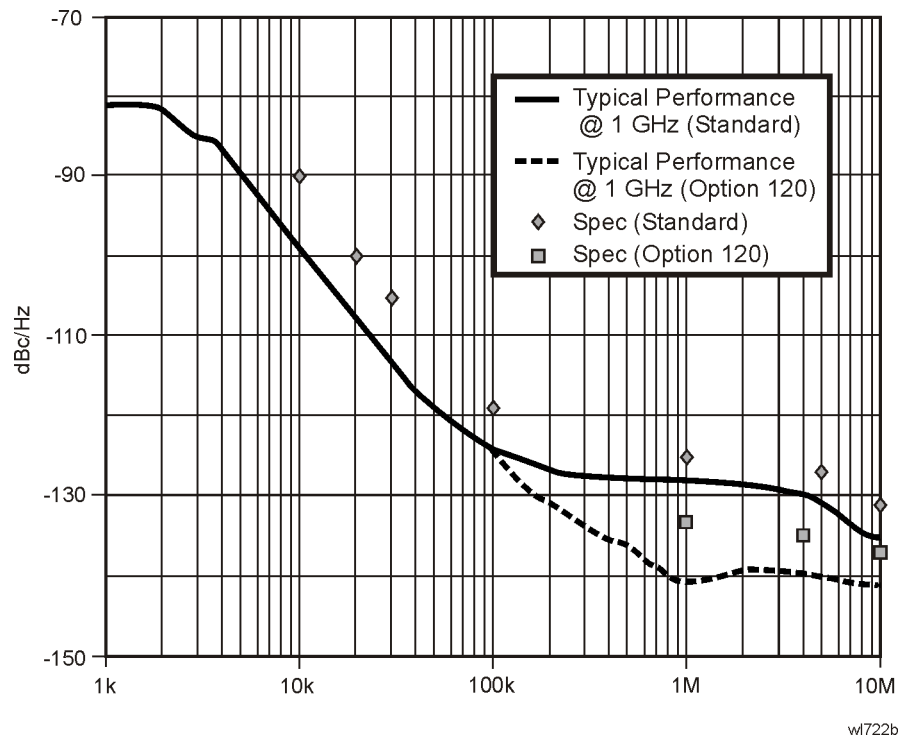

Amplitude

Amplitude specifications do not apply for the negative peak detector mode.

	Specifications	Supplemental Information
Measurement Range	Displayed Average Noise Level to Maximum Safe Input Level	
Input Attenuator Range	0 to 65 dB, in 5 dB steps	0 to 75 dB, in 5 dB steps, characteristic

	Specifications	Supplemental Information
Maximum Safe Input Level		
Average Continuous Power (Input attenuator setting ≥ 5 dB)	+30 dBm (1 W)	
Peak Pulse Power (for <10 μ sec pulse width, $<1\%$ duty cycle, and input attenuation ≥ 30 dB)	+50 dBm (100 W)	
dc (Option UKB)	100 Vdc	
dc coupled	0 Vdc	
ac coupled	50 Vdc	

	Specifications	Supplemental Information
1 dB Gain Compression		
Total power at input mixer ^{a,b} 50 MHz to 3.0 GHz	0 dBm	
Preamp On (Option IDS)		
Total power at the preamp ^c		-20 dBm, characteristic

- Mixer power level (dBm) = input power (dBm) – input attenuation (dB).
- For resolution bandwidths 1 kHz to 30 kHz, the maximum input signal amplitude must be \leq reference level +10 dB.
- Total power at the preamp (dBm) = total power at the input (dBm) – input attenuation (dB).

	Specifications		Supplemental Information		
Displayed Average Noise Level (Input terminated, 0 dB attenuation, sample detector, Reference Level = -70 dBm)					
		1 kHz RBW 30 Hz VBW	10 Hz RBW 1 Hz VBW (Option 1DR)	1 kHz RBW 30 Hz VBW (typical)	10 Hz RBW 1 Hz VBW (Option 1DR) (typical)
	30 Hz to 9 kHz (Option UKB)				≤ -93 dBm
	9 kHz to 100 kHz				≤ -109 dBm
	100 kHz to 1 MHz				≤ -135 dBm
	1 MHz to 10 MHz			≤ -117 dBm	≤ -136 dBm
	1 MHz to 10 MHz (Option 120)			≤ -120 dBm	≤ -139 dBm
	10 MHz to 1.0 GHz	≤ -117 dBm	≤ -136 dBm	≤ -120 dBm	≤ -140 dBm
	1.0 GHz to 2.0 GHz	≤ -116 dBm	≤ -135 dBm	≤ -120 dBm	≤ -140 dBm
	2.0 GHz to 3.0 GHz	≤ -114 dBm	≤ -133 dBm	≤ -120 dBm	≤ -140 dBm
	Preamp On (Option 1DS)	1 kHz RBW 30 Hz VBW	10 Hz RBW 1 Hz VBW (Option 1DR)	1 kHz RBW 30 Hz VBW (typical)	10 Hz RBW 1 Hz VBW (Option 1DR) (typical)
	0 to 55 °C				
	10 MHz to 1.0 GHz	≤ -132 dBm	≤ -151 dBm		
	1.0 GHz to 2.0 GHz	≤ -132 dBm	≤ -151 dBm		
	2.0 GHz to 3.0 GHz	≤ -129 dBm	≤ -148 dBm		
	20 to 30 °C				
	1 MHz to 10 MHz			≤ -134 dBm	≤ -152 dBm
	10 MHz to 1.0 GHz	≤ -133 dBm	≤ -152 dBm	≤ -136 dBm	≤ -156 dBm
	1.0 GHz to 2.0 GHz	≤ -134 dBm	≤ -153 dBm	≤ -136 dBm	≤ -156 dBm
	2.0 GHz to 3.0 GHz	≤ -132 dBm	≤ -151 dBm	≤ -134 dBm	≤ -154 dBm

	Specifications	Supplemental Information
Display Range		
Log Scale	Ten divisions displayed; 0.1, 0.2, 0.5 dB/division and 1 to 20 dB/division in 1 dB steps	
RBW \geq 1 kHz	Calibrated 0 to -85 dB from Reference Level	
RBW \leq 300 Hz (<i>Option IDR</i>)	Calibrated 0 to -120 dB ^a from Reference Level	
Linear Scale	Ten divisions	
Scale Units	dBm, dBmV, dB μ V, dB μ A, A, V, and W	
(<i>Option BAA, 106</i>)	Add Hz	

- a. 0 to -70 dB range when span = 0 Hz, or when IF Gain fixed:
(:DISPlay:WINDow:TRACe:Y[:SCALE]:LOG:RANGE:AUTO OFF).

	Specifications	Supplemental Information
Marker Readout Resolution		
Log scale		
RBW \geq 1 kHz	0 to -85 dB from ref level	0.04 dB
RBW \leq 300 Hz (<i>Option IDR</i>)	0 to -120 dB from ref level	0.04 dB
Linear scale		0.01% of Reference Level
Fast Sweep Times for Zero Span		
(<i>Option AYX</i>) ^a		
For sweep times		
$\frac{\text{sweep points} - 1}{20 \text{ MHz}}$ to		
$\frac{\text{sweep points} - 1}{100 \text{ kHz}}$		
Log	0 to -85 dB from ref level	0.3 dB
Linear		0.3% of Reference Level for linear scale

	Specifications	Supplemental Information
<p><i>(Option B7D)</i></p> <p>For sweep times $\frac{\text{sweep points} - 1}{40 \text{ MHz}}$ to $\frac{\text{sweep points} - 1}{100 \text{ kHz}}$</p> <p>Log 0 to -85 dB from ref level</p> <p>Linear</p>	<p>0.2 dB</p> <p>0.2% of Reference Level for linear scale</p>	

a. For firmware revisions prior to A.04.00, 20 μ s to <5 ms.

	Specifications	Supplemental Information
<p>Frequency Response^a</p> <p>10 dB attenuation</p> <p>9 kHz to 3.0 GHz</p> <p>20 to 30 °C</p> <p>0 to 55 °C</p> <p>800 MHz to 1.0 GHz^b</p> <p>20 to 30 °C</p> <p>0 to 55 °C</p> <p>1.7 GHz to 2.0 GHz^b</p> <p>20 to 30 °C</p> <p>0 to 55 °C</p> <p><i>(Option UKB)</i></p> <p>100 Hz to 3.0 GHz (dc coupled)</p> <p>20 to 30 °C</p> <p>0 to 55 °C</p> <p>30 Hz to 3.0 GHz (dc coupled)</p> <p>20 to 30 °C</p> <p>0 to 55 °C</p>	<p>± 0.46 dB</p> <p>± 0.76 dB</p> <p>± 0.46 dB</p> <p>± 0.76 dB</p> <p>± 0.46 dB</p> <p>± 0.76 dB</p> <p>± 0.5 dB</p> <p>± 1.0 dB</p>	<p>± 0.12 dB, typical</p> <p>± 0.04 dB, typical</p> <p>± 0.04 dB, typical</p> <p>± 0.5 dB, characteristic</p> <p>± 1.0 dB, characteristic</p>

	Specifications	Supplemental Information
100 kHz to 3.0 GHz (ac coupled)		
20 to 30 °C	±0.5 dB	
0 to 55 °C	±1.0 dB	
800 MHz to 1.0 GHz (ac coupled)		
20 to 30 °C	±0.5 dB	
0 to 55 °C	±1.0 dB	
1.7 GHz to 2.0 GHz (ac coupled)		
20 to 30 °C	±0.5 dB	
0 to 55 °C	±1.0 dB	
Preamp On (<i>Option 1DS</i>)		
0 dB attenuation		
1 MHz to 3.0 GHz		
20 to 30 °C	±1.5 dB	
0 to 55 °C	±2.0 dB	
800 MHz to 1.0 GHz		
20 to 30 °C	±1.5 dB	±0.22 dB, typical
0 to 55 °C	±2.0 dB	
1.7 GHz to 2.0 GHz		
20 to 30 °C	±1.5 dB	±0.16 dB, typical
0 to 55 °C	±2.0 dB	

- a. Frequency response values are referenced to the amplitude at 50 MHz.
- b. This specification applies only to analyzers with serial numbers ≥ US39441006.

	Specifications	Supplemental Information
Input Attenuation Switching Uncertainty at 50 MHz		
Attenuator Setting		
0 dB to 5 dB	±0.3 dB	
10 dB	Reference	
15 dB	±0.3 dB	
20 to 65 dB attenuation	±(0.1 dB + 0.01 × Attenuator Setting)	

Attenuation Accuracy Relative to the 10 dB Attenuator Setting, Characteristic		
	Frequency Range	
Attenuation	dc–3.0 GHz	
0 dB	±0.3 dB	
5 dB	±0.3 dB	
10 dB	Reference	
15 dB	±0.4 dB	
20 dB	±0.4 dB	
25 dB	±0.5 dB	
30 dB	±0.5 dB	
35 dB	±0.6 dB	
40 dB	±0.6 dB	
45 dB	±0.7 dB	
50 dB	±0.7 dB	
55 dB	±0.9 dB	
60 dB	±0.9 dB	
65 dB	±1.0 dB	

	Specifications	Supplemental Information
Preamp (Option 1DS)		Refer also to Displayed Average Noise Level specification
Gain		+20 dB, nominal ^a
Noise figure		5 dB, characteristic

a. Amplifier is between the input attenuator and the input mixer.

	Specifications	Supplemental Information
Absolute Amplitude Accuracy		
At reference settings ^a	±0.34 dB	±0.13 dB, typical
Preamp On ^b (Option 1DS)	±0.37 dB	±0.14 dB, typical
Overall Amplitude Accuracy^c		
20 to 30 °C	± (0.54 dB + Absolute Frequency Response)	

- a. Settings are: reference level –20 dBm; input attenuation 10 dB; dc coupled (Option UKB); center frequency 50 MHz; RBW 1 kHz; VBW 1 kHz; scale linear or log; span 2 kHz; sweep time coupled, sample detector, signal at reference level.
- b. Settings are: reference level –30 dBm; input attenuation 0 dB; dc coupled (Option UKB); center frequency 50 MHz; RBW 1 kHz; VBW 1 kHz; scale linear or log; span 2 kHz; sweep time coupled, signal at reference level.
- c. For reference level 0 to –50 dBm; input attenuation 10 dB; dc coupled (Option UKB); RBW 1 kHz; VBW 1 kHz; scale log, log range 0 to –50 dB from reference level; sweep time coupled; signal input 0 to –50 dBm; span ≤20 kHz.

	Specifications	Supplemental Information
RF Input VSWR (at tuned frequency)		
Attenuator setting 0 dB		characteristic
100 kHz to 3 GHz		≤3.0:1
Attenuator setting 5 dB		
100 kHz to 3 GHz		≤1.6:1
Attenuator setting 10 to 65 dB		
9 kHz to 100 kHz		≤2.0:1
100 kHz to 3 GHz		≤1.4:1

	Specifications	Supplemental Information		
<i>(Option UKB)</i>	Attenuator setting 0 dB		characteristic	characteristic
	100 Hz to 100 kHz		(dc coupled)	(ac coupled)
	100 kHz to 3 GHz		≤1.1:1	
	Attenuator setting 5 dB		≤3.0:1	≤3.0:1
	100 Hz to 100 kHz		(dc coupled)	(ac coupled)
	100 kHz to 300 kHz		≤1.1:1	
	300 kHz to 1.0 MHz		≤1.1:1	≤2.3:1
	1.0 MHz to 3.0 GHz		≤1.1:1	≤1.6:1
	Attenuator setting 10 to 65 dB		≤1.4:1	≤1.4:1
	100 Hz to 100 kHz		(dc coupled)	(ac coupled)
	100 kHz to 300 kHz		≤1.1:1	
	300 kHz to 1.0 MHz		≤1.1:1	≤2.1:1
1.0 MHz to 3.0 GHz		≤1.1:1	≤1.5:1	
		≤1.2:1	≤1.2:1	

	Specifications	Supplemental Information
Auto Alignment^a		
Sweep-to-sweep variation		±0.1 dB, characteristic

a. Set **Auto Align** to **Off** and use **Align Now, All** to eliminate this variation.

	Specifications	Supplemental Information
Resolution Bandwidth Switching Uncertainty (at Reference Level)		
1 kHz RBW	Reference	
3 kHz to 3 MHz RBW	±0.3 dB	
5 MHz RBW	±0.6 dB	
10 Hz to 300 Hz RBW <i>(Option 1DR)</i>	±0.3 dB	

	Specifications	Supplemental Information
Reference Level		
Range	-149.9 dBm to maximum mixer level + attenuator setting	
Resolution		
Log Scale	±0.1 dB	
Linear Scale	±0.12% of Reference Level	
Accuracy (at a fixed frequency, a fixed attenuator, and referenced to -30 dBm (-10 dBm, Preamp On (<i>Option 1DS</i>)))		
Reference Level (dBm) – input attenuator setting (dB) + preamp gain (dB)		
-10 dBm to > -60 dBm	±0.3 dB	
-60 dBm to > -85 dBm	±0.5 dB	
-85 dBm to -90 dBm	±0.7 dB	

	Specifications	Supplemental Information
Display Scale Switching Uncertainty		
Switching between Linear and Log	±0.15 dB at reference level	
Log Scale Switching	No error	

	Specifications	Supplemental Information
Display Scale Fidelity		
Log Maximum Cumulative		
RBW ≥ 1 kHz		
dB Below Reference Level		
0 dB Reference	0 dB	
> 0 to 10 dB	±0.22 dB	±0.08 dB, typical
> 10 to 20 dB	±0.24 dB	±0.09 dB, typical
> 20 to 30 dB	±0.26 dB	±0.10 dB, typical
> 30 to 40 dB	±0.40 dB	±0.23 dB, typical

	Specifications	Supplemental Information
> 40 to 50 dB	±0.57 dB	±0.35 dB, typical
> 50 to 60 dB	±0.57 dB	±0.35 dB, typical
> 60 to 70 dB	±0.66 dB	±0.39 dB, typical
>70 to 80 dB	±0.66 dB	±0.46 dB, typical
>80 to 85 dB	±1.15 dB	±0.79 dB, typical
RBW ≤ 300 Hz (<i>Option IDR</i>)		
Span > 0 Hz		
Auto range On		
0 to 98 dB below reference level	±(0.3 dB + 0.01 × dB from reference level)	±2.0 dB, characteristic
> 98 to 120 dB below reference level		
Auto range Off		
0 to 60 dB below reference level	±(0.3 dB + 0.015 × dB from reference level)	
> 60 to 70 dB below reference level	±1.5 dB	
Span = 0 Hz ^a		
0 to 60 dB below reference level	±(0.3 dB + 0.015 × dB from reference level)	
> 60 to 70 dB below reference level	±1.5 dB	
Log Incremental Accuracy		
0 to 80 dB ^b below reference level	±0.4 dB/4 dB	
Linear Accuracy		
	±2% of Reference Level	

- a. The SCPI command for auto range off is:
(:DISPlay:WINDow:TRACe:Y[:SCALe]:LOG:RANGe:AUTO OFF)
- b. 0 to -50 dB for RBWs ≤ 300 Hz and span = 0 Hz, or when auto ranging is off.

	Specifications	Supplemental Information
Spurious Responses		
Second Harmonic Distortion		
Input Signal		
10 MHz to 500 MHz	< -65 dBc for -30 dBm signal at input mixer ^a	+35 dBm SHI (second harmonic intercept)
500 MHz to 1.5 GHz	< -75 dBc for -30 dBm signal at input mixer ^a	+45 dBm SHI
Preamp On (<i>Option 1DS</i>) 10 MHz to 1.5 GHz		-5 dBm SHI, characteristic
Third Order Intermodulation Distortion		
10 MHz to 100 MHz		+7 dBm TOI (third order intercept), characteristic
100 MHz to 3 GHz	< -85 dBc for two -30 dBm signals at input mixer ^a and >50 kHz separation	+12.5 dBm TOI +16 dBm TOI, typical
Preamp On (<i>Option 1DS</i>) 10 MHz to 3 GHz		-16 dBm TOI, characteristic
Other Input Related Spurious		
>30 kHz offset	< -65 dBc for -20 dBm signal at input mixer ^a	
Out-of-band Responses	< -80 dBc for -10 dBm signal at input mixer ^a	

a. Mixer power level (dBm) = input power (dBm) – input attenuation (dB).

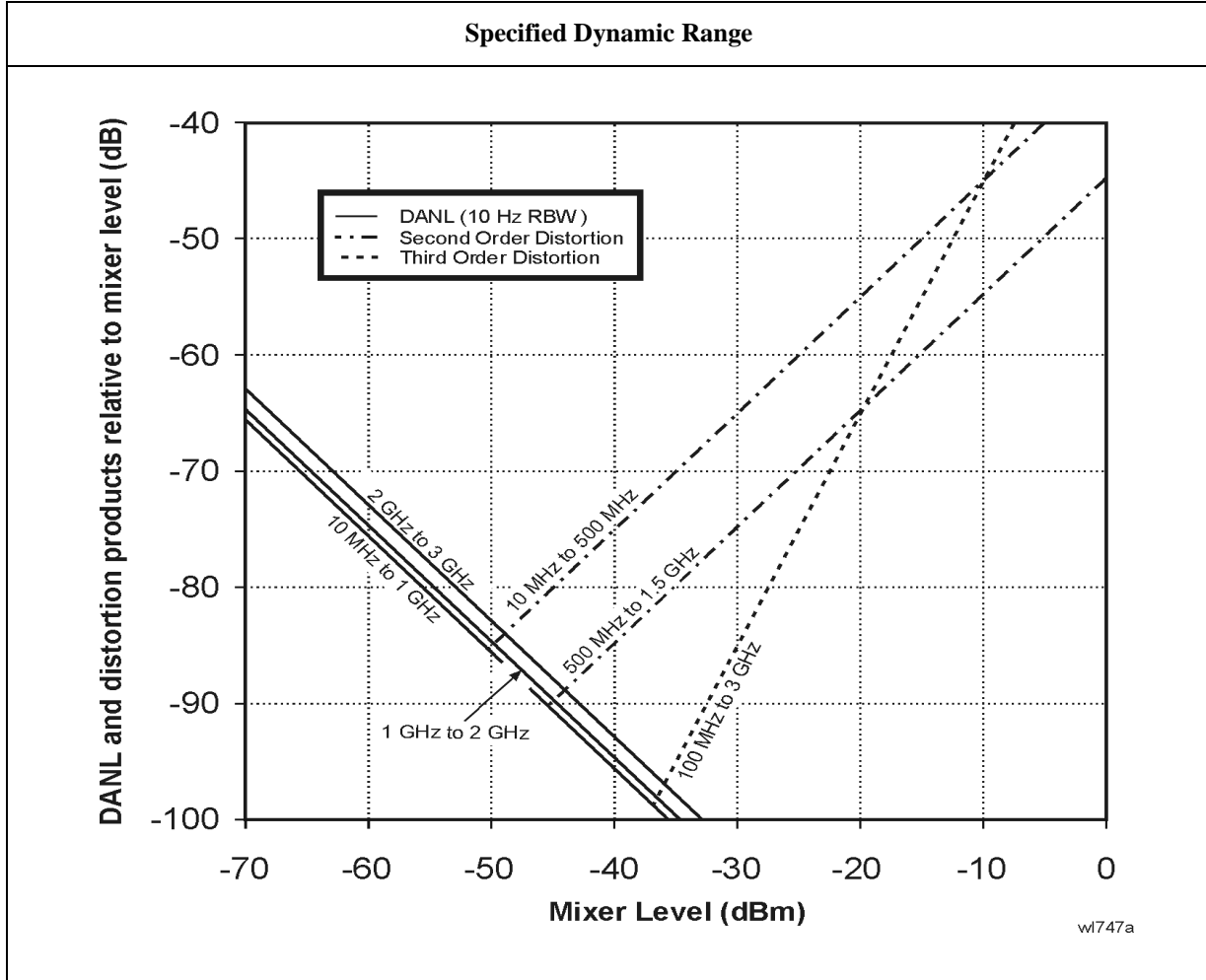

	Specifications	Supplemental Information
Residual Responses (Input terminated and 0 dB attenuation) 150 kHz to 3 GHz	< -90 dBm	

Options

Time Gated Spectrum Analysis (Option 1D6)

	Specifications	Supplemental Information
Gate Delay		
Range	1 μ s to 400 s	
Accuracy	$\pm(500 \text{ ns} + (0.01\% \times (\text{maximum of gate delay or length})))$	From gate trigger input to positive edge of gate output
Gate Length		
Range	1 μ s to 400 s	
Accuracy	$\pm(500 \text{ ns} + (0.01\% \times (\text{maximum of gate delay or length})))$	From positive edge to negative edge of gate output
Resolution	$((\text{maximum of gate delay or length in seconds})/65000)$ rounded up to nearest μ s	Dependent on the greater of gate delay or gate length
Additional Amplitude Error^a		
Log Scale	± 0.2 dB	
Linear Scale	$\pm 0.1\%$ of reference level	

a. While in gate mode.

Tracking Generator (Option 1DN)

The spectrum analyzer/tracking generator combination will meet its specification after a cable (8120-5148) and adapter are connected between RF OUT and INPUT and **Align Now, TG** has been run.

	Specifications	Supplemental Information
Warm-up	5 minutes	

	Specifications	Supplemental Information
Output Frequency Range	9 kHz to 3.0 GHz	

	Specifications	Supplemental Information
Minimum Resolution BW	1 kHz	Not usable with resolution bandwidths ≤ 300 Hz (<i>Option 1DR</i>)

	Specifications	Supplemental Information
Output Power Level		
Range	-2 to -66 dBm	
Resolution	0.1 dB	
Absolute Accuracy (at 50 MHz with coupled source attenuator, referenced to -20 dBm)	± 0.75 dB	
Vernier		
Range	8 dB	
Accuracy (with coupled source attenuator, 50 MHz, -20 dBm)		
Incremental	± 0.2 dB/dB	
Cumulative	± 0.5 dB, total	
Output Attenuator Range	0 to 56 dB in 8 dB steps	

	Specifications	Supplemental Information
Maximum Safe Reverse Level		+30 dBm (1 W), 50 Vdc, characteristic

	Specifications	Supplemental Information
Output Power Sweep		
Range	(-10 to -2 dBm) – (Source Attenuator Setting)	
Resolution	0.1 dB	
Accuracy (zero span)	<1 dB peak-to-peak	

	Specifications	Supplemental Information
Output Flatness		
Referenced to 50 MHz, -20 dBm		
9 kHz to 10 MHz	±3 dB	
10 MHz to 3 GHz	±2 dB	

	Specifications	Supplemental Information
Spurious Outputs		
(-2 dBm output)		
Harmonic Spurs		
TG Output 9 kHz to 20 kHz	≤ -15 dBc	
TG Output 20 kHz to 3 GHz	≤ -25 dBc	
Non-harmonic Spurs		
TG Output 9 kHz to 2 GHz	≤ -27 dBc	
TG Output 2 GHz to 3 GHz	≤ -23 dBc	
LO Feedthrough		
LO Frequency 3.921409 GHz to 6.9214 GHz	≤ -16 dBm	

	Specifications	Supplemental Information
Dynamic Range	Maximum Output Power Level – Displayed Average Noise Level	

	Specifications	Supplemental Information
Output Tracking Drift Swept Tracking Error		1.5 kHz/5 minute, characteristic Usable in 1 kHz RBW after 5 minutes of warm-up

	Specifications	Supplemental Information
RF Power-Off Residuals 9 kHz to 3 GHz		< -120 dBm, characteristic

	Specifications	Supplemental Information
Output Attenuator Repeatability 9 kHz to 300 MHz 300 MHz to 2 GHz 2 GHz to 3 GHz		±0.1 dB, characteristic ±0.2 dB, characteristic ±0.3 dB, characteristic

	Specifications	Supplemental Information
Output VSWR 0 dB attenuation ≥ 8 dB attenuation		<2.0:1, characteristic <1.5:1, characteristic

	Specifications	Supplemental Information
Output Attenuator Accuracy 0 dB 8 dB 16 dB 24 dB 32 dB 40 dB 48 dB 56 dB	Reference	±0.5 dB, characteristic ±0.5 dB, characteristic ±0.5 dB, characteristic ±0.6 dB, characteristic ±0.8 dB, characteristic ±1.0 dB, characteristic ±1.1 dB, characteristic

Tracking Generator Output Accuracy
Relative Accuracy (Referred to -20 dBm) = Output Attenuator Accuracy + Vernier Accuracy + Output Flatness
Absolute Accuracy = Relative Accuracy (Referred to -20 dBm) + Absolute Accuracy at 50 MHz

Bluetooth FM Demodulation (Option 106)

The FM demodulation characteristics will apply after an Align Now, FM Demod has been run.

	Specifications	Supplemental Information
Optimum Input Level		$\geq (-40 \text{ dBm} + \text{attenuator setting} - \text{preamp gain})$ and within 10 dB of the reference level
FM Deviation		
Range		$\pm 200 \text{ kHz}$, nominal
Resolution		Provides 400 Hz display annotation resolution, nominal
Accuracy ^a		
Input level = -30 dBm		$\pm 10 \text{ kHz}$, typical
Reference level = -30 dBm		$\pm 4 \text{ kHz}$ with video averaging On and averages ≥ 25
FM Rate = 500 kHz sine		
VBW = 3 MHz,		
RBW = 5 MHz,		
FM Deviation = 140 kHz		
Offset Error ^a		$\pm 1 \text{ kHz}$, typical
FM Bandwidth (-3 dB)		1.2 MHz, nominal

a. In time domain sweeps (span = 0 Hz).

Bluetooth Measurements Personality (Option 228)

The demodulation related nominals will apply after an Align Now, FM Demod has been run.

	Specifications	Supplemental Information
In-Band Frequency Range		
Bluetooth (ISM) Band	2400 to 2483.5 MHz	

	Specifications	Supplemental Information
Output Power (Option AYX or B7D)		
Range at RF Input	30 to -40 dBm	
(Option IDS)	30 to -60 dBm	
Absolute Amplitude Accuracy		See, "Absolute Amplitude Accuracy," on page 59.
Average type	Video, Power	
Average mode	Exponential, Repeat	
Trigger source	Video, RF burst ^a , External, Free Run	
Burst synch	RF Amplitude, Preamble ^b , None	

a. Requires Option B7E

b. Requires Option 106 Bluetooth FM demodulation.

	Specifications	Supplemental Information
Modulation Characteristics^a (Option 106 and AYX or B7D)		
Range at RF Input	30 to -40 dBm	
(Option IDS)	30 to -60 dBm	
FM Deviation		
Range		±200 kHz, nominal
Accuracy		±4 kHz, nominal (25 measurement averages, signal level > -30 dBm)
Payload data	11110000, 10101010, auto-detect	
Average mode	Exponential, Repeat	

	Specifications	Supplemental Information
Trigger source	Video, RF burst ^b , External, Free Run	
Burst synch	RF Amplitude, Preamble ^c , None	
Limits	$\Delta f_2/\Delta f_1$ lower, Δf_1 max lower/upper Δf_2	

- a. The DUT must have frequency hopping disabled.
- b. Requires Option B7E
- c. Requires Option 106 Bluetooth FM demodulation.

	Specifications	Supplemental Information
Carrier Frequency Drift ^a (Option 106 and AYZ or B7D)		
Range at RF Input	30 to -40 dBm	
(Option 1DS)	30 to -60 dBm	
Measurement range		±100 kHz, nominal
Measurement accuracy		±4 kHz, nominal (25 measurement averages, signal level > -30 dBm)
Average mode	Exponential, Repeat	
Trigger source	Video, RF burst ^b , External, Free Run	
Burst synch	Preamble ^c , None	

- a. The DUT must have frequency hopping disabled.
- b. Requires Option B7E
- c. Requires Option 106 Bluetooth FM demodulation.

	Specifications	Supplemental Information
Initial Carrier Frequency Tolerance (ICTF) ^a (Option 106 and AYZ or B7D)		
Range at RF Input	30 to -40 dBm	
(Option 1DS)	30 to -60 dBm	
Measurement range		±100 kHz, nominal
Measurement accuracy		±4 kHz, nominal (25 measurement averages, signal level > -30 dBm)

	Specifications	Supplemental Information
Average mode	Exponential, Repeat	
Trigger source	Video, RF burst ^b , External, Free Run	
Burst synch	RF Amplitude, Preamble ^c , None	
Limits	ICFT upper/lower	

- a. The DUT must have frequency hopping disabled.
- b. Requires Option B7E
- c. Requires Option 106 Bluetooth FM demodulation.

FM Demodulation (Option BAA)

The FM demodulation characteristics will apply after an **Align Now, FM Demod** has been run.

	Specifications	Supplemental Information
Optimum Input Level		$\geq (-60 \text{ dBm} + \text{attenuator setting} - \text{preamp gain})$ and within 30 dB of the reference level
FM Deviation		
Range		10 kHz to 1 MHz
Resolution		Provides 1 Hz display annotation resolution
FM Deviation Range		
10 kHz to 40 kHz		12 Hz, characteristic
>40 kHz to 200 kHz		60 Hz, characteristic
>200 kHz to 1 MHz		300 Hz, characteristic
Accuracy ^a		
FM Rate < FM BW/100, VBW $\geq (30 \times \text{FM Rate})$, RBW > the maximum of (30 \times FM deviation) or (30 \times FM Rate)		< (2% of FM deviation range + 2 \times Resolution), characteristic
Offset Error ^a		5% of FM Deviation Range + 300 Hz, characteristic
FM Bandwidth (-3 dB)		
FM Deviation Range		
10 kHz to 40 kHz		7.5 \times FM deviation range, characteristic
>40 kHz to 200 kHz		1.3 \times FM deviation range, characteristic
>200 kHz to 1 MHz		0.3 \times FM deviation range, characteristic

a. In time domain sweeps (span = 0 Hz).

TV Trigger and Picture On Screen (Option B7B)

Option BAA is required.

	Specifications	Supplemental Information
TV Trigger and Picture On Screen		TV Trigger initiates a sweep of the analyzer after the sync pulse of a selected line of a TV video field. Picture On Screen displays the TV picture on the analyzer display.
Amplitude Requirements TV Source: SA		Top 50% of linear display, characteristic
TV Source: EXT VIDEO IN		500 mVp-p to 2 Vp-p, characteristic
Compatible Standards	NTSC-M, NTSC-Japan, PAL-M, PAL-B,D,G,H,I, PAL-N, PAL-N Combination, SECAM-L	
Field Selection	Entire frame, even, odd	
Sync Polarity	Positive or negative	
TV Trigger		
Line Selection	1 to 525, or 1 to 625, standard dependent	

cdmaOne Measurement Personality (Option BAC)

Unless otherwise noted, all specifications are with RF input range auto, default cdmaOne measurement settings, and in the in-band frequency range. *Option B72* is required.

	Specifications	Supplemental Information
In-Band Frequency Range		
Cellular bands	824 to 870 MHz 869 to 925 MHz	
PCS bands	1715 to 1780 MHz 1805 to 1870 MHz 1850 to 1910 MHz 1930 to 1990 MHz	

	Specifications	Supplemental Information
Adjacent Channel Power Ratio^a		
Carrier power range at RF Input	30 to -20 dBm	
Dynamic range ^b		Referenced to average power of carrier in 1.23 MHz BW
Offset Frequency	Integration BW	
750 kHz	30 kHz	-70.0 dBc, characteristic
885 kHz	30 kHz	-73.5 dBc, characteristic
1.25625 MHz	12.5 kHz	-78.0 dBc, characteristic
1.98 MHz	30 kHz	-75.5 dBc, characteristic
2.75 MHz	1 MHz	-60.5 dBc, characteristic
Relative accuracy ^c	See Display Scale Fidelity	
Resolution	0.01 dB	

- This measurement is available with personality revisions of A.02.00 or later.
- IS-97A nominal base station test model levels (fraction of carrier power); Pilot: 0.20 (-7.0 dBc), Sync: 0.0471 (-13.3 dBc), Paging: 0.1882 (-7.3 dBc), 6 Traffic channels: 0.09412 (-10.3 dBc)
- Does not include uncertainty due to noise.

	Specifications	Supplemental Information
Channel Power (1.23 MHz Integration BW)		Integration BW range 1 kHz to 10 MHz
Range at RF Input	30 to -70 dBm	
Absolute power accuracy for in-band signal (Mean channel power at RF Input, plus any external attenuation, excluding mismatch error)		
Cellular Bands		
30 to -5 dBm 20 to 30 °C	±0.78 dB	±0.33 dB, typical
0 to 55 °C	±1.21 dB	
-5 to -25 dBm 20 to 30 °C	±0.72 dB	±0.28 dB, typical
0 to 55 °C	±1.05 dB	
-25 to -45 dBm 20 to 30 °C	±0.63 dB	±0.22 dB, typical
0 to 55 °C	±0.91 dB	
-45 to -55 dBm 20 to 30 °C	±0.70 dB	±0.29 dB, typical
0 to 55 °C	±0.92 dB	
-55 to -70 dBm 20 to 30 °C	±0.82 dB	±0.39 dB, typical
0 to 55 °C	±1.17 dB	
PCS Bands		
30 to -5 dBm 20 to 30 °C	±0.67 dB ^a	±0.23 dB ^a , typical
0 to 55 °C	±1.00 dB ^a	
-5 to -25 dBm 20 to 30 °C	±0.63 dB ^a	±0.21 dB ^a , typical
0 to 55 °C	±0.94 dB ^a	
-25 to -45 dBm 20 to 30 °C	±0.63 dB ^a	±0.21 dB ^a , typical
0 to 55 °C	±0.88 dB ^a	

	Specifications	Supplemental Information
-45 to -55 dBm 20 to 30 °C	±0.70 dB ^a	±0.28 dB ^a , typical
0 to 55 °C	±0.89 dB ^a	
-55 to -70 dBm 20 to 30 °C	±0.82 dB ^a	±0.38 dB ^a , typical
0 to 55 °C	±1.14 dB ^a	

a. For Option UKB, add 0.10 dB.

Channel Power (1.23 MHz Integration BW)		Integration BW range 1 kHz to 10 MHz
Range at RF Input	30 to -70 dBm	
Absolute power accuracy for in-band signal (Mean channel power at RF Input, plus any external attenuation, excluding mismatch error)		
Cellular Bands		
30 to -5 dBm 20 to 30 °C	±0.80 dB	±0.36 dB, typical
0 to 55 °C	±1.13 dB	
-5 to -25 dBm 20 to 30 °C	±0.77 dB	±0.33 dB, typical
0 to 55 °C	±1.10 dB	
-25 to -45 dBm 20 to 30 °C	±0.65 dB	±0.29 dB, typical
0 to 55 °C	±1.00 dB	
-45 to -55 dBm 20 to 30 °C	±0.72 dB	±0.36 dB, typical
0 to 55 °C	±1.01 dB	
-55 to -70 dBm 20 to 30 °C	±0.86 dB	±0.47 dB, typical
0 to 55 °C	±1.28 dB	
PCS Bands		
30 to -5 dBm 20 to 30 °C	±0.70 dB	±0.29 dB, typical

0 to 55 °C	±1.15 dB	±0.26 dB, typical
-5 to -25 dBm 20 to 30 °C	±0.67 dB	
0 to 55 °C	±1.11 dB	±0.27 dB, typical
-25 to -45 dBm 20 to 30 °C	±0.66 dB	
0 to 55 °C	±0.97 dB	±0.34 dB, typical
-45 to -55 dBm 20 to 30 °C	±0.73 dB	
0 to 55 °C	±0.98 dB	±0.45 dB, typical
-55 to -70 dBm 20 to 30 °C	±0.87 dB	
0 to 55 °C	±1.25 dB	

	Specifications	Supplemental Information
Channel power relative power accuracy (same channel, different Tx power, input attenuator fixed, RF input range manual).	See Display Scale Fidelity	

	Specifications	Supplemental Information
Receive Channel Power		
Absolute Power Accuracy		
Cellular bands		
30 to 0 dBm	±1.07 dB	±0.62 dB, typical
0 to -85 dBm	±1.64 dB	±0.89 dB, typical
PCS bands		
30 to 0 dB	±0.86 dB ^a	±0.42 dB ^a , typical
0 to -85 dBm	±1.76 dB ^a	±0.94 dB ^a , typical
Preamp (<i>Option IDS</i>)		
Cellular bands		
30 to -80 dBm	±2.96 dB	±2.40 dB, typical
-80 to -100 dBm	±4.07 dB	±3.23 dB, typical
PCS bands		
30 to -80 dB	±2.14 dB	±1.45 dB, typical
-80 to -100 dBm	±3.37 dB	±2.40 dB, typical

a. For Option UKB, add 0.10 dB.

	Specifications	Supplemental Information
Receive Channel Power		
Absolute Power Accuracy		
Cellular bands		
30 to 0 dBm	±0.98 dB	±0.55 dB, typical
0 to -85 dBm	±2.02 dB	±1.33 dB, typical
PCS bands		
30 to 0 dB	±1.00 dB	±0.60 dB, typical
0 to -85 dBm	±1.52 dB	±0.84 dB, typical
Preamp (<i>Option 1DS</i>)		
Cellular and PCS bands		
30 to -80 dBm	±2.45 dB	±1.70 dB, typical
-80 to -100 dBm	±3.20 dB	±2.30 dB, typical

	Specifications	Supplemental Information
Occupied Bandwidth		
Carrier power range	30 to -45 dBm	
Frequency resolution of occupied BW	1.88 kHz	
Frequency accuracy of occupied BW (1.23 MHz channel BW)		±15 kHz, characteristic
Frequency resolution of delta frequency	3.75 kHz	
Frequency accuracy of delta frequency		± (35 kHz + frequency reference error × carrier frequency), characteristic

	Specifications	Supplemental Information
Code Domain Power (Requires <i>Options 1D5, B7D, and B7E</i> . Measurement interval ≥1.25 ms unless otherwise noted.)		
Carrier power range at RF Input (Pilot channel power > -11 dBc)	30 to -13 dBm	30 to -65 dBm ^a , characteristic
Preamp (<i>Option 1DS</i>)	30 to -30 dBm	30 to -82 dBm ^a , characteristic
Measurement interval range	0.5 ms to 26.67 ms	

	Specifications	Supplemental Information
Code domain power		
Display dynamic range	50 dB	
Accuracy (Walsh channel power within 20 dB of total power)		±0.2 dB, typical
Displayed resolution	0.01 dB	
Other reported power parameters (dB referenced to total power)		Average active traffic, maximum inactive traffic, average inactive traffic, pilot, paging, sync channels
Carrier frequency error (Measurement interval ≥2.5 ms)		Excludes frequency reference error.
Input frequency error range	±100 kHz	±200 kHz, typical
Accuracy	±10 Hz	±7 Hz, typical
Displayed resolution	Four digits	
Estimated Rho		
Range	0.9 to 1.0	0.5 to 1.0 ^b
Accuracy (With 9 channels active over the specified range) ^c		±0.02, characteristic
Displayed resolution	0.0001	
Pilot time offset		From even second signal to start of PN sequence
Range	-13.33 ms to +13.33 ms	
Accuracy	±150 ns	
Displayed resolution	Four digits	
Code domain timing		Pilot to code channel time tolerance
Range	±200 ns	
Accuracy (IS-97A nominal power levels) ^d		±7 ns, typical
Code domain phase		Pilot to code channel phase tolerance
Range	±200 mrad	
Accuracy (IS-97A nominal power levels) ^d		±10 mrad, typical

	Specifications	Supplemental Information
Displays		Power Graph and Metrics, or Power, Timing, and Phase Graphs

- a. Performance may degrade outside of the specified carrier power range at RF input listed in the specifications column.
- b. Performance may degrade outside of the estimated rho range listed in the specifications column.
- c. The Active Set Threshold is less than all active channels, but greater than -20 dBc.
- d. IS-97A nominal base station test model levels (fraction of carrier power); Pilot: 0.20 (-7.0 dBc), Sync: 0.0471 (-13.3 dBc), Paging: 0.1882 (-7.3 dBc), 6 Traffic channels: 0.09412 (-10.3 dBc)

	Specifications	Supplemental Information
Modulation Accuracy (Rho) (Requires <i>Options 1D5, B7D,</i> and <i>B7E</i> . Measurement interval ≥1.25 ms unless otherwise noted.)		
Carrier power range at RF Input	30 to -28 dBm	30 to -70 dBm ^a , characteristic
Preamp (<i>Option 1DS</i>)	30 to -45 dBm	30 to -87 dBm ^a , characteristic
Measurement interval range	0.15 ms to 26.67 ms	
Rho (waveform quality)		
Range	0.9 to 1.0	0.5 to 1.0 ^b , characteristic
Accuracy		±0.0016, typical
Displayed resolution	0.0001	
Carrier frequency error (Measurement interval ≥2.5 ms)		Excludes frequency reference error
Input frequency error range	±100 kHz	±200 kHz, typical
Accuracy	±10 Hz	±7 Hz, typical
Displayed resolution	Four digits	
Pilot time offset		From even second signal to start of PN sequence
Range	-13.33 ms to +13.33 ms	
Accuracy	±150 ns	
Displayed resolution	Four digits	
EVM		
Floor		3.8%, typical
Accuracy ^c		±1.1%, typical
Displayed Resolution	0.01%	

	Specifications	Supplemental Information
Carrier feedthrough		
Floor		-51 dBc, typical
Accuracy (Carrier feedthrough ≥ -43 dBc)		±2.3 dB, typical
Displayed resolution	0.01 dB	
Magnitude error		
Floor		3.8%, typical
Accuracy ^c		±1.1%, typical
Displayed resolution	0.01%	
Phase error		
Accuracy ^c		±0.65 degrees, typical
Displayed resolution	0.01 degrees	
Displays		Numeric results or Numeric results and IQ graph

- a. Performance may degrade outside of the specified carrier power range at RF input listed in the specifications column.
- b. Performance may degrade outside of the rho range listed in the specifications column.
- c. Accuracy does not include the effects of the EVM floor. The measurement variance increases as the result approaches the EVM floor.

	Specifications	Supplemental Information
Spur Close (In Band)		
Carrier power range at RF Input	30 to -12 dBm	
Dynamic range		
Input power		
30 to 25 dBm	55 dB	
25 to 20 dBm	50 dB	
20 to -12 dBm	46 dB	
Relative accuracy	±(2.7 dB + 0.01 × (dB from reference level))	±(0.3 dB + 0.01 × (dB from reference level)), typical
Displayed resolution	0.01 dB	

	Specifications	Supplemental Information
Out-of-Band Spurious^a		Refer to the Amplitude specifications section in this guide.

- a. The out-of-band measurement is made with the user-defined tables with 20 frequency ranges each (up to the top 10 spurs per range, 100 spurs maximum). Table parameters include frequency range, RBW, video BW, detector type, and amplitude test limits.

	Specifications	Supplemental Information
Receiver Spurious Emissions		
Spurious emission power range	-20 to -83 dBm	
Preamp On (<i>Option IDS</i>)	-40 to -101 dBm	
Absolute spurious emission power accuracy		
-20 to -60 dBm	±2.6 dB ^a	±1.7 dB ^a , typical
-60 to -83 dBm	±4.3 dB ^a	±3.4 dB ^a , typical
Preamp On (<i>Option IDS</i>)		
-40 to -70 dBm	±3.6 dB	±2.6 dB, typical
-70 to -101 dBm	±5.0 dB	±3.9 dB, typical

- a. For Option UKB, add 0.10 dB.

	Specifications	Supplemental Information
External Correction		
External attenuation, external gain		
Range	-90 to 90 dB	
Resolution	0.01 dB	

	Specifications	Supplemental Information
Trigger		
Trigger source (Actual available choices dependent on measurement)	Free run, external	
(<i>Option B7D and B7E</i>)	Add RF Burst, frame	
Delay trigger		
Range	0 to 500 ms	
Resolution	300 ns	

	Specifications	Supplemental Information
RF burst trigger level (<i>Option B7E</i>)	0 to -25 dBc	Rear panel connector labelled EXT FRAME SYNC (<i>Option B7D</i>)
Trigger slope (External and RF burst)	Positive/Negative	
Frame timing period	50 ns to 13.6533 s	
Frame synchronizing source	External frame sync	
Frame synchronizing slope	Positive/Negative	

	Specifications	Supplemental Information
Demod Trigger Source		
Even second input (Frame trigger only, <i>Option B7D</i> and <i>B7E</i>)		Rear panel connector labelled EXT FRAME SYNC
PN offset range	0 to 511 x 64 [chips]	

GSM Measurement Personality (Option BAH)

Unless otherwise noted, all specifications are with RF input range auto, default GSM measurement settings, and in the in-band frequency range. *Option 1D6* and *Option B72* are required.

	Specifications	Supplemental Information
In-Band Frequency Range		
GSM 900, P-GSM bands	890 to 915 MHz 935 to 960 MHz	
GSM 900, E-GSM bands	880 to 915 MHz 925 to 960 MHz	
GSM 900, R-GSM bands	876 to 915 MHz 921 to 960 MHz	
DCS 1800 bands	1710 to 1785 MHz 1805 to 1880 MHz	
PCS 1900 bands	1850 to 1910 MHz 1930 to 1990 MHz	

	Specifications	Supplemental Information
Transmitter Power (Requires <i>Option B7D</i> or <i>AYX</i>)		
Range at RF Input	30 to -60 dBm	
Absolute power accuracy for in-band signal (Mean channel power at RF Input, plus any external attenuation, excluding mismatch error)		
P-GSM, E-GSM, and R-GSM Bands		
30 to -20 dBm 20 to 30 °C	±0.89 dB	±0.39 dB, typical
0 to 55 °C	±1.65 dB	
-20 to -30 dBm 20 to 30 °C	±0.82 dB	±0.38 dB, typical
0 to 55 °C	±1.48 dB	

	Specifications	Supplemental Information
-30 to -40 dBm 20 to 30 °C	±0.87 dB	±0.39 dB, typical
0 to 55 °C	±1.47 dB	
-40 to -50 dBm 20 to 30 °C	±1.06 dB	±0.57 dB, typical
0 to 55 °C	±1.60 dB	
-50 to -60 dBm 20 to 30 °C	±1.19 dB	±0.70 dB, typical
0 to 55 °C	±1.71 dB	
DCS 1800 and PCS 1900 Bands		
30 to -20 dBm 20 to 30 °C	±0.76 dB ^a	±0.28 dB ^a , typical
0 to 55 °C	±1.26 dB ^a	
-20 to -30 dBm 20 to 30 °C	±0.66 dB ^a	±0.27 dB ^a , typical
0 to 55 °C	±1.06 dB ^a	
-30 to -40 dBm 20 to 30 °C	±0.71 dB ^a	±0.26 dB ^a , typical
0 to 55 °C	±1.00 dB ^a	
-40 to -50 dBm 20 to 30 °C	±0.90 dB ^a	±0.44 dB ^a , typical
0 to 55 °C	±1.13 dB ^a	
-50 to -60 dBm 20 to 30 °C	±1.03 dB ^a	±0.57 dB ^a , typical
0 to 55 °C	±1.24 dB ^a	

a. For Option UKB, add 0.10 dB.

	Specifications	Supplemental Information
Transmitter Power (Requires <i>Option B7D</i> or <i>AYX</i>)		
Range at RF Input	30 to -60 dBm	

	Specifications	Supplemental Information
<p>Absolute power accuracy for in-band signal (Mean channel power at RF Input, plus any external attenuation, excluding mismatch error)</p> <p>P-GSM, E-GSM, and R-GSM Bands</p>		
<p>30 to -20 dBm 20 to 30 °C</p>	±0.81 dB	±0.38 dB, typical
<p>0 to 55 °C</p>	±1.31 dB	
<p>-20 to -30 dBm 20 to 30 °C</p>	±0.74 dB	±0.37 dB, typical
<p>0 to 55 °C</p>	±1.14 dB	
<p>-30 to -40 dBm 20 to 30 °C</p>	±0.79 dB	±0.37 dB, typical
<p>0 to 55 °C</p>	±1.11 dB	
<p>-40 to -50 dBm 20 to 30 °C</p>	±0.95 dB	±0.53 dB, typical
<p>0 to 55 °C</p>	±1.21 dB	
<p>-50 to -60 dBm 20 to 30 °C</p>	±1.09 dB	±0.66 dB, typical
<p>0 to 55 °C</p>	±1.33 dB	
<p>DCS 1800 and PCS 1900 Bands</p>		
<p>30 to -20 dBm 20 to 30 °C</p>	±0.68 dB	±0.28 dB, typical
<p>0 to 55 °C</p>	±1.30 dB	
<p>-20 to -30 dBm 20 to 30 °C</p>	±0.61 dB	±0.27 dB, typical
<p>0 to 55 °C</p>	±1.12 dB	
<p>-30 to -40 dBm 20 to 30 °C</p>	±0.66 dB	±0.27 dB, typical
<p>0 to 55 °C</p>	±0.99 dB	
<p>-40 to -50 dBm 20 to 30 °C</p>	±0.82 dB	±0.43 dB, typical
<p>0 to 55 °C</p>	±1.09 dB	

	Specifications	Supplemental Information
-50 to -60 dBm 20 to 30 °C	±0.96 dB	±0.56 dB, typical
0 to 55 °C	±1.21 dB	

	Specifications	Supplemental Information
Transmitter Power Relative Power Accuracy (same channel, different Tx power, input attenuator fixed, RF input range manual).	See Display Scale Fidelity	

	Specifications	Supplemental Information
Power versus Time (Requires <i>Option B7D</i> or <i>AYX</i>)		
Carrier power range at RF Input	30 to -23 dBm	30 to -55 dBm ^a , characteristic
Preamplifier On (<i>Option 1DS</i>)	30 to -40 dBm	30 to -72 dBm ^a , characteristic
Time resolution accuracy		±1% of sweep time, characteristic
Maximum record length	8 time slots	
Burst to mask uncertainty (Requires <i>Option B7D</i> and <i>B7E</i>)	±1.0 bit	

a. Performance may degrade outside of the specified carrier power range at RF input listed in the specifications column.

	Specifications	Supplemental Information
Output RF Spectrum		
Carrier power range at RF Input		
Offsets ≤1800 kHz, 30 kHz RBW		30 to -5 dBm, characteristic
Offsets >1800 kHz, 100 kHz RBW		30 to -4 dBm, characteristic
Reference power accuracy	Same as Transmitter Power measurement	
Relative accuracy ^a	See Display Scale Fidelity	

	Specifications	Supplemental Information
Spectrum due to modulation displayed dynamic range ^{b,c}		
100 kHz offset		30 dB, characteristic
200 kHz offset		60 dB, characteristic
250 kHz offset		60 dB, characteristic
400 kHz offset		70 dB, characteristic
600 kHz to 1.8 MHz offset		79 dB, characteristic
1.8 to 6.0 MHz offset		75 dB, characteristic
> 6 MHz offset		76 dB, characteristic
Swept Mode Dynamic Range		70 dB, characteristic
Spectrum due to switching transients displayed dynamic range ^{b,c}		
400 kHz offset		62 dB, characteristic
600 kHz offset		79 dB, characteristic
1200 kHz offset		79 dB, characteristic
1800 kHz offset		80 dB, characteristic
Swept Mode Dynamic Range		70 dB, characteristic

- a. Does not include uncertainty due to noise.
- b. Displayed dynamic range for specific frequency offsets—applies to CW signal at the specified offset. Dynamic range with a GSM signal may differ.
- c. Using default settings, the RBW filter has a corrected noise BW and impulse BW equivalent to five-pole synchronously tuned filter.

	Specifications	Supplemental Information
Phase and Frequency Error (Requires <i>Option 1D5, B7D, and B7E</i>)		
Carrier power range at RF Input	30 to -23 dBm	30 to -55 dBm ^a , characteristic
Preamplifier On (<i>Option 1DS</i>)	30 to -40 dBm	30 to -72 dBm ^a , characteristic
Phase error		
Range	0 to 180°	
Displayed resolution	0.01°	
Accuracy (Averages ≥10)		
Peak	±2.1°	±1.5°, typical

	Specifications	Supplemental Information
RMS Frequency error	$\pm 1.1^\circ$	$\pm 0.6^\circ$, typical Excludes frequency reference error
Initial frequency error range	± 100 kHz	
Accuracy (Averages ≥ 10)	± 10 Hz	± 5 Hz, typical
I/Q offset range	-10 to -46 dBc	
Burst sync time uncertainty	± 0.1 bit	
Displays		Numeric summary

- a. Performance may degrade outside of the specified carrier power range at RF input listed in the specifications column.

	Specifications	Supplemental Information
Transmit Band Spurious		
Carrier power range at RF Input		30 to -12 dBm, typical
Dynamic range		
Upper and lower adjacent segments		55 dB, characteristic
Upper and lower segments		44 dB, characteristic
Relative accuracy		$\pm(0.3 \text{ dB} + 0.01 \times (\text{dB from reference level}))$, characteristic
Displayed resolution	0.01 dB	

	Specifications	Supplemental Information
Out-of-Band Spurious^a		
Absolute Spurious Power Accuracy		Refer to the Amplitude specifications section in this guide.
Sensitivity ^b		
RBW		
1 kHz		-95 dBm, characteristic
3 kHz		-90 dBm, characteristic
10 kHz		-85 dBm, characteristic
30 kHz		-78 dBm, characteristic
100 kHz		-71 dBm, characteristic
300 kHz		-64 dBm, characteristic

	Specifications	Supplemental Information
1 MHz		-57 dBm, characteristic
3 MHz		-50 dBm, characteristic

- a. The out-of-band spurious measurement is made in accordance with the tables defined in the appropriate GSM specification document. The measurement is made over several frequency ranges (up to 10 spurs per range, 100 spurs maximum).
- b. With input attenuation of 5 dB. For all other attenuation settings, add (input attenuation - 5) dB.

	Specifications	Supplemental Information
Receive Band Spurious		
Spurious emission power range ^a		-20 to -73 dBm, characteristic
Preamp On (<i>Option IDS</i>)		-40 to -91 dBm, characteristic
Absolute spurious emission power accuracy		
-20 to -60 dBm		±1.9 dB ^b , characteristic
-60 to -73 dBm		±2.5 dB ^b , characteristic
Preamp on (<i>Option IDS</i>)		
-40 to -70 dBm		±2.8 dB, characteristic
-70 to -91 dBm		±4.1 dB, characteristic

- a. Requires bandpass filter centered on receive band, peak detector mode, 0 dB attenuation, 100 kHz RBW. Does not include insertion loss of bandpass filter.
- b. For Option UKB, add 0.10 dB.

	Specifications	Supplemental Information
Amplitude Range Control		RF Input Autorange, Manually set Max Total Pwr Manually set Input Atten

	Specifications	Supplemental Information
External Gain/Attenuation Correction		
Base gain, base attenuation, mobile gain, mobile attenuation		
Range	0 to 81.9 dB	
Resolution	0.01 dB	

	Specifications	Supplemental Information
Trigger		
Trigger source (Actual available choices dependent on measurement) (<i>Option B7D and B7E</i>)	Free run, external Add RF Burst and frame	
RF burst trigger (<i>Option B7E</i>)		
Peak carrier power range ^a	30 to -25 dBm	30 to -30 dBm, typical
Preamp On (<i>Option 1DS</i>)	30 to -45 dBm	30 to -50 dBm, typical
Trigger level range	0 to -25 dB relative to signal peak	

a. With trigger level set to -6 dB.

	Specifications	Supplemental Information
Burst Sync (Requires <i>Option AYX or B7D</i>)		
Source (Actual available choices dependent on measurement) (<i>Option B7D and B7E</i>)	RF amplitude, none Add training sequence	
Training sequence code		GSM defined 0 to 7 Auto (search) or Manual
Burst type		Normal (TCH and CCH) Sync (SCH) Access (RACH)

General

	Specifications	Supplemental Information
Temperature Range		
Operating	0 to 55 °C	Floppy disk 10 to 40 °C
Storage	-40 to 75 °C	

	Specifications	Supplemental Information
Audible Noise (ISO 7779)		
Sound Pressure at 25 °C		<40 dBa, (<4.6 Bels power)

	Specifications	Supplemental Information
Military Specification	Has been type tested to the environmental specifications of MIL-PRF-28800F class 3.	

	Specifications	Supplemental Information
EMI Compatibility	Conducted and radiated emission is in compliance with CISPR Pub. 11/1990 Group 1 Class A.	
<i>(Option 060)^a</i>	Conducted and radiated emission is in compliance with CISPR Pub. 11/1990 Group 1 Class B ^b .	

- a. Option 060 is not compatible with Option B7B nor Option 1DP.
b. Meets Class A performance during dc operation.

	Specifications	Supplemental Information
Immunity Testing		
Radiated Immunity		Testing was done at 3 V/m according to IEC 801-3/1984. When the analyzer tuned frequency is identical to the immunity test signal frequency, there may be signals of up to -60 dBm displayed on the screen.

	Specifications	Supplemental Information
Electrostatic Discharge		Air discharges of up to 8 kV were applied according to IEC 801-2/1991. Discharges to center pins of any of the connectors may cause damage to the associated circuitry.

	Specifications	Supplemental Information
Power Requirements		
ac Operation		
Voltage, frequency	90 to 132 Vrms, 47 to 440 Hz 195 to 250 Vrms, 47 to 66 Hz	
Power Consumption, On	<300 W	
Power Consumption, Standby	<5 W	
dc Operation		
Voltage	12 to 20 Vdc	
Power Consumption	<200 W	
Power Consumption, Standby	<100 mW	

	Specifications	Supplemental Information
Measurement Speed		
Local Measurement and Display Update rate ^a		
Sweep points = 101		≥ 45/s, characteristic
Sweep points = 401		≥ 30/s, characteristic
Remote Measurement and GPIB Transfer Rate ^{b,c}		
(Option A4H)		
Sweep points = 101		≥ 45/s, characteristic
Sweep points =401		≥ 30/s, characteristic

	Specifications	Supplemental Information
RF Center Frequency Tune, Measure, and GPIB Transfer Time ^{b,d} (Option A4H) Sweep points = 101 Sweep points = 401		≤ 75 ms, characteristic ≤ 90 ms, characteristic

- Factory preset, auto align Off, segmented sweep Off, fixed center frequency, RBW = 1 MHz, and spans >10 MHz and ≤600 MHz.
- Display Off (:DISPlay:ENABle OFF), and 32-bit integer data format (:FORMat:DATA INT,32), if Option AYX or A4J is installed, disable sweep ramp, (:SYSTem:PORTs:IFVSweep:ENABle OFF), markers Off, single sweep, measured with IBM compatible PC with 550 MHz Pentium® III running Windows® NT 4.0, one meter GPIB cable, National Instruments PCI-GPIB card and NI-488.2 DLL.
- Factory preset, auto align Off, segmented sweep Off, RBW = 1 MHz, span= 20 MHz, fixed center frequency, average of 100 measurements.
- Factory preset, auto align Off, segmented sweep Off, RBW = 1 MHz, span= 20 MHz, and center frequency tune step size = 50 MHz.

	Specifications	Supplemental Information
Data Storage Internal External (10 to 40 °C) 3.5" 1.44 MB, MS-DOS® compatible floppy disk		200 Traces or States ^a 200 Traces or States ^a

- When storing traces set to 401 points.

	Specifications	Supplemental Information
Downloadable Program Memory (Option B72)		2 MB available memory 10 MB available memory

	Specifications	Supplemental Information
Demod Tune and Listen Demod <i>(Option BAA or 106)</i> <i>(Option A4J or AYW)</i> <i>(Option 106 or BAA)</i>	AM Add FM	Internal speaker, front-panel earphone jack and front-panel volume control. An uncalibrated demodulated signal is available on the AUX VIDEO OUT connector at the rear panel. An uncalibrated demodulated signal is available on the EXT VIDEO OUT connector at the rear panel.

	Specifications	Supplemental Information
Weight (without options) Net Shipping		15.5 kg (34.2 lb), characteristic 27.4 kg (60.4 lb), characteristic

Dimensions

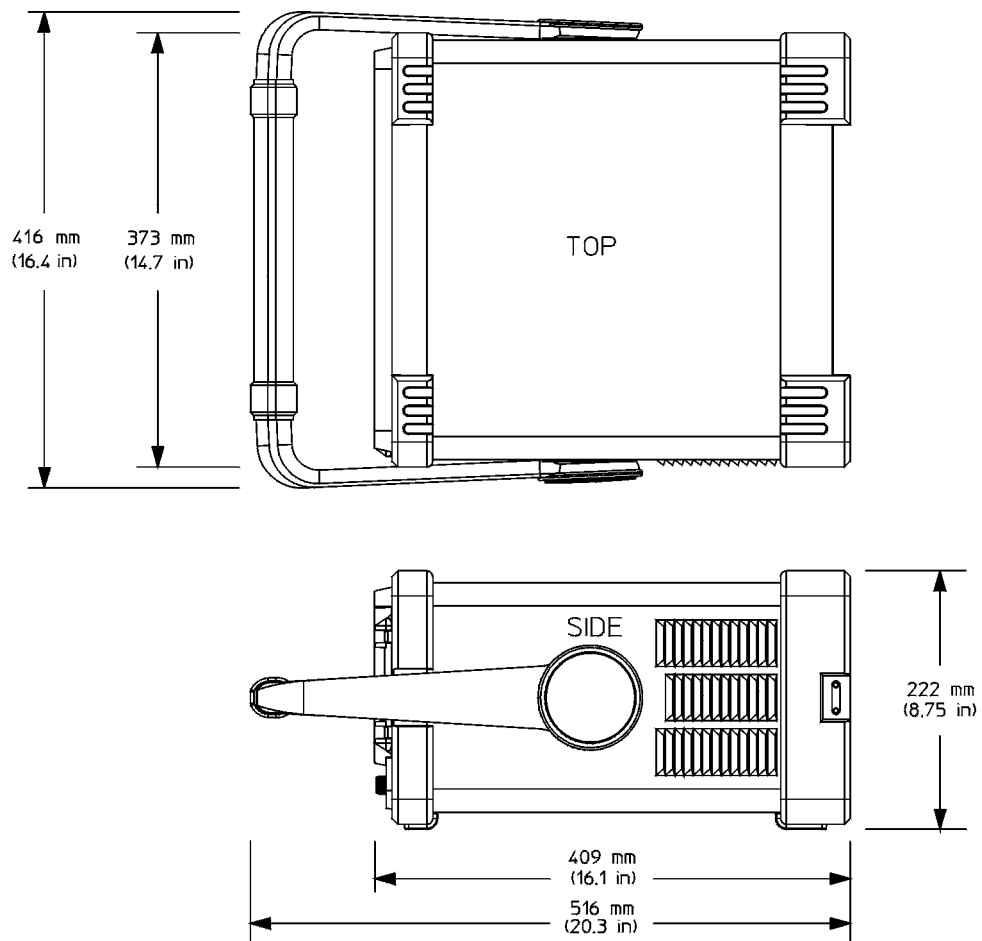

n1742a

Inputs and Outputs

Front Panel

	Specifications	Supplemental Information
INPUT 50 Ω Connector Impedance LO Emissions	Type-N female	50 Ω , nominal < -70 dBm, characteristic. Average level of 1st LO, 3.9214 to 6.9214 GHz, present at INPUT 50 Ω connector.

	Specifications	Supplemental Information
RF OUT 50 Ω, (Option 1DN) Connector Impedance	Type-N female	50 Ω , nominal

	Specifications	Supplemental Information
AMPTD REF OUT^a Connector Impedance Frequency Frequency Accuracy 50 Ω Amplitude ^c	BNC female	Amplitude Reference 50 Ω , nominal 50 MHz Frequency reference error ^b -20 dBm, nominal

- a. Turn the amplitude reference on/off by pressing the keys: **Input/Output, Amptd Ref Out.**
- b. Frequency reference error = (aging rate \times period of time since adjustment + settability + temperature stability).
- c. The internal amplitude reference actual power is stored internally.

	Specifications	Supplemental Information
PROBE POWER Voltage/Current		+15 Vdc, $\pm 7\%$ at 150 mA max., characteristic -12.6 Vdc $\pm 10\%$ at 150 mA max., characteristic

	Specifications	Supplemental Information
EXT KEYBOARD^a		Used for entering screen titles and filenames only. Interface compatible with most IBM-compatible PC keyboards.
Connector	6-pin mini-DIN	

a. The feature is not implemented in firmware revisions prior to A.04.00.

	Specifications	Supplemental Information
Speaker		Front panel knob controls volume

	Specifications	Supplemental Information
Headphone		Front panel knob controls volume
Connector	3.5 mm (1/8 inch) miniature audio jack	
Power Output		0.2 W into 4 Ω , characteristic

Rear Panel

	Specifications	Supplemental Information
10 MHz REF OUT		
Connector	BNC female	
Impedance		50 Ω , nominal
Output Amplitude		>0 dBm, characteristic

	Specifications	Supplemental Information
10 MHz REF IN		
Connector	BNC female	Note: Analyzer noise sidebands and spurious response performance may be affected by the quality of the external reference used.
Impedance		50 Ω , nominal
Input Amplitude Range		-15 to +10 dBm, characteristic
Frequency		10 MHz, nominal

	Specifications	Supplemental Information
EXT REF IN (Option B7E)		
Connector	BNC, female	
Impedance		50 Ω, nominal
Input amplitude range	-5 to 10 dBm	
Frequency	1 to 30 MHz, selectable	
Frequency lock range	$\pm 5 \times 10^{-6}$ of specified external reference input frequency	

	Specifications	Supplemental Information
10 MHz OUT (Option B7E)		
Connector	BNC, female	
Impedance		50 Ω, nominal
Frequency		10 MHz, nominal
Level		0 dBm when Option 10 MHz Out is On

	Specifications	Supplemental Information
GATE TRIG/EXT TRIG IN		
Connector	BNC female	
External Trigger Input		
Trigger Level		Selectable positive or negative edge initiates sweep in EXT TRIG mode (5 V TTL)
Gate Trigger Input (Option 1D6)		
Minimum Pulse Width		>30 ns (5 V TTL)

	Specifications	Supplemental Information
GATE/HI SWP OUT		
Connector	BNC female	
High Sweep Output		

Agilent E4402B Specifications and Characteristics
Inputs and Outputs

	Specifications	Supplemental Information
Level		High = sweep ^a ; Low = retrace (5 V TTL)
Gate Output (<i>Option 1D6</i>)		
Level		High = gate on; Low = gate off (5 V TTL)

a. High sweep may be high longer than the indicated sweep times.

	Specifications	Supplemental Information
VGA OUTPUT		
Connector	VGA compatible, 15-pin mini D-SUB	
Format		VGA (31.5 kHz horizontal, 60 Hz vertical sync rates, non-interlaced) Analog RGB
Resolution	640 × 480	

	Specifications	Supplemental Information
AUX IF OUT (<i>Option A4J or AYX</i>)		RBW ≥ 1 kHz
Connector	BNC female	
Frequency		21.4 MHz, nominal
Amplitude (for signal at reference level and for reference levels – input attenuation + preamp gain of –10 to –70 dBm)		–10 dBm (uncorrected), characteristic
Impedance		50 Ω, nominal

	Specifications	Supplemental Information
AUX VIDEO OUT (<i>Option A4J or AYX</i>)		RBW ≥ 1 kHz
Connector	BNC female	
Amplitude Range (into >10 kΩ)		0 to 1 V (uncorrected), characteristic

	Specifications	Supplemental Information
HI SWP IN (Option A4J or AYW)		
Connector	BNC female	
Input		Open collector, low resets and holds the sweep (5 V TTL)

	Specifications	Supplemental Information
HI SWP OUT (Option A4J or AYW)		
Connector	BNC female	
Output		High = sweep ^a , Low = retrace (5 V TTL)

a. High sweep may be high longer than the indicated sweep times.

	Specifications	Supplemental Information
SWP OUT (Option A4J or AYW)		
Connector	BNC female	
Amplitude		0 to +10 V ramp, characteristic

	Specifications	Supplemental Information
GPIB Interface (Option A4H)		
Connector	IEEE-488 bus connector	
GPIB Codes		SH1, AH1, T6, SR1, RL1, PP0, DC1, C1, C2, C3 and C28

	Specifications	Supplemental Information
Serial Interface (Option IAX)		
Connector	9-pin D-SUB male	RS-232

	Specifications	Supplemental Information
Parallel Interface (Option A4H or IAX)		
Connector	25-pin D-SUB female	Printer port only

	Specifications	Supplemental Information
EXT VIDEO IN/TV TRIG OUT^a (<i>Option B7B or BAA</i>) Connector Impedance (<i>Option BAA without Option B7B</i>) (<i>Option BAA with Option B7B</i>) External Video Input Video Amplitude TV Trigger Output Amplitude	BNC Female (75 Ω)	EXT VIDEO IN is the Baseband composite video input for TV trigger and picture on screen. TV TRIG OUT is the TV trigger output. 75 Ω, nominal Feature not implemented 1 V _{p-p} , nominal, characteristic Positive edge indicates start of selected TV line after sync. pulse TTL (0 V and 3.4 V with 75 Ω series resistance), characteristic

a. This connector is labelled EXT VIDEO IN on older spectrum analyzers and EXT VIDEO IN/TV TRIG OUT on newer spectrum analyzers.

	Specifications	Supplemental Information
EXT VIDEO OUT (<i>Option B7B or BAA</i>) Connector Impedance (<i>Option BAA without Option B7B</i>) Amplitude (<i>Option BAA with Option B7B</i>) Amplitude TV Source: SA TV Source and EXT VIDEO IN (<i>Option 106</i>) Connector Impedance Amplitude	BNC female (75 Ω) BNC female (75 Ω)	Baseband video output RBW ≥ 1 kHz 75 Ω, nominal 0 to 1 V (uncorrected), characteristic 0 to 1 V (uncorrected), characteristic Same as level at EXT VIDEO IN/TV TRIG OUT, characteristic 75 Ω, nominal 0 to 1 V (uncorrected), characteristic

	Specifications	Supplemental Information
EXT FRAME SYNC <i>(Option B7D)</i>		
Connector	BNC, female	
Level		5 V TTL

Regulatory Information

CAUTION

This product is designed for use in Installation Category II and Pollution Degree 2 per IEC 1010 and 664 respectively.

NOTE

This product has been designed and tested in accordance with IEC Publication 1010, Safety Requirements for Electronic Measuring Apparatus, and has been supplied in a safe condition. The instruction documentation contains information and warnings which must be followed by the user to ensure safe operation and to maintain the product in a safe condition.



The CE mark is a registered trademark of the European Community (if accompanied by a year, it is the year when the design was proven).



The CSA mark is the Canadian Standards Association safety mark.

ISM 1-A

This is a symbol of an Industrial Scientific and Medical Group 1 Class A product. (CISPR 11, Clause 4)

Declaration of Conformity

DECLARATION OF CONFORMITY

According to ISO/IEC Guide 22 and CEN/CENELEC EN 45014

Manufacturer's Name: Agilent Technologies, Inc.

Manufacturer's Address: 1400 Fountaingrove Parkway
Santa Rosa, CA 95403-1799
USA

Declares that the products

Product Name: Spectrum Analyzer

Model Number: E4401B, E4402B, E4403B, E4404B,
E4405B, E4407B, E4408B, E4411B

Product Options: This declaration covers all options of the above products.

Conform to the following product specifications:

EMC: IEC 61326-1:1997+A1:1998 / EN 61326-1:1997+A1:1998

<u>Standard</u>	<u>Limit</u>
CISPR 11:1990 / EN 55011-1991	Group 1, Class A
IEC 61000-4-2:1995+A1998 / EN 61000-4-2:1995	4 kV CD, 8 kV AD
IEC 61000-4-3:1995 / EN 61000-4-3:1995	3 V/m, 80 - 1000 MHz
IEC 61000-4-4:1995 / EN 61000-4-4:1995	0.5 kV sig., 1 kV power
IEC 61000-4-5:1995 / EN 61000-4-5:1996	0.5 kV L-L, 1 kV L-G
IEC 61000-4-6:1996 / EN 61000-4-6:1998	3 V, 0.15 - 80 MHz
IEC 61000-4-11:1994 / EN 61000-4-11:1998	1 cycle, 100%

Safety: IEC 61010-1:1990 + A1:1992 + A2:1995 / EN 61010-1:1993 +A2:1995
CAN/CSA-C22.2 No. 1010.1-92

Supplementary Information:

The products herewith comply with the requirements of the Low Voltage Directive 73/23/EEC and the EMC Directive 89/336/EEC and carry the CE-marking accordingly.



Santa Rosa, CA, USA 17 April 2000

Greg Pfeiffer/Quality Engineering Manager

For further information, please contact your local Agilent Technologies sales office, agent or distributor.

About This Chapter

This chapter contains specifications and characteristics for the Agilent E4404B spectrum analyzer. The distinction between specifications and characteristics is described as follows.

- Specifications describe the performance of parameters covered by the product warranty. (The temperature range is 0 °C to 55 °C, unless otherwise noted.)
- Characteristics describe product performance that is useful in the application of the product, but is not covered by the product warranty.
- Typical performance describes additional product performance information that is not covered by the product warranty. It is performance beyond specification that 80% of the units exhibit with a 95% confidence level over the temperature range 20 to 30 °C. Typical performance does not include measurement uncertainty.
- Nominal values indicate the expected performance, or describe product performance that is useful in the application of the product, but is not covered by the product warranty.

The following conditions must be met for the analyzer to meet its specifications.

- o The analyzer is within the one year calibration cycle.
- o If **Auto Align All** is selected:
 - After 2 hours of storage within the operating temperature range.
 - 5 minutes after the analyzer is turned on with sweep times less than 4 seconds.
 - After the front-panel amplitude reference is connected to the INPUT, and **Align Now RF** has been run, after the analyzer is turned on. And, once every 24 hours, or if ambient temperature changes more than 30 °C¹.
- o If **Auto Align Off** is selected:
 - When the analyzer is at a constant temperature, within the operating temperature range, for a minimum of 90 minutes.
 - After the analyzer is turned on for a minimum of 90 minutes, the front panel amplitude reference has been connected to the INPUT, and **Align Now All** has been run.
 - When **Align Now All** is run:
 - Every hour
 - If the ambient temperature changes more than 3 °C

1. 10 °C if Preamp (*Option IDS*) is active.

- If the 10 MHz reference changes
- When **Align Now RF** is run (with the front-panel amplitude reference connected to the INPUT):
 - Every 24 hours
 - If the ambient temperature changes more than 30 °C¹
- o If **Auto Align All but RF** is selected:
 - When the analyzer is at a constant temperature, within the operating temperature range, for a minimum of 90 minutes.
 - After the analyzer is turned on for a minimum of 90 minutes, the front panel amplitude reference has been connected to the INPUT, and **Align Now RF** has been run.
 - When **Align Now RF** is run (with the front-panel amplitude reference connected to the INPUT):
 - Every hour
 - If the ambient temperature changes more than 3 °C

1. 10 °C if Preamp (*Option 1DS*) is active.

Frequency

	Specifications	Supplemental Information
Frequency Range		
dc Coupled	9 kHz to 6.7 GHz	30 Hz to 6.7 GHz, characteristic
(<i>Option UKB</i>)	100 Hz to 6.7 GHz	
ac Coupled	100 kHz to 6.7 GHz	
Preamp On (<i>Option 1D5</i>)	1 MHz to 3.0 GHz	

	Specifications	Supplemental Information
Frequency Reference		
Aging Rate	$\pm 2 \times 10^{-6}$ /year	$\pm 1.0 \times 10^{-7}$ /day, characteristic
Settability	$\pm 5 \times 10^{-7}$	
Temperature Stability	$\pm 5 \times 10^{-6}$	

	Specifications	Supplemental Information
High Stability Frequency Reference (<i>Option 1D5</i>)		
Aging Rate	$\pm 1 \times 10^{-7}$ /year	$\pm 5 \times 10^{-10}$ /day, 7-day average after being powered on for 7 days, characteristic
Settability	$\pm 1 \times 10^{-8}$	
Temperature Stability		
20 to 30 °C	$\pm 1 \times 10^{-8}$	
0 to 55 °C	$\pm 5 \times 10^{-8}$	
Warm-up (Internal frequency reference selected)		
After 5 minutes		$< \pm 1 \times 10^{-7}$ of final frequency, ^a characteristic
After 15 minutes		$< \pm 1 \times 10^{-8}$ of final frequency, ^a characteristic

a. Final frequency is defined as frequency 60 minutes after power-on with analyzer set to internal frequency reference.

	Specifications	Supplemental Information
Frequency Readout Accuracy (Start, Stop, Center, Marker)	$\pm((\text{frequency indication} \times \text{frequency reference error}^{\text{a}}) + 0.5\% \text{ of span} + \frac{\text{span}}{\text{sweep points} - 1} + 15\% \text{ of RBW} + 10 \text{ Hz})$	

a. Frequency reference error = (aging rate × period of time since adjustment + settability + temperature stability).

	Specifications	Supplemental Information
Marker Frequency Counter Resolution Accuracy ^a	Selectable from 1 Hz to 100 kHz $\pm(\text{marker frequency} \times \text{frequency reference error}^{\text{b}} + \text{counter resolution})$	For RBW ≥ 1 kHz

a. Marker level to displayed noise level > 25 dB, RBW/ Span ≥ 0.002, frequency offset = 0 Hz.

b. Frequency reference error = (aging rate × period of time since adjustment + settability + temperature stability).

	Specifications	Supplemental Information
Frequency Span Range Resolution Accuracy ^a	0 Hz (zero span), 100 Hz to 6.7 GHz 2 Hz $\pm(0.5\% \text{ of span} + 2 \times \frac{\text{span}}{\text{sweep points} - 1})$	

a. Applies to each sweep segment.

	Specifications	Supplemental Information
Sweep Time Range Span > 0 Hz Span = 0 Hz Tracking Generator On (Option 1DN)	1 ms to 4000 s ^a 10 μs to 4000 s ^{a,b}	$\frac{\text{sweep points} - 1}{100 \text{ kHz}}$ to 4000 s 50 ms is the minimum sweep time

	Specifications	Supplemental Information
Fast Time-domain Sweep (<i>Option AYX</i>) (For Span = 0 Hz, RBW ≥ 1 kHz)	50 ns to 4000 s ^{c,d}	$\frac{\text{sweep points} - 1}{20 \text{ MHz}}$ to 4000 s
DSP and fast ADC (<i>Option B7D</i>) (For Span = 0 Hz, RBW ≥ 1 kHz)	25 ns to 4000 s ^e	$\frac{\text{sweep points} - 1}{40 \text{ MHz}}$ to 4000 s
Accuracy (Span = 0 Hz)		
10 μs to 4000 s ^{a,b}	±1%	
(<i>Option AYX</i>)	±1%	
50 ns to 4000 s ^{c,d}		
(<i>Option B7D</i>)	±1%	
25 ns to 4000 s ^e		
Sweep Trigger ^{f,g}	Free Run, Single, Line, Video ^h , External, Delayed, Offset ⁱ	
(<i>Option 1D6</i>)	Add Gate	
(<i>Option B7B</i>)	Add TV	
Delayed Trigger ^{g,j}		
Range	1 μs to 400 s	
Resolution	$\frac{\text{delay in seconds}}{65000}$ rounded up to nearest μs	
Accuracy	±(500 ns + (0.01% of delay))	
Offset Trigger ⁱ		
Resolution	$\frac{\text{sweep time}}{\text{sweep points} - 1}$	
Range	±327 ms to ±12.3 ks	Where ST = sweep time and SP = sweep points $\frac{-32766 \times \text{ST}}{\text{SP} - 1}$ to $\frac{(32766 - \text{SP}) \times \text{ST}}{\text{SP} - 1}$
Fast Time-domain sweep (<i>Option AYX</i>) (For sweep times $\frac{\text{sweep points} - 1}{20 \text{ MHz}}$ to $\frac{\text{sweep points} - 1}{100 \text{ kHz}}$)	±1.23 ms to ±245 ms	$\frac{-32766 \times \text{ST}}{\text{SP} - 1}$ to $\frac{(32766 - \text{SP}) \times \text{ST}}{\text{SP} - 1}$

	Specifications	Supplemental Information
DSP and fast ADC (<i>Option B7D</i>) (For sweep times $\frac{\text{sweep points} - 1}{40 \text{ MHz}}$ to $\frac{\text{sweep points} - 1}{100 \text{ kHz}}$)	$\pm 13 \text{ ms}$ to $\pm 5.15 \text{ s}$	$\frac{-524031 \times \text{ST}}{\text{SP} - 1}$ to $\frac{(524031 - \text{SP}) \times \text{ST}}{\text{SP} - 1}$

- For firmware revisions prior to A.04.00, 5 ms to 2000 s.
- For firmware revisions prior to A.05.00, 1 ms to 4000 s.
- For firmware revisions prior to A.04.00, 20 μs to 2000 s.
- For firmware revisions prior to A.05.00, 5 μs to 4000 s.
- For firmware revisions prior to A.05.00, 2.5 μs to 4000 s.
- Gate cannot be used simultaneously with delayed or TV trigger (*Option B7B*).
- Auto align is suspended in video, external, gate, and delayed trigger modes while waiting for a trigger event to occur.
- Unavailable when $\text{RBW} \leq 300 \text{ Hz}$ (*Option 1DR*).
- For firmware revision A.04.00 or later.
- Delayed trigger is available with line, external trigger, and TV trigger (*Option B7B*).

	Specifications	Supplemental Information
Sweep (trace) Points		
Range		
Span > 0 Hz	101 to 8192 ^a	
Span = 0 Hz	2 to 8192 ^{a,b}	

- For firmware revisions prior to A.04.00, 401 points.
- For firmware revisions prior to A.05.00, 101 to 8192 points.

	Specifications	Supplemental Information
Resolution Bandwidth (RBW)		
Range		
-3 dB bandwidth	1 kHz to 3 MHz, in 1-3-10 sequence, 5 MHz	
-6 dB bandwidth (EMI)	9 kHz and 120 kHz	
(<i>Option 1DR</i>)		
-3 dB bandwidth	Adds 10, 30, 100, 300 Hz	
-6 dB bandwidth (EMI)	Add 200 Hz	
Accuracy		
1 kHz to 3 MHz RBW	$\pm 15\%$	Only available in spans $\leq 5 \text{ MHz}$, sweep times $\geq \frac{\text{sweep points} - 1}{100 \text{ kHz}}$, and not usable with tracking generator on. (<i>Option 1DN</i>)

	Specifications	Supplemental Information
5 MHz RBW	$\pm 30\%$	Synchronously tuned four poles, approximately Gaussian shape Digital, approximately Gaussian shape <15:1, characteristic <5:1, characteristic
10 Hz to 300 Hz RBW (Option IDR)	$\pm 10\%$	
Shape		
1 kHz to 5 MHz RBW		
10 Hz to 300 Hz RBW (Option IDR)		
Selectivity (60 dB/3 dB bandwidth ratio)		
1 kHz to 5 MHz RBW		
10 Hz to 300 Hz RBW (Option IDR)		

	Specifications	Supplemental Information
Video Bandwidth (VBW) (-3 dB)		
Range	30 Hz to 1 MHz in 1-3-10 sequence	3 MHz, characteristic
(Option IDR)	Adds 1, 3, 10 Hz for RBW's <1 kHz	
Accuracy		$\pm 30\%$, characteristic
Shape		Post detection, single pole low-pass filter used to average displayed noise Video bandwidths below 30 Hz are digital bandwidths with anti-aliasing filtering.

	Specifications	Supplemental Information
Stability		
Noise Sidebands (Offset from CW signal with 1 kHz RBW, 30 Hz VBW and sample detector)		
≥1 kHz (<i>Option 1DR, 1D5</i>)		≤ -78 dBc/Hz, typical
≥10 kHz	≤ -90 dBc/Hz	≤ -94 dBc/Hz, typical
≥20 kHz	≤ -100 dBc/Hz	≤ -105 dBc/Hz, typical
≥30 kHz	≤ -106 dBc/Hz	≤ -112 dBc/Hz, typical
≥100 kHz	≤ -119 dBc/Hz	≤ -122 dBc/Hz, typical
≥1 MHz	≤ -125 dBc/Hz	≤ -127 dBc/Hz, typical
≥5 MHz	≤ -127 dBc/Hz	≤ -129 dBc/Hz, typical
≥10 MHz	≤ -131 dBc/Hz	≤ -136 dBc/Hz, typical
<i>(Option 120)</i>		
≥1 MHz	≤ -133 dBc/Hz	≤ -136 dBc/Hz, typical
≥5 MHz	≤ -135 dBc/Hz	≤ -139 dBc/Hz, typical
≥10 MHz	≤ -137 dBc/Hz	≤ -141 dBc/Hz, typical
Residual FM		
1 kHz RBW, 1 kHz VBW <i>(Option 1D5)</i>	≤150 Hz p-p in 100 ms	
10 Hz RBW, 10 Hz VBW <i>(Option 1DR and 1D5)</i>	≤100 Hz p-p in 100 ms	
10 Hz RBW, 10 Hz VBW <i>(Option 1DR)</i>	≤2 Hz p-p in 20 ms	≤10 Hz p-p in 20 ms, characteristic
System-Related Sidebands, offset from CW signal		
≥30 kHz	≤ -65 dBc	
Line-Related Sidebands, offset from CW signal <i>(Option 1DR)</i>		
<300 Hz		≤ -50 dBc, characteristic
>300 Hz to 30 kHz		≤ -55 dBc, characteristic

Noise Sidebands Normalized to 1 Hz Versus Offset from Carrier

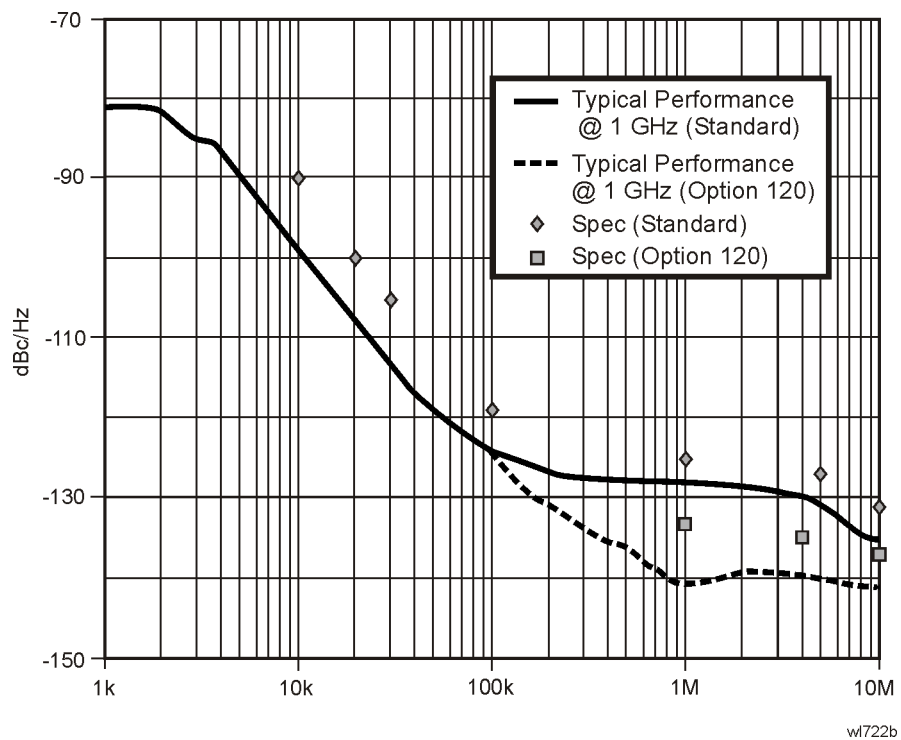

Amplitude

Amplitude specifications do not apply for the negative peak detector mode.

	Specifications	Supplemental Information
Measurement Range	Displayed Average Noise Level to Maximum Safe Input Level	
Input Attenuator Range	0 to 65 dB, in 5 dB steps	0 to 75 dB, in 5 dB steps, characteristic

	Specifications	Supplemental Information
Maximum Safe Input Level		
Average Continuous Power (Input attenuator setting ≥ 5 dB)	+30 dBm (1 W)	
Peak Pulse Power (for <10 μ sec pulse width, $<1\%$ duty cycle, and input attenuation ≥ 30 dB)	+50 dBm (100 W)	
dc		
dc Coupled	0 Vdc	
ac Coupled	50 Vdc	

	Specifications	Supplemental Information
1 dB Gain Compression		
Total power at input mixer ^{a,b}		
50 MHz to 3.0 GHz	0 dBm	
3.0 GHz to 6.7 GHz	0 dBm	
Preamp On (<i>Option 1DS</i>)		
Total power at the preamp ^c		-20 dBm, characteristic

- Mixer power level (dBm) = input power (dBm) – input attenuation (dB).
- For resolution bandwidths 1 kHz to 30 kHz, the maximum input signal amplitude must be \leq reference level +10 dB.
- Total power at the preamp (dBm) = total power at the input (dBm) – input attenuation (dB).

	Specifications		Supplemental Information	
Displayed Average Noise Level (Input terminated, 0 dB attenuation, sample detector, Reference Level = -70 dBm)				
	1 kHz RBW 30 Hz VBW	10 Hz RBW 1 Hz VBW (Option IDR)	1 kHz RBW 30 Hz VBW (typical)	10 Hz RBW 1 Hz VBW (Option IDR) (typical)
30 Hz to 9 kHz (Option UKB)				≤ -93 dBm
9 kHz to 100 kHz				≤ -109 dBm
100 kHz to 1 MHz				≤ -135 dBm
1 MHz to 10 MHz			≤ -117 dBm	≤ -137 dBm
1 MHz to 10 MHz (Option I20)			≤ -120 dBm	≤ -139 dBm
10 MHz to 1.0 GHz	≤ -116 dBm	≤ -135 dBm	≤ -119 dBm	≤ -139 dBm
1.0 GHz to 2.0 GHz	≤ -116 dBm	≤ -135 dBm	≤ -120 dBm	≤ -140 dBm
2.0 GHz to 3.0 GHz	≤ -112 dBm	≤ -131 dBm	≤ -118 dBm	≤ -138 dBm
3.0 GHz to 6.0 GHz	≤ -112 dBm	≤ -131 dBm	≤ -118 dBm	≤ -138 dBm
6.0 GHz to 6.7 GHz	≤ -111 dBm	≤ -130 dBm	≤ -117 dBm	≤ -137 dBm
Preamp On (Option IDS)	1 kHz RBW 30 Hz VBW	10 Hz RBW 1 Hz VBW (Option IDR)	1 kHz RBW 30 Hz VBW (typical)	10 kHz RBW 1 Hz VBW (Option IDR) (typical)
0 to 55 °C				
10 MHz to 1.0 GHz	≤ -131 dBm	≤ -150 dBm		
1.0 GHz to 2.0 GHz	≤ -131 dBm	≤ -150 dBm		
2.0 GHz to 3.0 GHz	≤ -127 dBm	≤ -146 dBm		
20 to 30 °C				
1 MHz to 10 MHz			≤ -135 dBm	≤ -155 dBm
10 MHz to 1.0 GHz	≤ -132 dBm	≤ -151 dBm	≤ -137 dBm	≤ -157 dBm
1.0 GHz to 2.0 GHz	≤ -132 dBm	≤ -151 dBm	≤ -135 dBm	≤ -155 dBm
2.0 GHz to 3.0 GHz	≤ -130 dBm	≤ -149 dBm	≤ -132 dBm	≤ -152 dBm

	Specifications	Supplemental Information
Display Range		
Log Scale	Ten divisions displayed; 0.1, 0.2, 0.5 dB/division and 1 to 20 dB/division in 1 dB steps	
RBW \geq 1 kHz	Calibrated 0 to -85 dB from Reference Level	
RBW \leq 300 Hz (<i>Option IDR</i>)	Calibrated 0 to -120 dB ^a from Reference Level	
Linear Scale	Ten divisions	
Scale Units	dBm, dBmV, dB μ V, dB μ A, A, V, and W	
(<i>Option BAA, 106</i>)	Add Hz	

- a. 0 to -70 dB range when span = 0 Hz, or when IF Gain fixed:
(:DISPlay:WINDow:TRACe:Y[:SCALe]:LOG:RANGe:AUTO OFF).

	Specifications	Supplemental Information
Marker Readout Resolution		
Log scale		
RBW \geq 1 kHz	0 to -85 dB from ref level	0.04 dB
RBW \leq 300 Hz (<i>Option IDR</i>)	0 to -120 dB from ref level	0.04 dB
Linear scale		0.01% of Reference Level
Fast Sweep Times for Zero Span		
(<i>Option AYX</i>) ^a		
For sweep times		
$\frac{\text{sweep points} - 1}{20 \text{ MHz}}$ to		
$\frac{\text{sweep points} - 1}{100 \text{ kHz}}$		
Log	0 to -85 dB from ref level	0.3 dB
Linear		0.3% of Reference Level for linear scale

	Specifications	Supplemental Information
<p><i>(Option B7D)</i> For sweep times $\frac{\text{sweep points} - 1}{40 \text{ MHz}}$ to $\frac{\text{sweep points} - 1}{100 \text{ kHz}}$</p> <p>Log 0 to -85 dB from ref level</p> <p>Linear</p>	<p>0.2 dB</p> <p>0.2% of Reference Level for linear scale</p>	

a. For firmware revisions prior to A.04.00, 20 μ s to <5 ms.

	Specifications	Supplemental Information
<p>Frequency Response</p> <p>50 Ω, Absolute^a/Relative</p> <p>10 dB attenuation (dc coupled)</p> <p>9 kHz to 3.0 GHz</p> <p>20 to 30 °C</p> <p>0 to 55 °C</p> <p>(ac coupled)</p> <p>100 kHz to 3.0 GHz</p> <p>20 to 30 °C</p> <p>0 to 55 °C</p> <p>800 MHz to 1.0 GHz^b</p> <p>20 to 30 °C</p> <p>0 to 55 °C</p> <p>1.7 GHz to 2.0 GHz</p> <p>20 to 30 °C</p> <p>0 to 55 °C</p>	<p>± 0.46 dB</p> <p>± 0.76 dB</p> <p>± 0.50 dB</p> <p>± 1.0 dB</p> <p>± 0.50 dB</p> <p>± 1.0 dB</p> <p>± 0.50 dB</p> <p>± 1.0 dB</p>	<p>± 0.14 dB, typical</p> <p>± 0.10 dB, typical</p> <p>± 0.08 dB, typical</p>

	Specifications	Supplemental Information
<i>(Option UKB)</i>		
100 Hz to 3.0 GHz (dc coupled)		
20 to 30 °C	±0.50 dB	
0 to 55 °C	±1.00 dB	
30 Hz to 3.0 GHz (dc coupled)		
20 to 30 °C		±0.5 dB, characteristic
0 to 55 °C		±1.0 dB, characteristic
Absolute ^a /Relative, Preamp On <i>(Option IDS)</i>		
0 dB attenuation		
1 MHz to 3.0 GHz		
20 to 30 °C	±1.5 dB	
0 to 55 °C	±2.0 dB	
800 MHz to 1.0 GHz		
20 to 30 °C	±1.5 dB	±0.35 dB, typical
0 to 55 °C	±2.0 dB	
1.7 GHz to 2.0 GHz		
20 to 30 °C	±1.5 dB	±0.26 dB, typical
0 to 55 °C	±2.0 dB	
Preselector centered for frequency >3.0 GHz		
10 dB attenuation		
3.0 GHz to 6.7 GHz (ac or dc coupled)		
Absolute ^a		
20 to 30 °C	±1.5 dB	
0 to 55 °C	±2.5 dB	
Relative		
20 to 30 °C	±1.3 dB	
0 to 55 °C	±1.5 dB	

- a. Absolute frequency response values are referenced to the amplitude at 50 MHz.
b. This specification applies only to analyzers with serial numbers ≥ US39440498.

	Specifications	Supplemental Information
Input Attenuation Switching Uncertainty at 50 MHz		
Attenuator Setting		
0 dB to 5 dB	±0.3 dB	
10 dB	Reference	
15 dB	±0.3 dB	
20 to 65 dB attenuation	±(0.1 dB + 0.01 × Attenuator Setting)	

Attenuation Accuracy Relative to the 10 dB Attenuator Setting, Characteristic		
	Frequency Range	
Attenuation	dc–3.0 GHz	3.0–6.7 GHz
0 dB	±0.3 dB	±0.5 dB
5 dB	±0.3 dB	±0.5
10 dB	Reference	Reference
15 dB	±0.4 dB	±0.5 dB
20 dB	±0.4 dB	±0.5 dB
25 dB	±0.5 dB	±0.6 dB
30 dB	±0.5 dB	±0.6 dB
35 dB	±0.6 dB	±0.7 dB
40 dB	±0.6 dB	±0.7 dB
45 dB	±0.7 dB	±1.0 dB
50 dB	±0.7 dB	±1.0 dB
55 dB	±0.9 dB	±1.1 dB
60 dB	±0.9 dB	±1.1 dB
65 dB	±1.0 dB	±1.6 dB

	Specifications	Supplemental Information
Preamp (Option 1DS)		Refer also to Displayed Average Noise Level specification
Gain		+20 dB, nominal ^a
Noise figure		5 dB, characteristic

a. Amplifier is between the input attenuator and the input mixer.

	Specifications	Supplemental Information
Absolute Amplitude Accuracy		
At reference settings ^a	±0.34 dB	±0.13 dB, typical
Preamp On ^b (Option 1DS)	±0.37 dB	±0.14 dB, typical
Overall Amplitude Accuracy^c		
20 to 30 °C	± (0.54 dB + Absolute Frequency Response)	

- a. Settings are: reference level -20 dBm; input attenuation 10 dB; dc coupled; center frequency 50 MHz; RBW 1 kHz; VBW 1 kHz; scale linear or log; span 2 kHz; sweep time coupled, sample detector, signal at reference level.
- b. Settings are: reference level -30 dBm; input attenuation 0 dB; dc coupled; center frequency 50 MHz; RBW 1 kHz; VBW 1 kHz; scale linear or log; span 2 kHz; sweep time coupled, signal at reference level.
- c. For reference level 0 to -50 dBm; input attenuation 10 dB; dc coupled; RBW 1 kHz; VBW 1 kHz; scale log, log range 0 to -50 dB from reference level; sweep time coupled; signal input 0 to -50 dBm; span ≤20 kHz.

	Specifications	Supplemental Information	
RF Input VSWR (at tuned frequency)		characteristic	characteristic
Attenuator setting 0 dB		(dc coupled)	(ac coupled)
9 kHz to 100 kHz		≤3.0:1	
100 kHz to 6.7 GHz		≤3.0:1	≤3.0:1
100 Hz to 100 kHz (Option UKB)		≤1.1:1	
Attenuator setting 5 dB		(dc coupled)	(ac coupled)
9 kHz to 100 kHz		≤2.0:1	
100 kHz to 300 kHz		≤1.4:1	≤2.3:1
300 kHz to 1.0 MHz		≤1.4:1	≤1.6:1
1.0 MHz to 3.0 GHz		≤1.4:1	≤1.4:1
3.0 GHz to 6.7 GHz		≤1.4:1	≤1.7:1

	Specifications	Supplemental Information	
100 Hz to 100 kHz (Option UKB)		≤1.1:1	
Attenuator setting 10 to 65 dB		(dc coupled)	(ac coupled)
9 kHz to 100 kHz		≤2.0:1	
100 kHz to 300 kHz		≤1.3:1	≤2.1:1
300 kHz to 1.0 MHz		≤1.3:1	≤1.5:1
1.0 MHz to 3.0 GHz		≤1.3:1	≤1.3:1
3.0 GHz to 6.7 GHz		≤1.3:1	≤1.5:1
100 Hz to 100 kHz (Option UKB)		≤1.1:1	

	Specifications	Supplemental Information	
Auto Alignment^a			
Sweep-to-sweep variation		±0.1 dB, characteristic	

a. Set **Auto Align** to **Off** and use **Align Now, All** to eliminate this variation.

	Specifications	Supplemental Information	
Resolution Bandwidth Switching Uncertainty (at Reference Level)			
1 kHz RBW	Reference		
3 kHz to 3 MHz RBW	±0.3 dB		
5 MHz RBW	±0.6 dB		
10 Hz to 300 Hz RBW (Option 1DR)	±0.3 dB		

	Specifications	Supplemental Information	
Reference Level			
Range	–149.9 dBm to maximum mixer level + attenuator setting		
Resolution			
Log Scale	±0.1 dB		
Linear Scale	±0.12% of Reference Level		

	Specifications	Supplemental Information
<p>Accuracy (at a fixed frequency, a fixed attenuator, and referenced to -30 dBm (-10 dBm, Preamp On (<i>Option 1DS</i>)))</p> <p>Reference Level (dBm) – input attenuator setting (dB) + preamp gain (dB)</p> <p>-10 dBm to > -60 dBm</p> <p>-60 dBm to > -85 dBm</p> <p>-85 dBm to -90 dBm</p>	<p>±0.3 dB</p> <p>±0.5 dB</p> <p>±0.7 dB</p>	

	Specifications	Supplemental Information
<p>Display Scale Switching Uncertainty</p> <p>Switching between Linear and Log</p> <p>Log Scale Switching</p>	<p>±0.15 dB at reference level</p> <p>No error</p>	

	Specifications	Supplemental Information
<p>Display Scale Fidelity</p> <p>Log Maximum Cumulative</p> <p>RBW ≥ 1 kHz</p> <p>dB Below Reference Level</p> <p>0 dB Reference</p> <p>> 0 to 10 dB</p> <p>> 10 to 20 dB</p> <p>> 20 to 30 dB</p> <p>> 30 to 40 dB</p> <p>> 40 to 50 dB</p> <p>> 50 to 60 dB</p> <p>> 60 to 70 dB</p> <p>>70 to 80 dB</p> <p>>80 to 85 dB</p>	<p>0 dB</p> <p>±0.22 dB</p> <p>±0.24 dB</p> <p>±0.26 dB</p> <p>±0.40 dB</p> <p>±0.57 dB</p> <p>±0.57 dB</p> <p>±0.66 dB</p> <p>±0.66 dB</p> <p>±1.15 dB</p>	<p>±0.08 dB, typical</p> <p>±0.09 dB, typical</p> <p>±0.10 dB, typical</p> <p>±0.23 dB, typical</p> <p>±0.35 dB, typical</p> <p>±0.35 dB, typical</p> <p>±0.39 dB, typical</p> <p>±0.46 dB, typical</p> <p>±0.79 dB, typical</p>

	Specifications	Supplemental Information
<p>RBW \leq 300 Hz (<i>Option IDR</i>)</p> <p>Span $>$ 0 Hz</p> <p>Auto range On</p> <p>0 to 98 dB below reference level</p> <p>$>$ 98 to 120 dB below reference level</p> <p>Auto range Off</p> <p>0 to 60 dB below reference level</p> <p>$>$ 60 to 70 dB below reference level</p> <p>Span = 0 Hz^a</p> <p>0 to 60 dB below reference level</p> <p>$>$ 60 to 70 dB below reference level</p> <p>Log Incremental Accuracy</p> <p>0 to 80 dB^b below reference level</p> <p>Linear Accuracy</p>	<p>$\pm(0.3 \text{ dB} + 0.01 \times \text{dB from reference level})$</p> <p>$\pm(0.3 \text{ dB} + 0.015 \times \text{dB from reference level})$</p> <p>$\pm 1.5 \text{ dB}$</p> <p>$\pm(0.3 \text{ dB} + 0.015 \times \text{dB from reference level})$</p> <p>$\pm 1.5 \text{ dB}$</p> <p>$\pm 0.4 \text{ dB}/4 \text{ dB}$</p> <p>$\pm 2\%$ of Reference Level</p>	<p>$\pm 2.0 \text{ dB}$, characteristic</p>

- a. The SCPI command for auto range off is:
(:DISPlay:WINDow:TRACe:Y[:SCALe]:LOG:RANGe:AUTO OFF)
- b. 0 to -50 dB for RBWs \leq 300 Hz and span = 0 Hz, or when auto ranging is off.

	Specifications	Supplemental Information
<p>Spurious Responses</p> <p>Second Harmonic Distortion</p> <p>Input Signal</p> <p>10 MHz to 500 MHz</p> <p>500 MHz to 1.5 GHz</p> <p>1.5 GHz to 2.0 GHz</p>	<p>$< -65 \text{ dBc}$ for -30 dBm signal at input mixer^a</p> <p>$< -75 \text{ dBc}$ for -30 dBm signal at input mixer^a</p> <p>$< -85 \text{ dBc}$ for -10 dBm signal at input mixer^a</p>	<p>+35 dBm SHI (second harmonic intercept)</p> <p>+45 dBm SHI</p> <p>+75 dBm SHI</p>

	Specifications	Supplemental Information
2.0 GHz to 3.35 GHz	$< -100 \text{ dBc}^b$ for -10 dBm signal at input mixer ^a	+90 dBm SHI
Preamp On (<i>Option IDS</i>) 10 MHz to 1.5 GHz		-5 dBm SHI, characteristic
Third Order Intermodulation Distortion		
10 MHz to 100 MHz		+7 dBm TOI (third order intercept), characteristic
100 MHz to 3 GHz	$< -85 \text{ dBc}$ for two -30 dBm signals at input mixer ^a and $>50 \text{ kHz}$ separation	+12.5 dBm TOI +16 dBm TOI, typical
3.0 GHz to 6.7 GHz	$< -82 \text{ dBc}$ for two -30 dBm signals at input mixer ^a and $>50 \text{ kHz}$ separation	+11 dBm TOI +18 dBm TOI, typical
Preamp On (<i>Option IDS</i>) 10 MHz to 3 GHz		-16 dBm TOI, characteristic
Other Input Related Spurious		
Inband Responses		
$>30 \text{ kHz}$ offset	$< -65 \text{ dBc}$ for -20 dBm signal at input mixer ^a	
Out-of-band Responses	$< -80 \text{ dBc}$ for -10 dBm signal at input mixer ^a	

a. Mixer power level (dBm) = input power (dBm) – input attenuation (dB).

b. or signal below displayed average noise level.

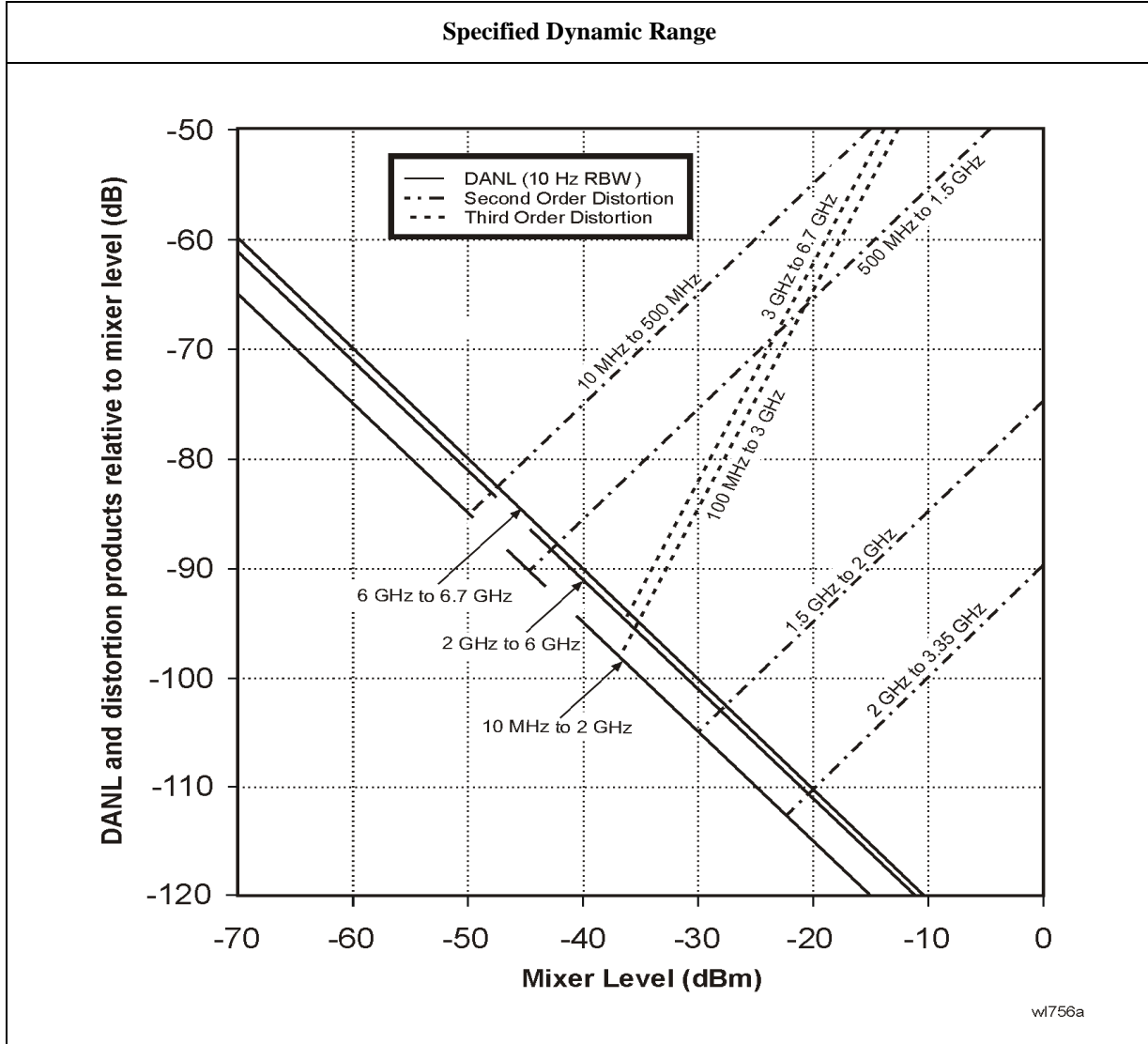

	Specifications	Supplemental Information
Residual Responses (Input terminated and 0 dB attenuation) 150 kHz to 6.7 GHz	< -90 dBm	

Options

Time Gated Spectrum Analysis (Option 1D6)

	Specifications	Supplemental Information
Gate Delay		
Range	1 μ s to 400 s	
Accuracy	$\pm(500 \text{ ns} + (0.01\% \times (\text{maximum of gate delay or length})))$	From gate trigger input to positive edge of gate output
Gate Length		
Range	1 μ s to 400 s	
Accuracy	$\pm(500 \text{ ns} + (0.01\% \times (\text{maximum of gate delay or length})))$	From positive edge to negative edge of gate output
Resolution	$((\text{maximum of gate delay or length in seconds})/65000)$ rounded up to nearest μ s	Dependent on the greater of gate delay or gate length
Additional Amplitude Error^a		
Log Scale	± 0.2 dB	
Linear Scale	$\pm 0.1\%$ of reference level	

a. While in gate mode.

Tracking Generator (Option 1DN)

The spectrum analyzer/tracking generator combination will meet its specification after a cable (8120-5148) and adapter are connected between RF OUT and INPUT and **Align Now, TG** has been run.

	Specifications	Supplemental Information
Warm-up	5 minutes	

	Specifications	Supplemental Information
Output Frequency Range	9 kHz to 3.0 GHz	

	Specifications	Supplemental Information
Minimum Resolution BW	1 kHz	Not usable with resolution bandwidths ≤ 300 Hz (<i>Option 1DR</i>)

	Specifications	Supplemental Information
Output Power Level		
Range	-2 to -66 dBm	
Resolution	0.1 dB	
Absolute Accuracy (at 50 MHz with coupled source attenuator, referenced to -20 dBm)	± 0.75 dB	
Vernier		
Range	8 dB	
Accuracy (with coupled source attenuator, 50 MHz, -20 dBm)		
Incremental	± 0.2 dB/dB	
Cumulative	± 0.5 dB, total	
Output Attenuator Range	0 to 56 dB in 8 dB steps	

	Specifications	Supplemental Information
Maximum Safe Reverse Level		+30 dBm (1 W), 50 Vdc, characteristic

	Specifications	Supplemental Information
Output Power Sweep		
Range	(-10 to -2 dBm) – (Source Attenuator Setting)	
Resolution	0.1 dB	
Accuracy (zero span)	<1 dB peak-to-peak	

	Specifications	Supplemental Information
Output Flatness		
Referenced to 50 MHz, -20 dBm		
9 kHz to 10 MHz	±3 dB	
10 MHz to 3 GHz	±2 dB	

	Specifications	Supplemental Information
Spurious Outputs		
(-2 dBm output)		
Harmonic Spurs		
TG Output 9 kHz to 20 kHz	≤ -15 dBc	
TG Output 20 kHz to 3 GHz	≤ -25 dBc	
Non-harmonic Spurs		
TG Output 9 kHz to 2 GHz	≤ -27 dBc	
TG Output 2 GHz to 3 GHz	≤ -23 dBc	
LO Feedthrough		
LO Frequency 3.921409 GHz to 6.9214 GHz	≤ -16 dBm	

	Specifications	Supplemental Information
Dynamic Range	Maximum Output Power Level – Displayed Average Noise Level	

	Specifications	Supplemental Information
Output Tracking Drift Swept Tracking Error		1.5 kHz/5 minute, characteristic Usable in 1 kHz RBW after 5 minutes of warm-up

	Specifications	Supplemental Information
RF Power-Off Residuals 9 kHz to 3 GHz		< -120 dBm, characteristic

	Specifications	Supplemental Information
Output Attenuator Repeatability 9 kHz to 300 MHz 300 MHz to 2 GHz 2 GHz to 3 GHz		±0.1 dB, characteristic ±0.2 dB, characteristic ±0.3 dB, characteristic

	Specifications	Supplemental Information
Output VSWR 0 dB attenuation ≥ 8 dB attenuation		<2.0:1, characteristic <1.5:1, characteristic

	Specifications	Supplemental Information
Output Attenuator Accuracy 0 dB 8 dB 16 dB 24 dB 32 dB 40 dB 48 dB 56 dB	Reference	±0.5 dB, characteristic ±0.5 dB, characteristic ±0.5 dB, characteristic ±0.6 dB, characteristic ±0.8 dB, characteristic ±1.0 dB, characteristic ±1.1 dB, characteristic

Tracking Generator Output Accuracy
Relative Accuracy (Referred to -20 dBm) = Output Attenuator Accuracy + Vernier Accuracy + Output Flatness
Absolute Accuracy = Relative Accuracy (Referred to -20 dBm) + Absolute Accuracy at 50 MHz

Bluetooth FM Demodulation (Option 106)

The FM demodulation characteristics will apply after an Align Now, FM Demod has been run.

	Specifications	Supplemental Information
Optimum Input Level		$\geq (-40 \text{ dBm} + \text{attenuator setting} - \text{preamp gain})$ and within 10 dB of the reference level
FM Deviation		
Range		$\pm 200 \text{ kHz}$, nominal
Resolution		Provides 400 Hz display annotation resolution, nominal
Accuracy ^a		
Input level = -30 dBm		$\pm 10 \text{ kHz}$, typical
Reference level = -30 dBm		$\pm 4 \text{ kHz}$ with video averaging On and averages ≥ 25
FM Rate = 500 kHz sine		
VBW = 3 MHz,		
RBW = 5 MHz,		
FM Deviation = 140 kHz		
Offset Error ^a		$\pm 1 \text{ kHz}$, typical
FM Bandwidth (-3 dB)		1.2 MHz, nominal

a. In time domain sweeps (span = 0 Hz).

Bluetooth Measurements Personality (Option 228)

The demodulation related nominals will apply after an Align Now, FM Demod has been run.

	Specifications	Supplemental Information
In-Band Frequency Range		
Bluetooth (ISM) Band	2400 to 2483.5 MHz	

	Specifications	Supplemental Information
Output Power (Option AYX or B7D)		
Range at RF Input	30 to -40 dBm	
(Option IDS)	30 to -60 dBm	
Absolute Amplitude Accuracy		See, "Absolute Amplitude Accuracy," on page 125.
Average type	Video, Power	
Average mode	Exponential, Repeat	
Trigger source	Video, RF burst ^a , External, Free Run	
Burst synch	RF Amplitude, Preamble ^b , None	

a. Requires Option B7E

b. Requires Option 106 Bluetooth FM demodulation.

	Specifications	Supplemental Information
Modulation Characteristics^a (Option 106 and AYX or B7D)		
Range at RF Input	30 to -40 dBm	
(Option IDS)	30 to -60 dBm	
FM Deviation		
Range		±200 kHz, nominal
Accuracy		±4 kHz, nominal (25 measurement averages, signal level > -30 dBm)
Payload data	11110000, 10101010, auto-detect	
Average mode	Exponential, Repeat	

	Specifications	Supplemental Information
Trigger source	Video, RF burst ^b , External, Free Run	
Burst synch	RF Amplitude, Preamble ^c , None	
Limits	$\Delta f_2/\Delta f_1$ lower, Δf_1 max lower/upper Δf_2	

- a. The DUT must have frequency hopping disabled.
- b. Requires Option B7E
- c. Requires Option 106 Bluetooth FM demodulation.

	Specifications	Supplemental Information
Carrier Frequency Drift ^a (Option 106 and AYZ or B7D)		
Range at RF Input	30 to -40 dBm	
(Option 1DS)	30 to -60 dBm	
Measurement range		± 100 kHz, nominal
Measurement accuracy		± 4 kHz, nominal (25 measurement averages, signal level > -30 dBm)
Average mode	Exponential, Repeat	
Trigger source	Video, RF burst ^b , External, Free Run	
Burst synch	Preamble ^c , None	

- a. The DUT must have frequency hopping disabled.
- b. Requires Option B7E
- c. Requires Option 106 Bluetooth FM demodulation.

	Specifications	Supplemental Information
Initial Carrier Frequency Tolerance (ICTF) ^a (Option 106 and AYZ or B7D)		
Range at RF Input	30 to -40 dBm	
(Option 1DS)	30 to -60 dBm	
Measurement range		± 100 kHz, nominal
Measurement accuracy		± 4 kHz, nominal (25 measurement averages, signal level > -30 dBm)

	Specifications	Supplemental Information
Average mode	Exponential, Repeat	
Trigger source	Video, RF burst ^b , External, Free Run	
Burst synch	RF Amplitude, Preamble ^c , None	
Limits	ICFT upper/lower	

- a. The DUT must have frequency hopping disabled.
- b. Requires Option B7E
- c. Requires Option 106 Bluetooth FM demodulation.

FM Demodulation (Option BAA)

The FM demodulation characteristics will apply after an **Align Now, FM Demod** has been run.

	Specifications	Supplemental Information
Optimum Input Level		$\geq (-60 \text{ dBm} + \text{attenuator setting} - \text{preamp gain})$ and within 30 dB of the reference level
FM Deviation		
Range		10 kHz to 1 MHz
Resolution		Provides 1 Hz display annotation resolution
FM Deviation Range		
10 kHz to 40 kHz		12 Hz, characteristic
>40 kHz to 200 kHz		60 Hz, characteristic
>200 kHz to 1 MHz		300 Hz, characteristic
Accuracy ^a		
FM Rate < FM BW/100, VBW $\geq (30 \times \text{FM Rate})$, RBW > the maximum of (30 \times FM deviation) or (30 \times FM Rate)		< (2% of FM deviation range + 2 \times Resolution), characteristic
Offset Error ^a		5% of FM Deviation Range + 300 Hz, characteristic
FM Bandwidth (-3 dB)		
FM Deviation Range		
10 kHz to 40 kHz		7.5 \times FM deviation range, characteristic
>40 kHz to 200 kHz		1.3 \times FM deviation range, characteristic
>200 kHz to 1 MHz		0.3 \times FM deviation range, characteristic

a. In time domain sweeps (span = 0 Hz).

TV Trigger and Picture On Screen (Option B7B)

Option BAA is required.

	Specifications	Supplemental Information
TV Trigger and Picture On Screen		TV Trigger initiates a sweep of the analyzer after the sync pulse of a selected line of a TV video field. Picture On Screen displays the TV picture on the analyzer display.
Amplitude Requirements TV Source: SA		Top 50% of linear display, characteristic
TV Source: EXT VIDEO IN		500 mVp-p to 2 Vp-p, characteristic
Compatible Standards	NTSC-M, NTSC-Japan, PAL-M, PAL-B,D,G,H,I, PAL-N, PAL-N Combination, SECAM-L	
Field Selection	Entire frame, even, odd	
Sync Polarity	Positive or negative	
TV Trigger		
Line Selection	1 to 525, or 1 to 625, standard dependent	

cdmaOne Measurement Personality (Option BAC)

Unless otherwise noted, all specifications are with RF input range auto, default cdmaOne measurement settings, and in the in-band frequency range. *Option B72* is required.

	Specifications	Supplemental Information
In-Band Frequency Range		
Cellular bands	824 to 870 MHz 869 to 925 MHz	
PCS bands	1715 to 1780 MHz 1805 to 1870 MHz 1850 to 1910 MHz 1930 to 1990 MHz	

	Specifications	Supplemental Information
Adjacent Channel Power Ratio^a		
Carrier power range at RF Input	30 to -20 dBm	
Dynamic range ^b		Referenced to average power of carrier in 1.23 MHz BW
Offset Frequency	Integration BW	
750 kHz	30 kHz	-70.0 dBc, characteristic
885 kHz	30 kHz	-73.5 dBc, characteristic
1.25625 MHz	12.5 kHz	-78.0 dBc, characteristic
1.98 MHz	30 kHz	-75.5 dBc, characteristic
2.75 MHz	1 MHz	-60.5 dBc, characteristic
Relative accuracy ^c	See Display Scale Fidelity	
Resolution	0.01 dB	

- This measurement is available with personality revisions of A.02.00 or later.
- IS-97A nominal base station test model levels (fraction of carrier power); Pilot: 0.20 (-7.0 dBc), Sync: 0.0471 (-13.3 dBc), Paging: 0.1882 (-7.3 dBc), 6 Traffic channels: 0.09412 (-10.3 dBc)
- Does not include uncertainty due to noise.

	Specifications	Supplemental Information
Channel Power (1.23 MHz Integration BW)		Integration BW range 1 kHz to 10 MHz
Range at RF Input	30 to -70 dBm	
Absolute power accuracy for in-band signal (Mean channel power at RF Input, plus any external attenuation, excluding mismatch error)		
Cellular Bands		
30 to -5 dBm 20 to 30 °C	±0.80 dB	±0.36 dB, typical
0 to 55 °C	±1.13 dB	
-5 to -25 dBm 20 to 30 °C	±0.77 dB	±0.33 dB, typical
0 to 55 °C	±1.10 dB	
-25 to -45 dBm 20 to 30 °C	±0.65 dB	±0.29 dB, typical
0 to 55 °C	±1.00 dB	
-45 to -55 dBm 20 to 30 °C	±0.72 dB	±0.36 dB, typical
0 to 55 °C	±1.01 dB	
-55 to -70 dBm 20 to 30 °C	±0.86 dB	±0.47 dB, typical
0 to 55 °C	±1.28 dB	
PCS Bands		
30 to -5 dBm 20 to 30 °C	±0.70 dB	±0.29 dB, typical
0 to 55 °C	±1.15 dB	
-5 to -25 dBm 20 to 30 °C	±0.67 dB	±0.26 dB, typical
0 to 55 °C	±1.11 dB	
-25 to -45 dBm 20 to 30 °C	±0.66 dB	±0.27 dB, typical
0 to 55 °C	±0.97 dB	
-45 to -55 dBm 20 to 30 °C	±0.73 dB	±0.34 dB, typical

	Specifications	Supplemental Information
0 to 55 °C	±0.98 dB	±0.45 dB, typical
-55 to -70 dBm 20 to 30 °C	±0.87 dB	
0 to 55 °C	±1.25 dB	

	Specifications	Supplemental Information
Channel power relative power accuracy (same channel, different Tx power, input attenuator fixed, RF input range manual).	See Display Scale Fidelity	

	Specifications	Supplemental Information
Receive Channel Power		
Absolute Power Accuracy		
Cellular bands		
30 to 0 dBm	±0.98 dB	±0.55 dB, typical
0 to -85 dBm	±2.02 dB	±1.33 dB, typical
PCS bands		
30 to 0 dB	±1.00 dB	±0.60 dB, typical
0 to -85 dBm	±1.52 dB	±0.84 dB, typical
Preamp (<i>Option 1DS</i>)		
Cellular and PCS bands		
30 to -80 dBm	±2.45 dB	±1.70 dB, typical
-80 to -100 dBm	±3.20 dB	±2.30 dB, typical

	Specifications	Supplemental Information
Occupied Bandwidth		
Carrier power range	30 to -45 dBm	
Frequency resolution of occupied BW	1.88 kHz	
Frequency accuracy of occupied BW (1.23 MHz channel BW)		±15 kHz, characteristic
Frequency resolution of delta frequency	3.75 kHz	

	Specifications	Supplemental Information
Frequency accuracy of delta frequency		$\pm (35 \text{ kHz} + \text{frequency reference error} \times \text{carrier frequency})$, characteristic

	Specifications	Supplemental Information
Code Domain Power (Requires <i>Options 1D5, B7D, and B7E</i> . Measurement interval ≥ 1.25 ms unless otherwise noted.)		
Carrier power range at RF Input (Pilot channel power > -11 dBc)	30 to -13 dBm	30 to -65 dBm ^a , characteristic
Preamp (<i>Option 1DS</i>)	30 to -30 dBm	30 to -82 dBm ^a , characteristic
Measurement interval range	0.5 ms to 26.67 ms	
Code domain power		
Display dynamic range	50 dB	
Accuracy (Walsh channel power within 20 dB of total power)		± 0.2 dB, typical
Displayed resolution	0.01 dB	
Other reported power parameters (dB referenced to total power)		Average active traffic, maximum inactive traffic, average inactive traffic, pilot, paging, sync channels
Carrier frequency error (Measurement interval ≥ 2.5 ms)		Excludes frequency reference error.
Input frequency error range	± 100 kHz	± 200 kHz, typical
Accuracy	± 10 Hz	± 7 Hz, typical
Displayed resolution	Four digits	
Estimated Rho		
Range	0.9 to 1.0	0.5 to 1.0 ^b
Accuracy (With 9 channels active over the specified range) ^c		± 0.02 , characteristic
Displayed resolution	0.0001	

	Specifications	Supplemental Information
Pilot time offset		From even second signal to start of PN sequence
Range	–13.33 ms to +13.33 ms	
Accuracy	±150 ns	
Displayed resolution	Four digits	
Code domain timing		Pilot to code channel time tolerance
Range	±200 ns	
Accuracy (IS-97A nominal power levels) ^d		±7 ns, typical
Code domain phase		Pilot to code channel phase tolerance
Range	±200 mrad	
Accuracy (IS-97A nominal power levels) ^d		±10 mrad, typical
Displays		Power Graph and Metrics, or Power, Timing, and Phase Graphs

- a. Performance may degrade outside of the specified carrier power range at RF input listed in the specifications column.
- b. Performance may degrade outside of the estimated rho range listed in the specifications column.
- c. The Active Set Threshold is less than all active channels, but greater than –20 dBc.
- d. IS-97A nominal base station test model levels (fraction of carrier power); Pilot: 0.20 (–7.0 dBc), Sync: 0.0471 (–13.3 dBc), Paging: 0.1882 (–7.3 dBc), 6 Traffic channels: 0.09412 (–10.3 dBc)

	Specifications	Supplemental Information
Modulation Accuracy (Rho) (Requires <i>Options 1D5, B7D, and B7E</i> . Measurement interval ≥1.25 ms unless otherwise noted.)		
Carrier power range at RF Input	30 to –28 dBm	30 to –70 dBm ^a , characteristic
Preamp (<i>Option 1DS</i>)	30 to –45 dBm	30 to –87 dBm ^a , characteristic
Measurement interval range	0.15 ms to 26.67 ms	
Rho (waveform quality)		
Range	0.9 to 1.0	0.5 to 1.0 ^b , characteristic
Accuracy		±0.0016, typical
Displayed resolution	0.0001	

	Specifications	Supplemental Information
Carrier frequency error (Measurement interval ≥ 2.5 ms)		Excludes frequency reference error
Input frequency error range	± 100 kHz	± 200 kHz, typical
Accuracy	± 10 Hz	± 7 Hz, typical
Displayed resolution	Four digits	
Pilot time offset		From even second signal to start of PN sequence
Range	-13.33 ms to +13.33 ms	
Accuracy	± 150 ns	
Displayed resolution	Four digits	
EVM		
Floor		3.8%, typical
Accuracy ^c		$\pm 1.1\%$, typical
Displayed Resolution	0.01%	
Carrier feedthrough		
Floor		-51 dBc, typical
Accuracy (Carrier feedthrough ≥ -43 dBc)		± 2.3 dB, typical
Displayed resolution	0.01 dB	
Magnitude error		
Floor		3.8%, typical
Accuracy ^c		$\pm 1.1\%$, typical
Displayed resolution	0.01%	
Phase error		
Accuracy ^c		± 0.65 degrees, typical
Displayed resolution	0.01 degrees	
Displays		Numeric results or Numeric results and IQ graph

- a. Performance may degrade outside of the specified carrier power range at RF input listed in the specifications column.
- b. Performance may degrade outside of the rho range listed in the specifications column.
- c. Accuracy does not include the effects of the EVM floor. The measurement variance increases as the result approaches the EVM floor.

	Specifications	Supplemental Information
Spur Close (In Band)		
Carrier power range at RF Input	30 to -12 dBm	
Dynamic range		
Input power		
30 to 25 dBm	55 dB	
25 to 20 dBm	50 dB	
20 to -12 dBm	46 dB	
Relative accuracy	$\pm(2.7 \text{ dB} + 0.01 \times (\text{dB from reference level}))$	$\pm(0.3 \text{ dB} + 0.01 \times (\text{dB from reference level}))$, typical
Displayed resolution	0.01 dB	

	Specifications	Supplemental Information
Out-of-Band Spurious^a		Refer to the Amplitude specifications section in this guide.

a. The out-of-band measurement is made with the user-defined tables with 20 frequency ranges each (up to the top 10 spurs per range, 100 spurs maximum). Table parameters include frequency range, RBW, video BW, detector type, and amplitude test limits.

	Specifications	Supplemental Information
Receiver Spurious Emissions		
Spurious emission power range	-20 to -83 dBm	
Preamp On (<i>Option IDS</i>)	-40 to -101 dBm	
Absolute spurious emission power accuracy		
-20 to -60 dBm	$\pm 2.6 \text{ dB}$	$\pm 1.7 \text{ dB}$, typical
-60 to -83 dBm	$\pm 4.3 \text{ dB}$	$\pm 3.4 \text{ dB}$, typical
Preamp On (<i>Option IDS</i>)		
-40 to -70 dBm	$\pm 3.6 \text{ dB}$	$\pm 2.6 \text{ dB}$, typical
-70 to -101 dBm	$\pm 5.0 \text{ dB}$	$\pm 3.9 \text{ dB}$, typical

	Specifications	Supplemental Information
External Correction External attenuation, external gain Range Resolution	-90 to 90 dB 0.01 dB	

	Specifications	Supplemental Information
Trigger Trigger source (Actual available choices dependent on measurement) (Option B7D and B7E) Delay trigger Range Resolution RF burst trigger level (Option B7E) Trigger slope (External and RF burst) Frame timing period Frame synchronizing source Frame synchronizing slope	Free run, external Add RF Burst, frame 0 to 500 ms 300 ns 0 to -25 dBc Positive/Negative 50 ns to 13.6533 s External frame sync Positive/Negative	 Rear panel connector labelled EXT FRAME SYNC (Option B7D)

	Specifications	Supplemental Information
Demod Trigger Source Even second input (Frame trigger only, Option B7D and B7E) PN offset range	 0 to 511 x 64 [chips]	 Rear panel connector labelled EXT FRAME SYNC

GSM Measurement Personality (Option BAH)

Unless otherwise noted, all specifications are with RF input range auto, default GSM measurement settings, and in the in-band frequency range. *Option 1D6* and *Option B72* are required.

	Specifications	Supplemental Information
In-Band Frequency Range		
GSM 900, P-GSM bands	890 to 915 MHz 935 to 960 MHz	
GSM 900, E-GSM bands	880 to 915 MHz 925 to 960 MHz	
GSM 900, R-GSM bands	876 to 915 MHz 921 to 960 MHz	
DCS 1800 bands	1710 to 1785 MHz 1805 to 1880 MHz	
PCS 1900 bands	1850 to 1910 MHz 1930 to 1990 MHz	

	Specifications	Supplemental Information
Transmitter Power (Requires <i>Option B7D</i> or <i>AYX</i>)		
Range at RF Input	30 to -60 dBm	
Absolute power accuracy for in-band signal (Mean channel power at RF Input, plus any external attenuation, excluding mismatch error)		
P-GSM, E-GSM, and R-GSM Bands		
30 to -20 dBm 20 to 30 °C	±0.89 dB	±0.39 dB, typical
0 to 55 °C	±1.65 dB	
-20 to -30 dBm 20 to 30 °C	±0.82 dB	±0.38 dB, typical
0 to 55 °C	±1.48 dB	

	Specifications	Supplemental Information
-30 to -40 dBm 20 to 30 °C	±0.87 dB	±0.39 dB, typical
0 to 55 °C	±1.47 dB	
-40 to -50 dBm 20 to 30 °C	±1.06 dB	±0.57 dB, typical
0 to 55 °C	±1.60 dB	
-50 to -60 dBm 20 to 30 °C	±1.19 dB	±0.70 dB, typical
0 to 55 °C	±1.71 dB	
DCS 1800 and PCS 1900 Bands		
30 to -20 dBm 20 to 30 °C	±0.76 dB ^a	±0.28 dB ^a , typical
0 to 55 °C	±1.26 dB ^a	
-20 to -30 dBm 20 to 30 °C	±0.66 dB ^a	±0.27 dB ^a , typical
0 to 55 °C	±1.06 dB ^a	
-30 to -40 dBm 20 to 30 °C	±0.71 dB ^a	±0.26 dB ^a , typical
0 to 55 °C	±1.00 dB ^a	
-40 to -50 dBm 20 to 30 °C	±0.90 dB ^a	±0.44 dB ^a , typical
0 to 55 °C	±1.13 dB ^a	
-50 to -60 dBm 20 to 30 °C	±1.03 dB ^a	±0.57 dB ^a , typical
0 to 55 °C	±1.24 dB ^a	

a. For Option UKB, add 0.10 dB.

	Specifications	Supplemental Information
Transmitter Power (Requires <i>Option B7D</i> or <i>AYX</i>)		
Range at RF Input	30 to -60 dBm	

	Specifications	Supplemental Information
Absolute power accuracy for in-band signal		
(Mean channel power at RF Input, plus any external attenuation, excluding mismatch error)		
P-GSM, E-GSM, and R-GSM Bands		
30 to -20 dBm 20 to 30 °C	±0.81 dB	±0.38 dB, typical
0 to 55 °C	±1.31 dB	
-20 to -30 dBm 20 to 30 °C	±0.74 dB	±0.37 dB, typical
0 to 55 °C	±1.14 dB	
-30 to -40 dBm 20 to 30 °C	±0.79 dB	±0.37 dB, typical
0 to 55 °C	±1.11 dB	
-40 to -50 dBm 20 to 30 °C	±0.95 dB	±0.53 dB, typical
0 to 55 °C	±1.21 dB	
-50 to -60 dBm 20 to 30 °C	±1.09 dB	±0.66 dB, typical
0 to 55 °C	±1.33 dB	
DCS 1800 and PCS 1900 Bands		
30 to -20 dBm 20 to 30 °C	±0.68 dB	±0.28 dB, typical
0 to 55 °C	±1.30 dB	
-20 to -30 dBm 20 to 30 °C	±0.61 dB	±0.27 dB, typical
0 to 55 °C	±1.12 dB	
-30 to -40 dBm 20 to 30 °C	±0.66 dB	±0.27 dB, typical
0 to 55 °C	±0.99 dB	
-40 to -50 dBm 20 to 30 °C	±0.82 dB	±0.43 dB, typical
0 to 55 °C	±1.09 dB	

	Specifications	Supplemental Information
-50 to -60 dBm 20 to 30 °C	±0.96 dB	±0.56 dB, typical
0 to 55 °C	±1.21 dB	

	Specifications	Supplemental Information
Transmitter Power Relative Power Accuracy (same channel, different Tx power, input attenuator fixed, RF input range manual).	See Display Scale Fidelity	

	Specifications	Supplemental Information
Power versus Time (Requires <i>Option B7D</i> or <i>AYX</i>)		
Carrier power range at RF Input	30 to -23 dBm	30 to -55 dBm ^a , characteristic
Preamplifier On (<i>Option 1DS</i>)	30 to -40 dBm	30 to -72 dBm ^a , characteristic
Time resolution accuracy		±1% of sweep time, characteristic
Maximum record length	8 time slots	
Burst to mask uncertainty (Requires <i>Option B7D</i> and <i>B7E</i>)	±1.0 bit	

a. Performance may degrade outside of the specified carrier power range at RF input listed in the specifications column.

	Specifications	Supplemental Information
Output RF Spectrum		
Carrier power range at RF Input		
Offsets ≤1800 kHz, 30 kHz RBW		30 to -5 dBm, characteristic
Offsets >1800 kHz, 100 kHz RBW		30 to -4 dBm, characteristic
Reference power accuracy	Same as Transmitter Power measurement	
Relative accuracy ^a	See Display Scale Fidelity	

	Specifications	Supplemental Information
Spectrum due to modulation displayed dynamic range ^{b,c}		
100 kHz offset		30 dB, characteristic
200 kHz offset		60 dB, characteristic
250 kHz offset		60 dB, characteristic
400 kHz offset		70 dB, characteristic
600 kHz to 1.8 MHz offset		79 dB, characteristic
1.8 to 6.0 MHz offset		75 dB, characteristic
> 6 MHz offset		76 dB, characteristic
Swept Mode Dynamic Range		70 dB, characteristic
Spectrum due to switching transients displayed dynamic range ^{b,c}		
400 kHz offset		62 dB, characteristic
600 kHz offset		79 dB, characteristic
1200 kHz offset		79 dB, characteristic
1800 kHz offset		80 dB, characteristic
Swept Mode Dynamic Range		70 dB, characteristic

- a. Does not include uncertainty due to noise.
- b. Displayed dynamic range for specific frequency offsets—applies to CW signal at the specified offset. Dynamic range with a GSM signal may differ.
- c. Using default settings, the RBW filter has a corrected noise BW and impulse BW equivalent to five-pole synchronously tuned filter.

	Specifications	Supplemental Information
Phase and Frequency Error (Requires <i>Option 1D5, B7D, and B7E</i>)		
Carrier power range at RF Input	30 to -23 dBm	30 to -55 dBm ^a , characteristic
Preamplifier On (<i>Option 1DS</i>)	30 to -40 dBm	30 to -72 dBm ^a , characteristic
Phase error		
Range	0 to 180°	
Displayed resolution	0.01°	
Accuracy (Averages ≥10)		
Peak	±2.1°	±1.5°, typical

	Specifications	Supplemental Information
RMS Frequency error	$\pm 1.1^\circ$	$\pm 0.6^\circ$, typical Excludes frequency reference error
Initial frequency error range	± 100 kHz	
Accuracy (Averages ≥ 10)	± 10 Hz	± 5 Hz, typical
I/Q offset range	-10 to -46 dBc	
Burst sync time uncertainty	± 0.1 bit	
Displays		Numeric summary

- a. Performance may degrade outside of the specified carrier power range at RF input listed in the specifications column.

	Specifications	Supplemental Information
Transmit Band Spurious		
Carrier power range at RF Input		30 to -12 dBm, typical
Dynamic range		
Upper and lower adjacent segments		55 dB, characteristic
Upper and lower segments		44 dB, characteristic
Relative accuracy		$\pm(0.3 \text{ dB} + 0.01 \times (\text{dB from reference level}))$, characteristic
Displayed resolution	0.01 dB	

	Specifications	Supplemental Information
Out-of-Band Spurious^a		
Absolute Spurious Power Accuracy		Refer to the Amplitude specifications section in this guide.
Sensitivity ^b		
RBW		
1 kHz		-95 dBm, characteristic
3 kHz		-90 dBm, characteristic
10 kHz		-85 dBm, characteristic
30 kHz		-78 dBm, characteristic
100 kHz		-71 dBm, characteristic
300 kHz		-64 dBm, characteristic

	Specifications	Supplemental Information
1 MHz		-57 dBm, characteristic
3 MHz		-50 dBm, characteristic

- a. The out-of-band spurious measurement is made in accordance with the tables defined in the appropriate GSM specification document. The measurement is made over several frequency ranges (up to 10 spurs per range, 100 spurs maximum).
- b. With input attenuation of 5 dB. For all other attenuation settings, add (input attenuation - 5) dB.

	Specifications	Supplemental Information
Receive Band Spurious		
Spurious emission power range ^a		-20 to -73 dBm, characteristic
Preamp On (<i>Option IDS</i>)		-40 to -91 dBm, characteristic
Absolute spurious emission power accuracy		
-20 to -60 dBm		±1.9 dB, characteristic
-60 to -73 dBm		±2.5 dB, characteristic
Preamp on (<i>Option IDS</i>)		
-40 to -70 dBm		±2.8 dB, characteristic
-70 to -91 dBm		±4.1 dB, characteristic

- a. Requires bandpass filter centered on receive band, peak detector mode, 0 dB attenuation, 100 kHz RBW. Does not include insertion loss of bandpass filter.

	Specifications	Supplemental Information
Amplitude Range Control		RF Input Autorange, Manually set Max Total Pwr Manually set Input Atten

	Specifications	Supplemental Information
External Gain/Attenuation Correction		
Base gain, base attenuation, mobile gain, mobile attenuation		
Range	0 to 81.9 dB	
Resolution	0.01 dB	

	Specifications	Supplemental Information
Trigger		
Trigger source (Actual available choices dependent on measurement) (<i>Option B7D and B7E</i>)	Free run, external Add RF Burst and frame	
RF burst trigger (<i>Option B7E</i>)		
Peak carrier power range ^a	30 to -25 dBm	30 to -30 dBm, typical
Preamp On (<i>Option 1DS</i>)	30 to -45 dBm	30 to -50 dBm, typical
Trigger level range	0 to -25 dB relative to signal peak	

a. With trigger level set to -6 dB.

	Specifications	Supplemental Information
Burst Sync (Requires <i>Option AYX or B7D</i>)		
Source (Actual available choices dependent on measurement) (<i>Option B7D and B7E</i>)	RF amplitude, none Add training sequence	
Training sequence code		GSM defined 0 to 7 Auto (search) or Manual
Burst type		Normal (TCH and CCH) Sync (SCH) Access (RACH)

General

	Specifications	Supplemental Information
Temperature Range		
Operating	0 to 55 °C	Floppy disk 10 to 40 °C
Storage	-40 to 75 °C	

	Specifications	Supplemental Information
Audible Noise (ISO 7779)		
Sound Pressure at 25 °C		<40 dBa, (<4.6 Bels power)

	Specifications	Supplemental Information
Military Specification	Has been type tested to the environmental specifications of MIL-PRF-28800F class 3.	

	Specifications	Supplemental Information
EMI Compatibility	Conducted and radiated emission is in compliance with CISPR Pub. 11/1990 Group 1 Class A.	
<i>(Option 060)^a</i>	Conducted and radiated emission is in compliance with CISPR Pub. 11/1990 Group 1 Class B ^b .	

- a. Option 060 is not compatible with Option B7B nor Option 1DP.
b. Meets Class A performance during dc operation.

	Specifications	Supplemental Information
Immunity Testing		
Radiated Immunity		Testing was done at 3 V/m according to IEC 801-3/1984. When the analyzer tuned frequency is identical to the immunity test signal frequency, there may be signals of up to -60 dBm displayed on the screen.

	Specifications	Supplemental Information
Electrostatic Discharge		Air discharges of up to 8 kV were applied according to IEC 801-2/1991. Discharges to center pins of any of the connectors may cause damage to the associated circuitry.

	Specifications	Supplemental Information
Power Requirements		
ac Operation		
Voltage, frequency	90 to 132 Vrms, 47 to 440 Hz 195 to 250 Vrms, 47 to 66 Hz	
Power Consumption, On	<300 W	
Power Consumption, Standby	<5 W	
dc Operation		
Voltage	12 to 20 Vdc	
Power Consumption	<200 W	
Power Consumption, Standby	<100 mW	

	Specifications	Supplemental Information
Measurement Speed		
Local Measurement and Display Update rate ^a		
Sweep points = 101		≥ 40/s, characteristic
Sweep points = 401		≥ 28/s, characteristic
Remote Measurement and GPIB Transfer Rate ^{b,c}		
(Option A4H)		
Sweep points = 101		≥ 40/s, characteristic
Sweep points =401		≥ 28/s, characteristic

	Specifications	Supplemental Information
RF Center Frequency Tune, Measure, and GPIB Transfer Time ^{b,d} (Option A4H)		
Sweep points = 101		≤ 75 ms, characteristic
Sweep points = 401		≤ 90 ms, characteristic

- Factory preset, auto align Off, segmented sweep Off, fixed center frequency, RBW = 1 MHz, spans >10 MHz and ≤600 MHz, and stop frequency ≤3 GHz.
- Display Off (:DISPlay:ENABLE OFF), and 32-bit integer data format (:FORMat:DATA INT,32), if *Option A4J* or *A4J* is installed, disable sweep ramp, (:SYSem:PORTs:IFVSweep:ENABLE OFF), markers Off, single sweep, measured with IBM compatible PC with 550 MHz Pentium® III running Windows® NT 4.0, one meter GPIB cable, National Instruments PCI-GPIB card and NI-488.2 DLL.
- Factory preset, auto align Off, segmented sweep Off, fixed center frequency, RBW = 1 MHz, and span = 20 MHz, fixed center frequency, stop frequency ≤3 GHz, average of 100 measurements.
- Factory preset, auto align Off, segmented sweep Off, RBW = 1 MHz, span= 20 MHz, stop frequency ≤3 GHz, center frequency tune step size = 50 MHz.

	Specifications	Supplemental Information
Data Storage		
Internal		200 Traces or States ^a
External (10 to 40 °C) 3.5" 1.44 MB, MS-DOS® compatible floppy disk		200 Traces or States ^a

- When storing traces set to 401 points.

	Specifications	Supplemental Information
Downloadable Program Memory <i>(Option B72)</i>		2 MB available memory 10 MB available memory

	Specifications	Supplemental Information
Demod Tune and Listen		
Demod <i>(Option BAA or 106)</i> <i>(Option A4J or A4YX)</i>	AM Add FM	Internal speaker, front-panel earphone jack and front-panel volume control. An uncalibrated demodulated signal is available on the AUX VIDEO OUT connector at the rear panel.

	Specifications	Supplemental Information
<i>(Option 106 or BAA)</i>		An uncalibrated demodulated signal is available on the EXT VIDEO OUT connector at the rear panel.

	Specifications	Supplemental Information
Weight (without options)		
Net		17.1 kg (37.7 lb), characteristic
Shipping		31.9 kg (70.3 lb), characteristic

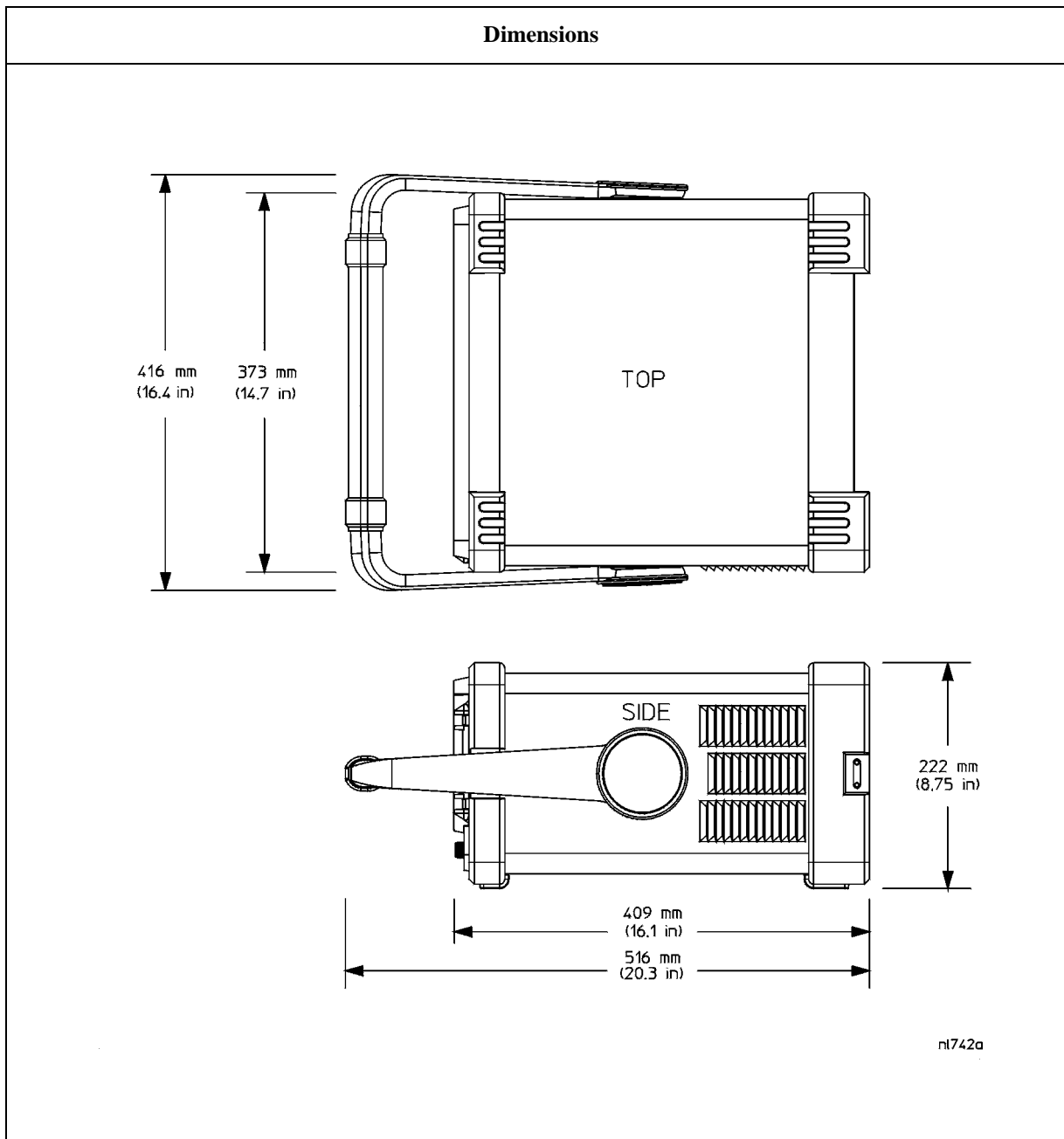

Inputs and Outputs

Front Panel

	Specifications	Supplemental Information
INPUT 50 Ω		
Connector	Type-N female	
Impedance		50 Ω, nominal

	Specifications	Supplemental Information
RF OUT 50 Ω, (Option 1DN)		
Connector	Type-N female	
Impedance		50 Ω, nominal

	Specifications	Supplemental Information
AMPTD REF OUT^a		Amplitude Reference
Connector	BNC female	
Impedance		50 Ω, nominal
Frequency		50 MHz
Frequency Accuracy		Frequency reference error ^b
50 Ω Amplitude ^c		-20 dBm, nominal

- Turn the amplitude reference on/off by pressing the keys: **Input/Output, Amptd Ref Out**.
- Frequency reference error = (aging rate × period of time since adjustment + settability + temperature stability).
- The internal amplitude reference actual power is stored internally.

	Specifications	Supplemental Information
PROBE POWER		
Voltage/Current		+15 Vdc, ±7% at 150 mA max., characteristic -12.6 Vdc ±10% at 150 mA max., characteristic

	Specifications	Supplemental Information
EXT KEYBOARD^a		Used for entering screen titles and filenames only. Interface compatible with most IBM-compatible PC keyboards.
Connector	6-pin mini-DIN	

a. The feature is not implemented in firmware revisions prior to A.04.00.

	Specifications	Supplemental Information
Speaker		Front panel knob controls volume

	Specifications	Supplemental Information
Headphone		Front panel knob controls volume
Connector	3.5 mm (1/8 inch) miniature audio jack	
Power Output		0.2 W into 4 Ω , characteristic

Rear Panel

	Specifications	Supplemental Information
10 MHz REF OUT		
Connector	BNC female	
Impedance		50 Ω , nominal
Output Amplitude		>0 dBm, characteristic

	Specifications	Supplemental Information
10 MHz REF IN		
Connector	BNC female	Note: Analyzer noise sidebands and spurious response performance may be affected by the quality of the external reference used.
Impedance		50 Ω , nominal
Input Amplitude Range		-15 to +10 dBm, characteristic
Frequency		10 MHz, nominal

	Specifications	Supplemental Information
EXT REF IN (Option B7E)		
Connector	BNC, female	
Impedance		50 Ω, nominal
Input amplitude range	-5 to 10 dBm	
Frequency	1 to 30 MHz, selectable	
Frequency lock range	$\pm 5 \times 10^{-6}$ of specified external reference input frequency	

	Specifications	Supplemental Information
10 MHz OUT (Option B7E)		
Connector	BNC, female	
Impedance		50 Ω, nominal
Frequency		10 MHz, nominal
Level		0 dBm when Option 10 MHz Out is On

	Specifications	Supplemental Information
GATE TRIG/EXT TRIG IN		
Connector	BNC female	
External Trigger Input		
Trigger Level		Selectable positive or negative edge initiates sweep in EXT TRIG mode (5 V TTL)
Gate Trigger Input (Option 1D6)		
Minimum Pulse Width		>30 ns (5 V TTL)

	Specifications	Supplemental Information
GATE/HI SWP OUT		
Connector	BNC female	
High Sweep Output Level		High = sweep ^a ; Low = retrace (5 V TTL)
Gate Output (<i>Option 1D6</i>) Level		High = gate on; Low = gate off (5 V TTL)

a. High sweep may be high longer than the indicated sweep times.

	Specifications	Supplemental Information
VGA OUTPUT		
Connector	VGA compatible, 15-pin mini D-SUB	
Format		VGA (31.5 kHz horizontal, 60 Hz vertical sync rates, non-interlaced) Analog RGB
Resolution	640 × 480	

	Specifications	Supplemental Information
AUX IF OUT (<i>Option A4J or AYX</i>)		
Connector	BNC female	RBW ≥ 1 kHz
Frequency		21.4 MHz, nominal
Amplitude (for signal at reference level and for reference levels – input attenuation + preamp gain of –10 to –70 dBm)		–10 dBm (uncorrected), characteristic
Impedance		50 Ω, nominal

	Specifications	Supplemental Information
AUX VIDEO OUT (Option A4J or AYZ)		RBW \geq 1 kHz
Connector	BNC female	
Amplitude Range (into >10 k Ω)		0 to 1 V (uncorrected), characteristic

	Specifications	Supplemental Information
HI SWP IN (Option A4J or AYZ)		
Connector	BNC female	
Input		Open collector, low resets and holds the sweep (5 V TTL)

	Specifications	Supplemental Information
HI SWP OUT (Option A4J or AYZ)		
Connector	BNC female	
Output		High = sweep ^a , Low = retrace (5 V TTL)

a. High sweep may be high longer than the indicated sweep times.

	Specifications	Supplemental Information
SWP OUT (Option A4J or AYZ)		
Connector	BNC female	
Amplitude		0 to +10 V ramp, characteristic

	Specifications	Supplemental Information
PRESEL TUNE OUTPUT		
Connector	BNC female	
Load Impedance (dc coupled)		> 10 k Ω , nominal
Range		0 to +10 V, characteristic
Sensitivity		0.33 V/GHz of tuned frequency > 3 GHz, characteristic

Agilent E4404B Specifications and Characteristics
Inputs and Outputs

	Specifications	Supplemental Information
GPIB Interface (<i>Option A4H</i>)		
Connector	IEEE-488 bus connector	
GPIB Codes		SH1, AH1, T6, SR1, RL1, PP0, DC1, C1, C2, C3 and C28

	Specifications	Supplemental Information
Serial Interface (<i>Option IAX</i>)		
Connector	9-pin D-SUB male	RS-232

	Specifications	Supplemental Information
Parallel Interface (<i>Option A4H or IAX</i>)		
Connector	25-pin D-SUB female	Printer port only

	Specifications	Supplemental Information
EXT VIDEO IN/TV TRIG OUT ^a (<i>Option B7B or BAA</i>)		
Connector	BNC Female (75 Ω)	EXT VIDEO IN is the Baseband composite video input for TV trigger and picture on screen. TV TRIG OUT is the TV trigger output.
Impedance		75 Ω, nominal
(<i>Option BAA without Option B7B</i>)		Feature not implemented
(<i>Option BAA with Option B7B</i>)		
External Video Input Video Amplitude		1 V _{p-p} , nominal, characteristic
TV Trigger Output		Positive edge indicates start of selected TV line after sync. pulse
Amplitude		TTL (0 V and 3.4 V with 75 Ω series resistance), characteristic

- a. This connector is labelled EXT VIDEO IN on older spectrum analyzers and EXT VIDEO IN/TV TRIG OUT on newer spectrum analyzers.

	Specifications	Supplemental Information
EXT VIDEO OUT <i>(Option B7B or BAA)</i> Connector Impedance <i>(Option BAA without Option B7B)</i> Amplitude <i>(Option BAA with Option B7B)</i> Amplitude TV Source: SA TV Source and EXT VIDEO IN <i>(Option 106)</i> Connector Impedance Amplitude	BNC female (75 Ω) BNC female (75 Ω)	Baseband video output RBW ≥ 1 kHz 75 Ω, nominal 0 to 1 V (uncorrected), characteristic 0 to 1 V (uncorrected), characteristic Same as level at EXT VIDEO IN/TV TRIG OUT, characteristic 75 Ω, nominal 0 to 1 V (uncorrected), characteristic

	Specifications	Supplemental Information
EXT FRAME SYNC <i>(Option B7D)</i> Connector Level	BNC, female	5 V TTL

Regulatory Information

CAUTION

This product is designed for use in Installation Category II and Pollution Degree 2 per IEC 1010 and 664 respectively.

NOTE

This product has been designed and tested in accordance with IEC Publication 1010, Safety Requirements for Electronic Measuring Apparatus, and has been supplied in a safe condition. The instruction documentation contains information and warnings which must be followed by the user to ensure safe operation and to maintain the product in a safe condition.



The CE mark is a registered trademark of the European Community (if accompanied by a year, it is the year when the design was proven).



The CSA mark is the Canadian Standards Association safety mark.

ISM 1-A

This is a symbol of an Industrial Scientific and Medical Group 1 Class A product. (CISPR 11, Clause 4)

Declaration of Conformity

DECLARATION OF CONFORMITY	
According to ISO/IEC Guide 22 and CEN/CENELEC EN 45014	
Manufacturer's Name:	Agilent Technologies, Inc.
Manufacturer's Address:	1400 Fountaingrove Parkway Santa Rosa, CA 95403-1799 USA
Declares that the products	
Product Name:	Spectrum Analyzer
Model Number:	E4401B, E4402B, E4403B, E4404B, E4405B, E4407B, E4408B, E4411B
Product Options:	This declaration covers all options of the above products.
Conform to the following product specifications:	
EMC: IEC 61326-1:1997+A1:1998 / EN 61326-1:1997+A1:1998	
<u>Standard</u>	<u>Limit</u>
CISPR 11:1990 / EN 55011-1991	Group 1, Class A
IEC 61000-4-2:1995+A1998 / EN 61000-4-2:1995	4 kV CD, 8 kV AD
IEC 61000-4-3:1995 / EN 61000-4-3:1995	3 V/m, 80 - 1000 MHz
IEC 61000-4-4:1995 / EN 61000-4-4:1995	0.5 kV sig., 1 kV power
IEC 61000-4-5:1995 / EN 61000-4-5:1996	0.5 kV L-L, 1 kV L-G
IEC 61000-4-6:1996 / EN 61000-4-6:1998	3 V, 0.15 – 80 MHz
IEC 61000-4-11:1994 / EN 61000-4-11:1998	1 cycle, 100%
Safety: IEC 61010-1:1990 + A1:1992 + A2:1995 / EN 61010-1:1993 +A2:1995 CAN/CSA-C22.2 No. 1010.1-92	
Supplementary Information: The products herewith comply with the requirements of the Low Voltage Directive 73/23/EEC and the EMC Directive 89/336/EEC and carry the CE-marking accordingly.	
	
Santa Rosa, CA, USA	17 April 2000
Greg Pfeiffer/Quality Engineering Manager	
For further information, please contact your local Agilent Technologies sales office, agent or distributor.	

4 **Agilent E4405B Specifications and Characteristics**

About This Chapter

This chapter contains specifications and characteristics for the Agilent E4405B spectrum analyzer. The distinction between specifications and characteristics is described as follows.

- Specifications describe the performance of parameters covered by the product warranty. (The temperature range is 0 °C to 55 °C, unless otherwise noted.)
- Characteristics describe product performance that is useful in the application of the product, but is not covered by the product warranty.
- Typical performance describes additional product performance information that is not covered by the product warranty. It is performance beyond specification that 80% of the units exhibit with a 95% confidence level over the temperature range 20 to 30 °C. Typical performance does not include measurement uncertainty.
- Nominal values indicate the expected performance, or describe product performance that is useful in the application of the product, but is not covered by the product warranty.

The following conditions must be met for the analyzer to meet its specifications.

- o The analyzer is within the one year calibration cycle.
- o If **Auto Align All** is selected:
 - After 2 hours of storage within the operating temperature range.
 - 5 minutes after the analyzer is turned on with sweep times less than 4 seconds.
 - After the front-panel amplitude reference is connected to the INPUT, and **Align Now RF** has been run, after the analyzer is turned on. And, once every 24 hours, or if ambient temperature changes more than 30 °C¹.
- o If **Auto Align Off** is selected:
 - When the analyzer is at a constant temperature, within the operating temperature range, for a minimum of 90 minutes.
 - After the analyzer is turned on for a minimum of 90 minutes, the front panel amplitude reference has been connected to the INPUT, and **Align Now All** has been run.
 - When **Align Now All** is run:
 - Every hour
 - If the ambient temperature changes more than 3 °C

1. 10 °C if Preamp (*Option IDS*) is active.

- If the 10 MHz reference changes
- When **Align Now RF** is run (with the front-panel amplitude reference connected to the INPUT):
 - Every 24 hours
 - If the ambient temperature changes more than 30 °C¹
- o If **Auto Align All but RF** is selected:
 - When the analyzer is at a constant temperature, within the operating temperature range, for a minimum of 90 minutes.
 - After the analyzer is turned on for a minimum of 90 minutes, the front panel amplitude reference has been connected to the INPUT, and **Align Now RF** has been run.
 - When **Align Now RF** is run (with the front-panel amplitude reference connected to the INPUT):
 - Every hour
 - If the ambient temperature changes more than 3 °C

1. 10 °C if Preamp (*Option 1DS*) is active.

Frequency

	Specifications	Supplemental Information
Frequency Range		
dc Coupled	9 kHz to 13.2 GHz	30 Hz to 13.2 GHz, characteristic
(<i>Option UKB</i>)	100 Hz to 13.2 GHz	
ac Coupled	100 kHz to 13.2 GHz	
Band		Harmonic Mixing Mode (N ^a)
0 (0 Hz to 3.0 GHz)		1–
1 (2.85 GHz to 6.7 GHz)		1–
2 (6.2 GHz to 13.2 GHz)		2–
Preamp On (<i>Option IDS</i>)	1 MHz to 3.0 GHz	

- a. N is the harmonic mixing mode. For negative mixing modes (as indicated by the “–”), the desired 1st LO harmonic is higher than the tuned frequency by the 1st IF (3.9214 for the 9 kHz to 3 GHz band, 321.4 MHz for all other bands).

	Specifications	Supplemental Information
Frequency Reference		
Aging Rate	$\pm 2 \times 10^{-6}$ /year	$\pm 1.0 \times 10^{-7}$ /day, characteristic
Settability	$\pm 5 \times 10^{-7}$	
Temperature Stability	$\pm 5 \times 10^{-6}$	

	Specifications	Supplemental Information
High Stability Frequency Reference (<i>Option ID5</i>)		
Aging Rate	$\pm 1 \times 10^{-7}$ /year	$\pm 5 \times 10^{-10}$ /day, 7-day average after being powered on for 7 days, characteristic
Settability	$\pm 1 \times 10^{-8}$	
Temperature Stability		
20 to 30 °C	$\pm 1 \times 10^{-8}$	
0 to 55 °C	$\pm 5 \times 10^{-8}$	

	Specifications	Supplemental Information
Warm-up (Internal frequency reference selected)		
After 5 minutes		$< \pm 1 \times 10^{-7}$ of final frequency, ^a characteristic
After 15 minutes		$< \pm 1 \times 10^{-8}$ of final frequency, ^a characteristic

a. Final frequency is defined as frequency 60 minutes after power-on with analyzer set to internal frequency reference.

	Specifications	Supplemental Information
Frequency Readout Accuracy (Start, Stop, Center, Marker)	$\pm((\text{frequency indication} \times \text{frequency reference error}^{\text{a}})$ $+ 0.5\% \text{ of span}$ $+ \frac{\text{span}}{\text{sweep points} - 1}$ $+ 15\% \text{ of RBW}$ $+ 10 \text{ Hz} + 1 \text{ Hz} \times N^{\text{b}})$	

a. Frequency reference error = (aging rate \times period of time since adjustment + settability + temperature stability).

b. N is the harmonic mixing mode.

	Specifications	Supplemental Information
Marker Frequency Counter		
Resolution	Selectable from 1 Hz to 100 kHz	
Accuracy ^a	$\pm(\text{marker frequency} \times \text{frequency reference error}^{\text{b}} + \text{counter resolution})^{\text{c}}$	For $\text{RBW} \geq 1 \text{ kHz}$

a. Marker level to displayed noise level $> 25 \text{ dB}$, $\text{RBW}/\text{Span} \geq 0.002$, frequency offset = 0 Hz.

b. Frequency reference error = (aging rate \times period of time since adjustment + settability + temperature stability).

c. For firmware revisions prior to A.03.00, add $1 \text{ Hz} \times N$, where N is the harmonic mixing mode.

	Specifications	Supplemental Information
Frequency Span		
Range	0 Hz (zero span), 100 Hz to 13.2 GHz	
Resolution	2 Hz x N ^a	
Accuracy ^b	±(0.5% of span + 2 × $\frac{\text{span}}{\text{sweep points} - 1}$)	

- a. N is the harmonic mixing mode.
b. Applies to each sweep segment.

	Specifications	Supplemental Information
Sweep Time		
Range		
Span > 0 Hz	1 ms to 4000 s ^a	$\frac{\text{sweep points} - 1}{100 \text{ kHz}}$ to 4000 s
Span = 0 Hz	10 μs to 4000 s ^{a,b}	
Tracking Generator On (Option 1DN)		50 ms is the minimum sweep time
Fast Time-domain Sweep (Option AYX) (For Span = 0 Hz, RBW ≥ 1 kHz)	50 ns to 4000 s ^{c,d}	$\frac{\text{sweep points} - 1}{20 \text{ MHz}}$ to 4000 s
DSP and fast ADC (Option B7D) (For Span = 0 Hz, RBW ≥ 1 kHz)	25 ns to 4000 s ^e	$\frac{\text{sweep points} - 1}{40 \text{ MHz}}$ to 4000 s
Accuracy (Span = 0 Hz)		
10 μs to 4000 s ^{a,b} (Option AYX)	±1%	
50 ns to 4000 s ^{c,d} (Option B7D)	±1%	
25 ns to 4000 s ^e	±1%	
Sweep Trigger ^{f,g} (Option 1D6)	Free Run, Single, Line, Video ^h , External, Delayed, Offset ⁱ	
(Option B7B)	Add Gate Add TV	

	Specifications	Supplemental Information
Delayed Trigger ^{g,j}		
Range	1 μs to 400 s	
Resolution	$\frac{\text{delay in seconds}}{65000}$ rounded up to nearest μs	
Accuracy	±(500 ns + (0.01% of delay))	
Offset Trigger ⁱ		
Resolution	$\frac{\text{sweep time}}{\text{sweep points} - 1}$	
Range	±327 ms to ±12.3 ks	Where ST = sweep time and SP = sweep points $\frac{-32766 \times ST}{SP - 1}$ to $\frac{(32766 - SP) \times ST}{SP - 1}$
Fast Time-domain sweep (Option AYX) (For sweep times $\frac{\text{sweep points} - 1}{20 \text{ MHz}}$ to $\frac{\text{sweep points} - 1}{100 \text{ kHz}}$)	±1.23 ms to ±245 ms	$\frac{-32766 \times ST}{SP - 1}$ to $\frac{(32766 - SP) \times ST}{SP - 1}$
DSP and fast ADC (Option B7D) (For sweep times $\frac{\text{sweep points} - 1}{40 \text{ MHz}}$ to $\frac{\text{sweep points} - 1}{100 \text{ kHz}}$)	±13 ms to ±5.15 s	$\frac{-524031 \times ST}{SP - 1}$ to $\frac{(524031 - SP) \times ST}{SP - 1}$

- For firmware revisions prior to A.04.00, 5 ms to 2000 s.
- For firmware revisions prior to A.05.00, 1 ms to 4000 s.
- For firmware revisions prior to A.04.00, 20 μs to 2000 s.
- For firmware revisions prior to A.05.00, 5 μs to 4000 s.
- For firmware revisions prior to A.05.00, 2.5 μs to 4000 s.
- Gate cannot be used simultaneously with delayed or TV trigger (Option B7B).
- Auto align is suspended in video, external, gate, and delayed trigger modes while waiting for a trigger event to occur.
- Unavailable when RBW ≤ 300 Hz (Option IDR).
- For firmware revision A.04.00 or later.
- Delayed trigger is available with line, external trigger, and TV trigger (Option B7B).

	Specifications	Supplemental Information
Sweep (trace) Points		
Range		
Span > 0 Hz	101 to 8192 ^a	
Span = 0 Hz	2 to 8192 ^{a,b}	

- a. For firmware revisions prior to A.04.00, 401 points.
b. For firmware revisions prior to A.05.00, 101 to 8192 points.

	Specifications	Supplemental Information
Resolution Bandwidth (RBW)		
Range		
-3 dB bandwidth	1 kHz to 3 MHz, in 1-3-10 sequence, 5 MHz	
-6 dB bandwidth (EMI)	9 kHz and 120 kHz	
<i>(Option IDR)</i>		
-3 dB bandwidth	Adds 10, 30, 100, 300 Hz	Only available in spans ≤ 5 MHz, sweep times $\geq \frac{\text{sweep points} - 1}{100 \text{ kHz}}$, and not usable with tracking generator on. <i>(Option IDN)</i>
-6 dB bandwidth (EMI)	Add 200 Hz	
Accuracy		
1 kHz to 3 MHz RBW	±15%	
5 MHz RBW	±30%	
10 Hz to 300 Hz RBW <i>(Option IDR)</i>	±10%	
Shape		
1 kHz to 5 MHz RBW		Synchronously tuned four poles, approximately Gaussian shape
10 Hz to 300 Hz RBW <i>(Option IDR)</i>		Digital, approximately Gaussian shape
Selectivity (60 dB/3 dB bandwidth ratio)		
1 kHz to 5 MHz RBW		<15:1, characteristic
10 Hz to 300 Hz RBW <i>(Option IDR)</i>		<5:1, characteristic

	Specifications	Supplemental Information
Video Bandwidth (VBW) (-3 dB)		
Range	30 Hz to 1 MHz in 1-3-10 sequence	3 MHz, characteristic
(Option 1DR)	Adds 1, 3, 10 Hz for RBW's <1 kHz	
Accuracy		±30%, characteristic
Shape		Post detection, single pole low-pass filter used to average displayed noise
		Video bandwidths below 30 Hz are digital bandwidths with anti-aliasing filtering.

	Specifications	Supplemental Information
Stability		
Noise Sidebands (Offset from CW signal with 1 kHz RBW, 30 Hz VBW and sample detector)		
≥1 kHz (Option 1DR, 1D5)		≤ -78 dBc/Hz ^a , typical
≥10 kHz	≤ -90 dBc/Hz ^a	≤ -94 dBc/Hz ^a , typical
≥20 kHz	≤ -100 dBc/Hz ^a	≤ -105 dBc/Hz ^a , typical
≥30 kHz	≤ -106 dBc/Hz ^a	≤ -112 dBc/Hz ^a , typical
≥100 kHz	≤ -119 dBc/Hz ^a	≤ -122 dBc/Hz ^a , typical
≥1 MHz	≤ -125 dBc/Hz ^a	≤ -127 dBc/Hz ^a , typical
≥5 MHz	≤ -127 dBc/Hz ^a	≤ -129 dBc/Hz ^a , typical
≥10 MHz	≤ -131 dBc/Hz ^a	≤ -136 dBc/Hz ^a , typical
(Option 120)		
≥1 MHz	≤ -133 dBc/Hz ^a	≤ -136 dBc/Hz, typical
≥5 MHz	≤ -135 dBc/Hz ^a	≤ -139 dBc/Hz, typical
≥10 MHz	≤ -137 dBc/Hz ^a	≤ -141 dBc/Hz, typical

	Specifications	Supplemental Information
Residual FM		
1 kHz RBW, 1 kHz VBW (<i>Option 1D5</i>)	$\leq 150 \text{ Hz} \times N \text{ p-p in } 100 \text{ ms}$	
10 Hz RBW, 10 Hz VBW (<i>Option 1DR and 1D5</i>)	$\leq 100 \text{ Hz} \times N \text{ p-p in } 100 \text{ ms}$	
10 Hz RBW, 10 Hz VBW (<i>Option 1DR</i>)	$\leq 2 \text{ Hz} \times N \text{ p-p in } 20 \text{ ms}$	
System-Related Sidebands, offset from CW signal		$\leq 10 \text{ Hz} \times N \text{ p-p in } 20 \text{ ms,}$ characteristic
$\geq 30 \text{ kHz}$	$\leq -65 \text{ dBc}^a$	
Line-Related Sidebands, offset from CW signal (<i>Option 1DR</i>)		
$< 300 \text{ Hz}$		$\leq -50 \text{ dBc}^a, \text{ characteristic}$
$> 300 \text{ Hz to } 30 \text{ kHz}$		$\leq -55 \text{ dBc}^a, \text{ characteristic}$

a. Add $20 \text{ Log}(N)$ for frequencies $> 6.7 \text{ GHz}$

Noise Sidebands Normalized to 1 Hz Versus Offset from Carrier

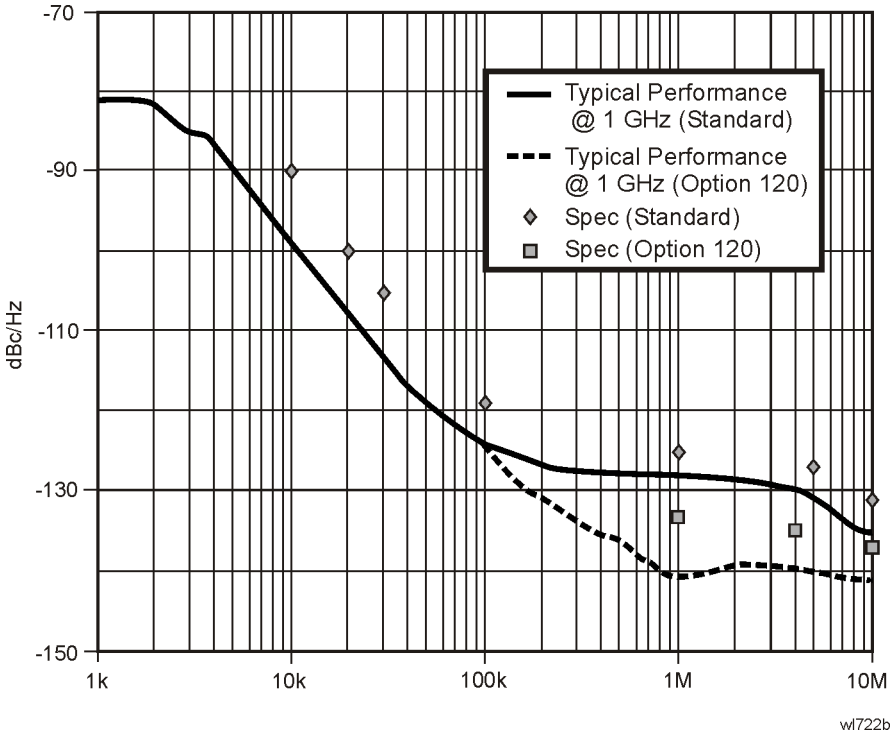

Amplitude

Amplitude specifications do not apply for the negative peak detector mode.

	Specifications	Supplemental Information
Measurement Range	Displayed Average Noise Level to Maximum Safe Input Level	
Input Attenuator Range	0 to 65 dB, in 5 dB steps	0 to 75 dB, in 5 dB steps, characteristic

	Specifications	Supplemental Information
Maximum Safe Input Level		
Average Continuous Power (Input attenuator setting ≥ 5 dB)	+30 dBm (1 W)	
Peak Pulse Power (for < 10 μ sec pulse width, $< 1\%$ duty cycle, and input attenuation ≥ 30 dB)	+50 dBm (100 W)	
dc		
dc Coupled	0 Vdc	
ac Coupled	50 Vdc	

	Specifications	Supplemental Information
1 dB Gain Compression		
Total power at input mixer ^{a,b}		
50 MHz to 3.0 GHz	0 dBm	
3.0 GHz to 6.7 GHz	0 dBm	
6.7 GHz to 13.2 GHz	-3 dBm	
Preamp On (<i>Option IDS</i>)		
Total power at the preamp ^c		-20 dBm, characteristic

a. Mixer power level (dBm) = input power (dBm) – input attenuation (dB).

b. For resolution bandwidths 1 kHz to 30 kHz, the maximum input signal amplitude must be \leq reference level +10 dB.

c. Total power at the preamp (dBm) = total power at the input (dBm) – input attenuation (dB).

	Specifications		Supplemental Information	
Displayed Average Noise Level (Input terminated, 0 dB attenuation, sample detector, Reference Level = -70 dBm)				
	1 kHz RBW 30 Hz VBW	10 Hz RBW 1 Hz VBW (<i>Option IDR</i>)	1 kHz RBW 30 Hz VBW (typical)	10 Hz RBW 1 Hz VBW (<i>Option IDR</i>) (typical)
30 Hz to 9 kHz (<i>Option UKB</i>)				≤ -93 dBm
9 kHz to 100 kHz				≤ -109 dBm
100 kHz to 1 MHz				≤ -135 dBm
1 MHz to 10 MHz			≤ -117 dBm	≤ -137 dBm
1 MHz to 10 MHz (<i>Option 120</i>)			≤ -120 dBm	≤ -139 dBm
10 MHz to 1.0 GHz	≤ -116 dBm	≤ -135 dBm	≤ -119 dBm	≤ -139 dBm
1.0 GHz to 2.0 GHz	≤ -116 dBm	≤ -135 dBm	≤ -120 dBm	≤ -140 dBm
2.0 GHz to 3.0 GHz	≤ -112 dBm	≤ -131 dBm	≤ -118 dBm	≤ -138 dBm
3.0 GHz to 6.0 GHz	≤ -112 dBm	≤ -131 dBm	≤ -118 dBm	≤ -138 dBm
6.0 GHz to 12 GHz	≤ -111 dBm	≤ -130 dBm	≤ -117 dBm	≤ -137 dBm
12 GHz to 13.2 GHz	≤ -107 dBm	≤ -126 dBm	≤ -114 dBm	≤ -134 dBm
Preamp On (<i>Option IDS</i>)	1 kHz RBW 30 Hz VBW	10 Hz RBW 1 Hz VBW (<i>Option IDR</i>)	1 kHz RBW 30 Hz VBW (typical)	10 kHz RBW 1 Hz VBW (<i>Option IDR</i>) (typical)
0 to 55 °C				
10 MHz to 1.0 GHz	≤ -131 dBm	≤ -150 dBm		
1.0 GHz to 2.0 GHz	≤ -131 dBm	≤ -150 dBm		
2.0 GHz to 3.0 GHz	≤ -127 dBm	≤ -146 dBm		
20 to 30 °C				
1 MHz to 10 MHz			≤ -135 dBm	≤ -155 dBm
10 MHz to 1.0 GHz	≤ -132 dBm	≤ -151 dBm	≤ -137 dBm	≤ -157 dBm
1.0 GHz to 2.0 GHz	≤ -132 dBm	≤ -151 dBm	≤ -135 dBm	≤ -155 dBm
2.0 GHz to 3.0 GHz	≤ -130 dBm	≤ -149 dBm	≤ -132 dBm	≤ -152 dBm

	Specifications	Supplemental Information
Display Range		
Log Scale	Ten divisions displayed; 0.1, 0.2, 0.5 dB/division and 1 to 20 dB/division in 1 dB steps	
RBW \geq 1 kHz	Calibrated 0 to -85 dB from Reference Level	
RBW \leq 300 Hz (<i>Option IDR</i>)	Calibrated 0 to -120 dB ^a from Reference Level	
Linear Scale	Ten divisions	
Scale Units	dBm, dBmV, dB μ V, dB μ A, A, V, and W	
(<i>Option BAA, 106</i>)	Add Hz	

- a. 0 to -70 dB range when span = 0 Hz, or when IF Gain fixed:
(:DISPlay:WINDow:TRACe:Y[:SCALE]:LOG:RANGE:AUTO OFF).

	Specifications	Supplemental Information
Marker Readout Resolution		
Log scale		
RBW \geq 1 kHz		
0 to -85 dB from ref level	0.04 dB	
RBW \leq 300 Hz (<i>Option IDR</i>)		
0 to -120 dB from ref level	0.04 dB	
Linear scale	0.01% of Reference Level	
Fast Sweep Times for Zero Span		
(<i>Option AYX</i>) ^a		
For sweep times		
$\frac{\text{sweep points} - 1}{20 \text{ MHz}}$ to		
$\frac{\text{sweep points} - 1}{100 \text{ kHz}}$		
Log		
0 to -85 dB from ref level	0.3 dB	
Linear	0.3% of Reference Level for linear scale	

	Specifications	Supplemental Information
<p><i>(Option B7D)</i> For sweep times $\frac{\text{sweep points} - 1}{40 \text{ MHz}}$ to $\frac{\text{sweep points} - 1}{100 \text{ kHz}}$</p> <p>Log 0 to -85 dB from ref level</p> <p>Linear</p>	<p>0.2 dB</p> <p>0.2% of Reference Level for linear scale</p>	

a. For firmware revisions prior to A.04.00, 20 μ s to <5 ms.

	Specifications	Supplemental Information
<p>Frequency Response</p> <p>50 Ω, Absolute^a/Relative</p> <p>10 dB attenuation (dc coupled)</p> <p>9 kHz to 3.0 GHz</p> <p>20 to 30 °C</p> <p>0 to 55 °C</p> <p>(ac coupled)</p> <p>100 kHz to 3.0 GHz</p> <p>20 to 30 °C</p> <p>0 to 55 °C</p> <p>800 MHz to 1.0 GHz^b</p> <p>20 to 30 °C</p> <p>0 to 55 °C</p> <p>1.7 GHz to 2.0 GHz</p> <p>20 to 30 °C</p> <p>0 to 55 °C</p>	<p>± 0.46 dB</p> <p>± 0.76 dB</p> <p>± 0.50 dB</p> <p>± 1.0 dB</p> <p>± 0.50 dB</p> <p>± 1.0 dB</p> <p>± 0.50 dB</p> <p>± 1.0 dB</p>	<p>± 0.14 dB, typical</p> <p>± 0.10 dB, typical</p> <p>± 0.08 dB, typical</p>

	Specifications	Supplemental Information
<i>(Option UKB)</i>		
100 Hz to 3.0 GHz (dc coupled)		
20 to 30 °C	±0.50 dB	
0 to 55 °C	±1.00 dB	
30 Hz to 3.0 GHz (dc coupled)		
20 to 30 °C		±0.5 dB, characteristic
0 to 55 °C		±1.0 dB, characteristic
Absolute ^a /Relative, Preamp On <i>(Option IDS)</i>		
0 dB attenuation		
1 MHz to 3.0 GHz		
20 to 30 °C	±1.5 dB	
0 to 55 °C	±2.0 dB	
800 MHz to 1.0 GHz		
20 to 30 °C	±1.5 dB	±0.35 dB, typical
0 to 55 °C	±2.0 dB	
1.7 GHz to 2.0 GHz		
20 to 30 °C	±1.5 dB	±0.26 dB, typical
0 to 55 °C	±2.0 dB	
Preselector centered for frequency >3.0 GHz		
10 dB attenuation		
3.0 GHz to 6.7 GHz (ac or dc coupled)		
Absolute ^a		
20 to 30 °C	±1.5 dB	
0 to 55 °C	±2.5 dB	
Relative		
20 to 30 °C	±1.3 dB	
0 to 55 °C	±1.5 dB	

	Specifications	Supplemental Information
6.7 GHz to 13.2 GHz (ac or dc coupled)		
Absolute ^a		
20 to 30 °C	±2.0 dB	
0 to 55 °C	±3.0 dB	
Relative		
20 to 30 °C	±1.8 dB	
0 to 55 °C	±2.0 dB	

- a. Absolute frequency response values are referenced to the amplitude at 50 MHz.
b. This specification applies only to analyzers with serial numbers ≥ US39440327.

	Specifications	Supplemental Information
Input Attenuation Switching Uncertainty at 50 MHz		
Attenuator Setting		
0 dB to 5 dB	±0.3 dB	
10 dB	Reference	
15 dB	±0.3 dB	
20 to 65 dB attenuation	±(0.1 dB + 0.01 × Attenuator Setting)	

Attenuation Accuracy Relative to the 10 dB Attenuator Setting, Characteristic		
	Frequency Range	
Attenuation	dc–3.0 GHz	3.0–13.2 GHz
0 dB	±0.3 dB	±0.5 dB
5 dB	±0.3 dB	±0.5
10 dB	Reference	Reference
15 dB	±0.4 dB	±0.5 dB
20 dB	±0.4 dB	±0.5 dB
25 dB	±0.5 dB	±0.6 dB
30 dB	±0.5 dB	±0.6 dB
35 dB	±0.6 dB	±0.7 dB

Attenuation Accuracy Relative to the 10 dB Attenuator Setting, Characteristic		
	Frequency Range	
Attenuation	dc–3.0 GHz	3.0–13.2 GHz
40 dB	±0.6 dB	±0.7 dB
45 dB	±0.7 dB	±1.0 dB
50 dB	±0.7 dB	±1.0 dB
55 dB	±0.9 dB	±1.1 dB
60 dB	±0.9 dB	±1.1 dB
65 dB	±1.0 dB	±1.6 dB

	Specifications	Supplemental Information
Preamp (<i>Option IDS</i>)		Refer also to Displayed Average Noise Level specification
Gain		+20 dB, nominal ^a
Noise figure		5 dB, characteristic

a. Amplifier is between the input attenuator and the input mixer.

	Specifications	Supplemental Information
Absolute Amplitude Accuracy		
At reference settings ^a	±0.34 dB	±0.13 dB, typical
Preamp On ^b (<i>Option IDS</i>)	±0.37 dB	±0.14 dB, typical
Overall Amplitude Accuracy^c		
20 to 30 °C	± (0.54 dB + Absolute Frequency Response)	

- a. Settings are: reference level –20 dBm; input attenuation 10 dB; dc coupled; center frequency 50 MHz; RBW 1 kHz; VBW 1 kHz; scale linear or log; span 2 kHz; sweep time coupled, sample detector, signal at reference level.
- b. Settings are: reference level –30 dBm; input attenuation 0 dB; dc coupled; center frequency 50 MHz; RBW 1 kHz; VBW 1 kHz; scale linear or log; span 2 kHz; sweep time coupled, signal at reference level.
- c. For reference level 0 to –50 dBm; input attenuation 10 dB; dc coupled; RBW 1 kHz; VBW 1 kHz; scale log, log range 0 to –50 dB from reference level; sweep time coupled; signal input 0 to –50 dBm; span ≤20 kHz.

	Specifications	Supplemental Information	
RF Input VSWR (at tuned frequency)		characteristic	characteristic

	Specifications	Supplemental Information	
Attenuator setting 0 dB	9 kHz to 100 kHz	(dc coupled) ≤3.0:1	(ac coupled)
	100 kHz to 13.2 GHz	≤3.0:1	≤3.0:1
	100 Hz to 100 kHz (Option UKB)	≤1.1:1	
Attenuator setting 5 dB	9 kHz to 100 kHz	(dc coupled) ≤2.0:1	(ac coupled)
	100 kHz to 300 kHz	≤1.4:1	≤2.3:1
	300 kHz to 1.0 MHz	≤1.4:1	≤1.6:1
	1.0 MHz to 3.0 GHz	≤1.4:1	≤1.4:1
	3.0 GHz to 6.7 GHz	≤1.4:1	≤1.7:1
	6.7 GHz to 13.2 GHz	≤1.7:1	≤1.9:1
	100 Hz to 100 kHz (Option UKB)	≤1.1:1	
Attenuator setting 10 to 65 dB	9 kHz to 100 kHz	(dc coupled) ≤2.0:1	(ac coupled)
	100 kHz to 300 kHz	≤1.3:1	≤2.1:1
	300 kHz to 1.0 MHz	≤1.3:1	≤1.5:1
	1.0 MHz to 3.0 GHz	≤1.3:1	≤1.3:1
	3.0 GHz to 6.7 GHz	≤1.3:1	≤1.5:1
	6.7 GHz to 13.2 GHz	≤1.5:1	≤1.7:1
	100 Hz to 100 kHz (Option UKB)	≤1.1:1	

	Specifications	Supplemental Information
Auto Alignment^a		
Sweep-to-sweep variation		±0.1 dB, characteristic

a. Set **Auto Align** to **Off** and use **Align Now, All** to eliminate this variation.

	Specifications	Supplemental Information
Resolution Bandwidth Switching Uncertainty (at Reference Level)		

	Specifications	Supplemental Information
1 kHz RBW	Reference	
3 kHz to 3 MHz RBW	± 0.3 dB	
5 MHz RBW	± 0.6 dB	
10 Hz to 300 Hz RBW (<i>Option 1DR</i>)	± 0.3 dB	

	Specifications	Supplemental Information
Reference Level		
Range	-149.9 dBm to maximum mixer level + attenuator setting	
Resolution		
Log Scale	± 0.1 dB	
Linear Scale	$\pm 0.12\%$ of Reference Level	
Accuracy (at a fixed frequency, a fixed attenuator, and referenced to -30 dBm (-10 dBm, Preamp On (<i>Option 1DS</i>)))		
Reference Level (dBm) – input attenuator setting (dB) + preamp gain (dB)		
-10 dBm to > -60 dBm	± 0.3 dB	
-60 dBm to > -85 dBm	± 0.5 dB	
-85 dBm to -90 dBm	± 0.7 dB	

	Specifications	Supplemental Information
Display Scale Switching Uncertainty		
Switching between Linear and Log	± 0.15 dB at reference level	
Log Scale Switching	No error	

	Specifications	Supplemental Information
Display Scale Fidelity		
Log Maximum Cumulative RBW ≥ 1 kHz		

	Specifications	Supplemental Information
dB Below Reference Level		
0 dB Reference	0 dB	
> 0 to 10 dB	± 0.22 dB	± 0.08 dB, typical
> 10 to 20 dB	± 0.24 dB	± 0.09 dB, typical
> 20 to 30 dB	± 0.26 dB	± 0.10 dB, typical
> 30 to 40 dB	± 0.40 dB	± 0.23 dB, typical
> 40 to 50 dB	± 0.57 dB	± 0.35 dB, typical
> 50 to 60 dB	± 0.57 dB	± 0.35 dB, typical
> 60 to 70 dB	± 0.66 dB	± 0.39 dB, typical
> 70 to 80 dB	± 0.66 dB	± 0.46 dB, typical
> 80 to 85 dB	± 1.15 dB	± 0.79 dB, typical
RBW \leq 300 Hz (<i>Option IDR</i>)		
Span > 0 Hz		
Auto range On		
0 to 98 dB below reference level	$\pm(0.3 \text{ dB} + 0.01 \times \text{dB from reference level})$	
> 98 to 120 dB below reference level		± 2.0 dB, characteristic
Auto range Off		
0 to 60 dB below reference level	$\pm(0.3 \text{ dB} + 0.015 \times \text{dB from reference level})$	
> 60 to 70 dB below reference level	± 1.5 dB	
Span = 0 Hz ^a		
0 to 60 dB below reference level	$\pm(0.3 \text{ dB} + 0.015 \times \text{dB from reference level})$	
> 60 to 70 dB below reference level	± 1.5 dB	

	Specifications	Supplemental Information
Log Incremental Accuracy		
0 to 80 dB ^b below reference level	±0.4 dB/4 dB	
Linear Accuracy	±2% of Reference Level	

- a. The SCPI command for auto range off is:
(:DISPlay:WINDow:TRACe:Y[:SCALe]:LOG:RANGe:AUTO OFF)
- b. 0 to -50 dB for RBWs ≤ 300 Hz and span = 0 Hz, or when auto ranging is off.

	Specifications	Supplemental Information
Spurious Responses		
Second Harmonic Distortion		
Input Signal		
10 MHz to 500 MHz	< -65 dBc for -30 dBm signal at input mixer ^a	+35 dBm SHI (second harmonic intercept)
500 MHz to 1.5 GHz	< -75 dBc for -30 dBm signal at input mixer ^a	+45 dBm SHI
1.5 GHz to 2.0 GHz	< -85 dBc for -10 dBm signal at input mixer ^a	+75 dBm SHI
2.0 GHz to 3.35 GHz	< -100 dBc ^b for -10 dBm signal at input mixer ^a	+90 dBm SHI
3.35 GHz to 6.6 GHz	< -100 dBc ^b for -10 dBm signal at input mixer ^a	+90 dBm SHI
Preamp On (<i>Option 1DS</i>) 10 MHz to 1.5 GHz		-5 dBm SHI, characteristic
Third Order Intermodulation Distortion		
10 MHz to 100 MHz		+7 dBm TOI (third order intercept), characteristic
100 MHz to 3 GHz	< -85 dBc for two -30 dBm signals at input mixer ^a and >50 kHz separation	+12.5 dBm TOI +16 dBm TOI, typical
3.0 GHz to 6.7 GHz	< -82 dBc for two -30 dBm signals at input mixer ^a and >50 kHz separation	+11 dBm TOI +18 dBm TOI, typical

	Specifications	Supplemental Information
6.7 GHz to 13.2 GHz	< -75 dBc for two -30 dBm signals at input mixer ^a and >50 kHz separation	+7.5 dBm TOI +12 dBm TOI, typical
Preamp On (<i>Option 1DS</i>) 10 MHz to 3 GHz		-16 dBm TOI, characteristic
Other Input Related Spurious		
Inband Responses		
>30 kHz offset	< -65 dBc for -20 dBm signal at input mixer ^a	
Out-of-band Responses	< -80 dBc for -10 dBm signal at input mixer ^a	

a. Mixer power level (dBm) = input power (dBm) – input attenuation (dB).

b. or signal below displayed average noise level.

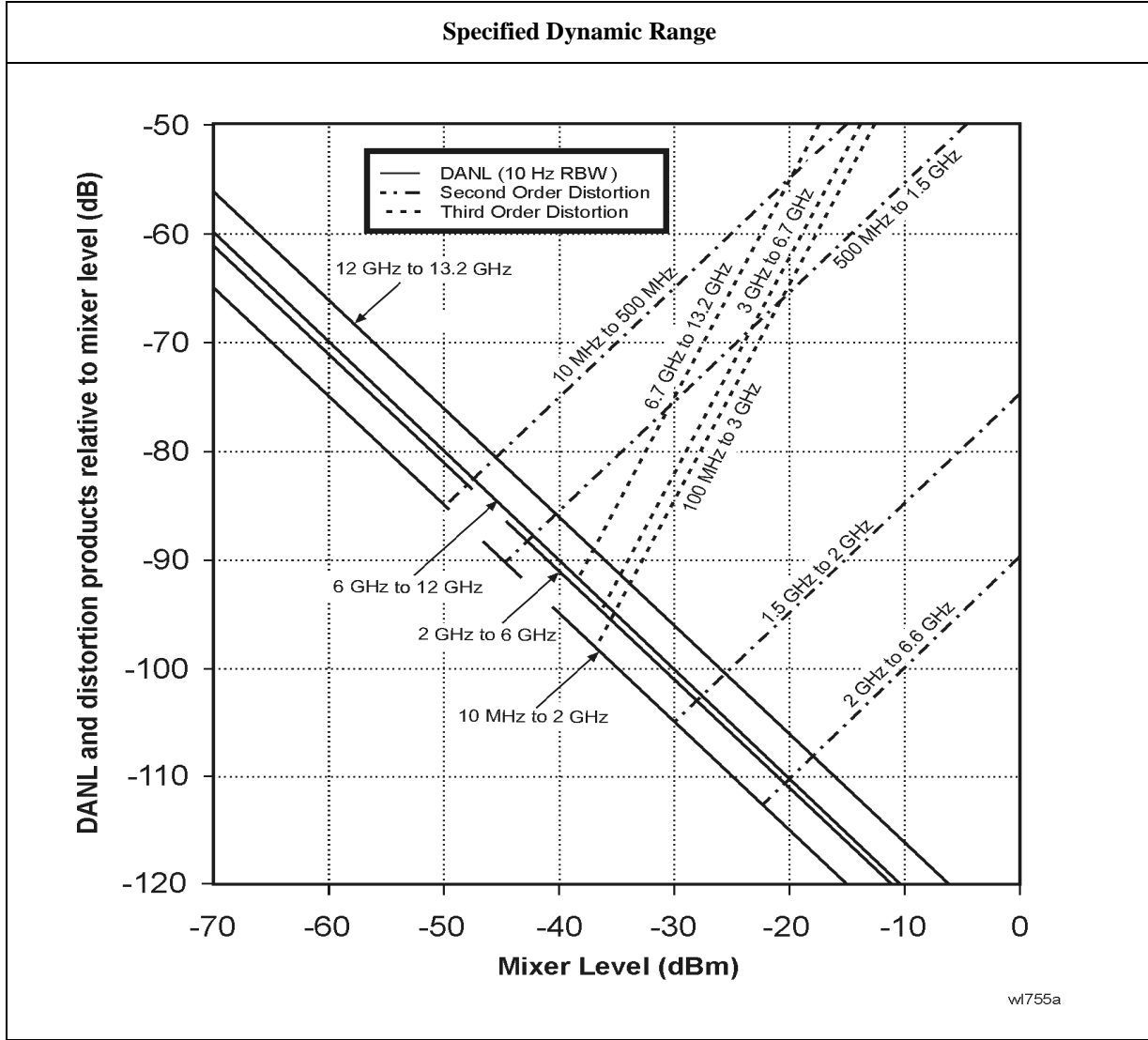

	Specifications	Supplemental Information
Residual Responses (Input terminated and 0 dB attenuation) 150 kHz to 6.7 GHz	< -90 dBm	

Options

Time Gated Spectrum Analysis (Option 1D6)

	Specifications	Supplemental Information
Gate Delay		
Range	1 μ s to 400 s	
Accuracy	$\pm(500 \text{ ns} + (0.01\% \times (\text{maximum of gate delay or length})))$	From gate trigger input to positive edge of gate output
Gate Length		
Range	1 μ s to 400 s	
Accuracy	$\pm(500 \text{ ns} + (0.01\% \times (\text{maximum of gate delay or length})))$	From positive edge to negative edge of gate output
Resolution	$((\text{maximum of gate delay or length in seconds})/65000)$ rounded up to nearest μ s	Dependent on the greater of gate delay or gate length
Additional Amplitude Error^a		
Log Scale	± 0.2 dB	
Linear Scale	$\pm 0.1\%$ of reference level	

a. While in gate mode.

Tracking Generator (Option 1DN)

The spectrum analyzer/tracking generator combination will meet its specification after a cable (8120-5148) and adapter are connected between RF OUT and INPUT and **Align Now, TG** has been run.

	Specifications	Supplemental Information
Warm-up	5 minutes	

	Specifications	Supplemental Information
Output Frequency Range	9 kHz to 3.0 GHz	

	Specifications	Supplemental Information
Minimum Resolution BW	1 kHz	Not usable with resolution bandwidths ≤ 300 Hz (<i>Option 1DR</i>)

	Specifications	Supplemental Information
Output Power Level		
Range	-2 to -66 dBm	
Resolution	0.1 dB	
Absolute Accuracy (at 50 MHz with coupled source attenuator, referenced to -20 dBm)	± 0.75 dB	
Vernier		
Range	8 dB	
Accuracy (with coupled source attenuator, 50 MHz, -20 dBm)		
Incremental	± 0.2 dB/dB	
Cumulative	± 0.5 dB, total	
Output Attenuator Range	0 to 56 dB in 8 dB steps	

	Specifications	Supplemental Information
Maximum Safe Reverse Level		+30 dBm (1 W), 50 Vdc, characteristic

	Specifications	Supplemental Information
Output Power Sweep		
Range	(-10 to -2 dBm) – (Source Attenuator Setting)	
Resolution	0.1 dB	
Accuracy (zero span)	<1 dB peak-to-peak	

	Specifications	Supplemental Information
Output Flatness		
Referenced to 50 MHz, -20 dBm		
9 kHz to 10 MHz	±3 dB	
10 MHz to 3 GHz	±2 dB	

	Specifications	Supplemental Information
Spurious Outputs		
(-2 dBm output)		
Harmonic Spurs		
TG Output 9 kHz to 20 kHz	≤ -15 dBc	
TG Output 20 kHz to 3 GHz	≤ -25 dBc	
Non-harmonic Spurs		
TG Output 9 kHz to 2 GHz	≤ -27 dBc	
TG Output 2 GHz to 3 GHz	≤ -23 dBc	
LO Feedthrough		
LO Frequency 3.921409 GHz to 6.9214 GHz	≤ -16 dBm	

	Specifications	Supplemental Information
Dynamic Range	Maximum Output Power Level – Displayed Average Noise Level	

	Specifications	Supplemental Information
Output Tracking Drift Swept Tracking Error		1.5 kHz/5 minute, characteristic Usable in 1 kHz RBW after 5 minutes of warm-up

	Specifications	Supplemental Information
RF Power-Off Residuals 9 kHz to 3 GHz		< -120 dBm, characteristic

	Specifications	Supplemental Information
Output Attenuator Repeatability 9 kHz to 300 MHz 300 MHz to 2 GHz 2 GHz to 3 GHz		±0.1 dB, characteristic ±0.2 dB, characteristic ±0.3 dB, characteristic

	Specifications	Supplemental Information
Output VSWR 0 dB attenuation ≥ 8 dB attenuation		<2.0:1, characteristic <1.5:1, characteristic

	Specifications	Supplemental Information
Output Attenuator Accuracy 0 dB 8 dB 16 dB 24 dB 32 dB 40 dB 48 dB 56 dB	Reference	±0.5 dB, characteristic ±0.5 dB, characteristic ±0.5 dB, characteristic ±0.6 dB, characteristic ±0.8 dB, characteristic ±1.0 dB, characteristic ±1.1 dB, characteristic

Tracking Generator Output Accuracy
Relative Accuracy (Referred to -20 dBm) = Output Attenuator Accuracy + Vernier Accuracy + Output Flatness
Absolute Accuracy = Relative Accuracy (Referred to -20 dBm) + Absolute Accuracy at 50 MHz

Bluetooth FM Demodulation (Option 106)

The FM demodulation characteristics will apply after an Align Now, FM Demod has been run.

	Specifications	Supplemental Information
Optimum Input Level		$\geq (-40 \text{ dBm} + \text{attenuator setting} - \text{preamp gain})$ and within 10 dB of the reference level
FM Deviation		
Range		$\pm 200 \text{ kHz}$, nominal
Resolution		Provides 400 Hz display annotation resolution, nominal
Accuracy ^a		
Input level = -30 dBm		$\pm 10 \text{ kHz}$, typical
Reference level = -30 dBm		$\pm 4 \text{ kHz}$ with video averaging On and averages ≥ 25
FM Rate = 500 kHz sine		
VBW = 3 MHz,		
RBW = 5 MHz,		
FM Deviation = 140 kHz		
Offset Error ^a		$\pm 1 \text{ kHz}$, typical
FM Bandwidth (-3 dB)		1.2 MHz, nominal

a. In time domain sweeps (span = 0 Hz).

Bluetooth Measurements Personality (Option 228)

The demodulation related nominals will apply after an Align Now, FM Demod has been run.

	Specifications	Supplemental Information
In-Band Frequency Range		
Bluetooth (ISM) Band	2400 to 2483.5 MHz	

	Specifications	Supplemental Information
Output Power (Option AYX or B7D)		
Range at RF Input	30 to -40 dBm	
(Option IDS)	30 to -60 dBm	
Absolute Amplitude Accuracy		See, "Absolute Amplitude Accuracy," on page 190.
Average type	Video, Power	
Average mode	Exponential, Repeat	
Trigger source	Video, RF burst ^a , External, Free Run	
Burst synch	RF Amplitude, Preamble ^b , None	

a. Requires Option B7E

b. Requires Option 106 Bluetooth FM demodulation.

	Specifications	Supplemental Information
Modulation Characteristics^a (Option 106 and AYX or B7D)		
Range at RF Input	30 to -40 dBm	
(Option IDS)	30 to -60 dBm	
FM Deviation		
Range		±200 kHz, nominal
Accuracy		±4 kHz, nominal (25 measurement averages, signal level > -30 dBm)
Payload data	11110000, 10101010, auto-detect	
Average mode	Exponential, Repeat	

	Specifications	Supplemental Information
Trigger source	Video, RF burst ^b , External, Free Run	
Burst synch	RF Amplitude, Preamble ^c , None	
Limits	$\Delta f_2/\Delta f_1$ lower, Δf_1 max lower/upper Δf_2	

- a. The DUT must have frequency hopping disabled.
- b. Requires Option B7E
- c. Requires Option 106 Bluetooth FM demodulation.

	Specifications	Supplemental Information
Carrier Frequency Drift ^a (Option 106 and AYZ or B7D)		
Range at RF Input	30 to -40 dBm	
(Option 1DS)	30 to -60 dBm	
Measurement range		±100 kHz, nominal
Measurement accuracy		±4 kHz, nominal (25 measurement averages, signal level > -30 dBm)
Average mode	Exponential, Repeat	
Trigger source	Video, RF burst ^b , External, Free Run	
Burst synch	Preamble ^c , None	

- a. The DUT must have frequency hopping disabled.
- b. Requires Option B7E
- c. Requires Option 106 Bluetooth FM demodulation.

	Specifications	Supplemental Information
Initial Carrier Frequency Tolerance (ICTF) ^a (Option 106 and AYZ or B7D)		
Range at RF Input	30 to -40 dBm	
(Option 1DS)	30 to -60 dBm	
Measurement range		±100 kHz, nominal
Measurement accuracy		±4 kHz, nominal (25 measurement averages, signal level > -30 dBm)

	Specifications	Supplemental Information
Average mode	Exponential, Repeat	
Trigger source	Video, RF burst ^b , External, Free Run	
Burst synch	RF Amplitude, Preamble ^c , None	
Limits	ICFT upper/lower	

- a. The DUT must have frequency hopping disabled.
- b. Requires Option B7E
- c. Requires Option 106 Bluetooth FM demodulation.

FM Demodulation (Option BAA)

The FM demodulation characteristics will apply after an **Align Now, FM Demod** has been run.

	Specifications	Supplemental Information
Optimum Input Level		$\geq (-60 \text{ dBm} + \text{attenuator setting} - \text{preamp gain})$ and within 30 dB of the reference level
FM Deviation		
Range		10 kHz to 1 MHz
Resolution		Provides 1 Hz display annotation resolution
FM Deviation Range		
10 kHz to 40 kHz		12 Hz, characteristic
>40 kHz to 200 kHz		60 Hz, characteristic
>200 kHz to 1 MHz		300 Hz, characteristic
Accuracy ^a		
FM Rate < FM BW/100, VBW $\geq (30 \times \text{FM Rate})$, RBW > the maximum of (30 \times FM deviation) or (30 \times FM Rate)		< (2% of FM deviation range + 2 \times Resolution), characteristic
Offset Error ^a		5% of FM Deviation Range + 300 Hz, characteristic
FM Bandwidth (-3 dB)		
FM Deviation Range		
10 kHz to 40 kHz		7.5 \times FM deviation range, characteristic
>40 kHz to 200 kHz		1.3 \times FM deviation range, characteristic
>200 kHz to 1 MHz		0.3 \times FM deviation range, characteristic

a. In time domain sweeps (span = 0 Hz).

TV Trigger and Picture On Screen (Option B7B)

Option BAA is required.

	Specifications	Supplemental Information
TV Trigger and Picture On Screen		TV Trigger initiates a sweep of the analyzer after the sync pulse of a selected line of a TV video field. Picture On Screen displays the TV picture on the analyzer display.
Amplitude Requirements TV Source: SA		Top 50% of linear display, characteristic
TV Source: EXT VIDEO IN		500 mVp-p to 2 Vp-p, characteristic
Compatible Standards	NTSC-M, NTSC-Japan, PAL-M, PAL-B,D,G,H,I, PAL-N, PAL-N Combination, SECAM-L	
Field Selection	Entire frame, even, odd	
Sync Polarity	Positive or negative	
TV Trigger		
Line Selection	1 to 525, or 1 to 625, standard dependent	

cdmaOne Measurement Personality (Option BAC)

Unless otherwise noted, all specifications are with RF input range auto, default cdmaOne measurement settings, and in the in-band frequency range. *Option B72* is required.

	Specifications	Supplemental Information
In-Band Frequency Range		
Cellular bands	824 to 870 MHz 869 to 925 MHz	
PCS bands	1715 to 1780 MHz 1805 to 1870 MHz 1850 to 1910 MHz 1930 to 1990 MHz	

	Specifications	Supplemental Information
Adjacent Channel Power Ratio^a		
Carrier power range at RF Input	30 to -20 dBm	
Dynamic range ^b		Referenced to average power of carrier in 1.23 MHz BW
Offset Frequency	Integration BW	
750 kHz	30 kHz	-70.0 dBc, characteristic
885 kHz	30 kHz	-73.5 dBc, characteristic
1.25625 MHz	12.5 kHz	-78.0 dBc, characteristic
1.98 MHz	30 kHz	-75.5 dBc, characteristic
2.75 MHz	1 MHz	-60.5 dBc, characteristic
Relative accuracy ^c	See Display Scale Fidelity	
Resolution	0.01 dB	

- This measurement is available with personality revisions of A.02.00 or later.
- IS-97A nominal base station test model levels (fraction of carrier power); Pilot: 0.20 (-7.0 dBc), Sync: 0.0471 (-13.3 dBc), Paging: 0.1882 (-7.3 dBc), 6 Traffic channels: 0.09412 (-10.3 dBc)
- Does not include uncertainty due to noise.

	Specifications	Supplemental Information
Channel Power (1.23 MHz Integration BW)		Integration BW range 1 kHz to 10 MHz
Range at RF Input	30 to -70 dBm	
Absolute power accuracy for in-band signal (Mean channel power at RF Input, plus any external attenuation, excluding mismatch error)		
Cellular Bands		
30 to -5 dBm 20 to 30 °C	±0.80 dB	±0.36 dB, typical
0 to 55 °C	±1.13 dB	
-5 to -25 dBm 20 to 30 °C	±0.77 dB	±0.33 dB, typical
0 to 55 °C	±1.10 dB	
-25 to -45 dBm 20 to 30 °C	±0.65 dB	±0.29 dB, typical
0 to 55 °C	±1.00 dB	
-45 to -55 dBm 20 to 30 °C	±0.72 dB	±0.36 dB, typical
0 to 55 °C	±1.01 dB	
-55 to -70 dBm 20 to 30 °C	±0.86 dB	±0.47 dB, typical
0 to 55 °C	±1.28 dB	
PCS Bands		
30 to -5 dBm 20 to 30 °C	±0.70 dB	±0.29 dB, typical
0 to 55 °C	±1.15 dB	
-5 to -25 dBm 20 to 30 °C	±0.67 dB	±0.26 dB, typical
0 to 55 °C	±1.11 dB	
-25 to -45 dBm 20 to 30 °C	±0.66 dB	±0.27 dB, typical
0 to 55 °C	±0.97 dB	

	Specifications	Supplemental Information
-45 to -55 dBm 20 to 30 °C	±0.73 dB	±0.34 dB, typical
0 to 55 °C	±0.98 dB	
-55 to -70 dBm 20 to 30 °C	±0.87 dB	±0.45 dB, typical
0 to 55 °C	±1.25 dB	

	Specifications	Supplemental Information
Channel power relative power accuracy (same channel, different Tx power, input attenuator fixed, RF input range manual).	See Display Scale Fidelity	

	Specifications	Supplemental Information
Receive Channel Power		
Absolute Power Accuracy		
Cellular bands		
30 to 0 dBm	±0.98 dB	±0.55 dB, typical
0 to -85 dBm	±2.02 dB	±1.33 dB, typical
PCS bands		
30 to 0 dB	±1.00 dB	±0.60 dB, typical
0 to -85 dBm	±1.52 dB	±0.84 dB, typical
Preamp (<i>Option IDS</i>)		
Cellular and PCS bands		
30 to -80 dBm	±2.45 dB	±1.70 dB, typical
-80 to -100 dBm	±3.20 dB	±2.30 dB, typical

	Specifications	Supplemental Information
Occupied Bandwidth		
Carrier power range	30 to -45 dBm	
Frequency resolution of occupied BW	1.88 kHz	
Frequency accuracy of occupied BW (1.23 MHz channel BW)		±15 kHz, characteristic
Frequency resolution of delta frequency	3.75 kHz	

	Specifications	Supplemental Information
Frequency accuracy of delta frequency		$\pm (35 \text{ kHz} + \text{frequency reference error} \times \text{carrier frequency})$, characteristic

	Specifications	Supplemental Information
Code Domain Power (Requires <i>Options 1D5, B7D, and B7E</i> . Measurement interval ≥ 1.25 ms unless otherwise noted.)		
Carrier power range at RF Input (Pilot channel power > -11 dBc)	30 to -13 dBm	30 to -65 dBm ^a , characteristic
Preamp (<i>Option 1DS</i>)	30 to -30 dBm	30 to -82 dBm ^a , characteristic
Measurement interval range	0.5 ms to 26.67 ms	
Code domain power		
Display dynamic range	50 dB	
Accuracy (Walsh channel power within 20 dB of total power)		± 0.2 dB, typical
Displayed resolution	0.01 dB	
Other reported power parameters (dB referenced to total power)		Average active traffic, maximum inactive traffic, average inactive traffic, pilot, paging, sync channels
Carrier frequency error (Measurement interval ≥ 2.5 ms)		Excludes frequency reference error.
Input frequency error range	± 100 kHz	± 200 kHz, typical
Accuracy	± 10 Hz	± 7 Hz, typical
Displayed resolution	Four digits	
Estimated Rho		
Range	0.9 to 1.0	0.5 to 1.0 ^b
Accuracy (With 9 channels active over the specified range) ^c		± 0.02 , characteristic
Displayed resolution	0.0001	

	Specifications	Supplemental Information
Pilot time offset		From even second signal to start of PN sequence
Range	–13.33 ms to +13.33 ms	
Accuracy	±150 ns	
Displayed resolution	Four digits	
Code domain timing		Pilot to code channel time tolerance
Range	±200 ns	
Accuracy (IS-97A nominal power levels) ^d		±7 ns, typical
Code domain phase		Pilot to code channel phase tolerance
Range	±200 mrad	
Accuracy (IS-97A nominal power levels) ^d		±10 mrad, typical
Displays		Power Graph and Metrics, or Power, Timing, and Phase Graphs

- a. Performance may degrade outside of the specified carrier power range at RF input listed in the specifications column.
- b. Performance may degrade outside of the estimated rho range listed in the specifications column.
- c. The Active Set Threshold is less than all active channels, but greater than –20 dBc.
- d. IS-97A nominal base station test model levels (fraction of carrier power); Pilot: 0.20 (–7.0 dBc), Sync: 0.0471 (–13.3 dBc), Paging: 0.1882 (–7.3 dBc), 6 Traffic channels: 0.09412 (–10.3 dBc)

	Specifications	Supplemental Information
Modulation Accuracy (Rho) (Requires <i>Options 1D5, B7D,</i> and <i>B7E</i> . Measurement interval ≥1.25 ms unless otherwise noted.)		
Carrier power range at RF Input	30 to –28 dBm	30 to –70 dBm ^a , characteristic
Preamp (<i>Option 1DS</i>)	30 to –45 dBm	30 to –87 dBm ^a , characteristic
Measurement interval range	0.15 ms to 26.67 ms	
Rho (waveform quality)		
Range	0.9 to 1.0	0.5 to 1.0 ^b , characteristic
Accuracy		±0.0016, typical
Displayed resolution	0.0001	

	Specifications	Supplemental Information
Carrier frequency error (Measurement interval ≥ 2.5 ms)		Excludes frequency reference error
Input frequency error range	± 100 kHz	± 200 kHz, typical
Accuracy	± 10 Hz	± 7 Hz, typical
Displayed resolution	Four digits	
Pilot time offset		From even second signal to start of PN sequence
Range	-13.33 ms to +13.33 ms	
Accuracy	± 150 ns	
Displayed resolution	Four digits	
EVM		
Floor		3.8%, typical
Accuracy ^c		$\pm 1.1\%$, typical
Displayed Resolution	0.01%	
Carrier feedthrough		
Floor		-51 dBc, typical
Accuracy (Carrier feedthrough ≥ -43 dBc)		± 2.3 dB, typical
Displayed resolution	0.01 dB	
Magnitude error		
Floor		3.8%, typical
Accuracy ^c		$\pm 1.1\%$, typical
Displayed resolution	0.01%	
Phase error		
Accuracy ^c		± 0.65 degrees, typical
Displayed resolution	0.01 degrees	
Displays		Numeric results or Numeric results and IQ graph

- a. Performance may degrade outside of the specified carrier power range at RF input listed in the specifications column.
- b. Performance may degrade outside of the rho range listed in the specifications column.
- c. Accuracy does not include the effects of the EVM floor. The measurement variance increases as the result approaches the EVM floor.

	Specifications	Supplemental Information
Spur Close (In Band)		
Carrier power range at RF Input	30 to -12 dBm	
Dynamic range		
Input power		
30 to 25 dBm	55 dB	
25 to 20 dBm	50 dB	
20 to -12 dBm	46 dB	
Relative accuracy	$\pm(2.7 \text{ dB} + 0.01 \times (\text{dB from reference level}))$	$\pm(0.3 \text{ dB} + 0.01 \times (\text{dB from reference level}))$, typical
Displayed resolution	0.01 dB	

	Specifications	Supplemental Information
Out-of-Band Spurious^a		Refer to the Amplitude specifications section in this guide.

a. The out-of-band measurement is made with the user-defined tables with 20 frequency ranges each (up to the top 10 spurs per range, 100 spurs maximum). Table parameters include frequency range, RBW, video BW, detector type, and amplitude test limits.

	Specifications	Supplemental Information
Receiver Spurious Emissions		
Spurious emission power range	-20 to -83 dBm	
Preamp On (<i>Option IDS</i>)	-40 to -101 dBm	
Absolute spurious emission power accuracy		
-20 to -60 dBm	$\pm 2.6 \text{ dB}$	$\pm 1.7 \text{ dB}$, typical
-60 to -83 dBm	$\pm 4.3 \text{ dB}$	$\pm 3.4 \text{ dB}$, typical
Preamp On (<i>Option IDS</i>)		
-40 to -70 dBm	$\pm 3.6 \text{ dB}$	$\pm 2.6 \text{ dB}$, typical
-70 to -101 dBm	$\pm 5.0 \text{ dB}$	$\pm 3.9 \text{ dB}$, typical

	Specifications	Supplemental Information
External Correction External attenuation, external gain Range Resolution	-90 to 90 dB 0.01 dB	

	Specifications	Supplemental Information
Trigger Trigger source (Actual available choices dependent on measurement) (Option B7D and B7E) Delay trigger Range Resolution RF burst trigger level (Option B7E) Trigger slope (External and RF burst) Frame timing period Frame synchronizing source Frame synchronizing slope	Free run, external Add RF Burst, frame 0 to 500 ms 300 ns 0 to -25 dBc Positive/Negative 50 ns to 13.6533 s External frame sync Positive/Negative	Rear panel connector labelled EXT FRAME SYNC (Option B7D)

	Specifications	Supplemental Information
Demod Trigger Source Even second input (Frame trigger only, Option B7D and B7E) PN offset range	0 to 511 x 64 [chips]	Rear panel connector labelled EXT FRAME SYNC

GSM Measurement Personality (Option BAH)

Unless otherwise noted, all specifications are with RF input range auto, default GSM measurement settings, and in the in-band frequency range. *Option 1D6* and *Option B72* are required.

	Specifications	Supplemental Information
In-Band Frequency Range		
GSM 900, P-GSM bands	890 to 915 MHz 935 to 960 MHz	
GSM 900, E-GSM bands	880 to 915 MHz 925 to 960 MHz	
GSM 900, R-GSM bands	876 to 915 MHz 921 to 960 MHz	
DCS 1800 bands	1710 to 1785 MHz 1805 to 1880 MHz	
PCS 1900 bands	1850 to 1910 MHz 1930 to 1990 MHz	

	Specifications	Supplemental Information
Transmitter Power (Requires <i>Option B7D</i> or <i>AYX</i>)		
Range at RF Input	30 to -60 dBm	
Absolute power accuracy for in-band signal (Mean channel power at RF Input, plus any external attenuation, excluding mismatch error)		
P-GSM, E-GSM, and R-GSM Bands		
30 to -20 dBm 20 to 30 °C	±0.89 dB	±0.39 dB, typical
0 to 55 °C	±1.65 dB	
-20 to -30 dBm 20 to 30 °C	±0.82 dB	±0.38 dB, typical
0 to 55 °C	±1.48 dB	

	Specifications	Supplemental Information
-30 to -40 dBm 20 to 30 °C	±0.87 dB	±0.39 dB, typical
0 to 55 °C	±1.47 dB	
-40 to -50 dBm 20 to 30 °C	±1.06 dB	±0.57 dB, typical
0 to 55 °C	±1.60 dB	
-50 to -60 dBm 20 to 30 °C	±1.19 dB	±0.70 dB, typical
0 to 55 °C	±1.71 dB	
DCS 1800 and PCS 1900 Bands		
30 to -20 dBm 20 to 30 °C	±0.76 dB ^a	±0.28 dB ^a , typical
0 to 55 °C	±1.26 dB ^a	
-20 to -30 dBm 20 to 30 °C	±0.66 dB ^a	±0.27 dB ^a , typical
0 to 55 °C	±1.06 dB ^a	
-30 to -40 dBm 20 to 30 °C	±0.71 dB ^a	±0.26 dB ^a , typical
0 to 55 °C	±1.00 dB ^a	
-40 to -50 dBm 20 to 30 °C	±0.90 dB ^a	±0.44 dB ^a , typical
0 to 55 °C	±1.13 dB ^a	
-50 to -60 dBm 20 to 30 °C	±1.03 dB ^a	±0.57 dB ^a , typical
0 to 55 °C	±1.24 dB ^a	

a. For Option UKB, add 0.10 dB.

	Specifications	Supplemental Information
Transmitter Power (Requires <i>Option B7D</i> or <i>AYX</i>)		
Range at RF Input	30 to -60 dBm	

	Specifications	Supplemental Information
<p>Absolute power accuracy for in-band signal (Mean channel power at RF Input, plus any external attenuation, excluding mismatch error)</p> <p>P-GSM, E-GSM, and R-GSM Bands</p>		
<p>30 to -20 dBm 20 to 30 °C</p>	±0.81 dB	±0.38 dB, typical
<p>0 to 55 °C</p>	±1.31 dB	
<p>-20 to -30 dBm 20 to 30 °C</p>	±0.74 dB	±0.37 dB, typical
<p>0 to 55 °C</p>	±1.14 dB	
<p>-30 to -40 dBm 20 to 30 °C</p>	±0.79 dB	±0.37 dB, typical
<p>0 to 55 °C</p>	±1.11 dB	
<p>-40 to -50 dBm 20 to 30 °C</p>	±0.95 dB	±0.53 dB, typical
<p>0 to 55 °C</p>	±1.21 dB	
<p>-50 to -60 dBm 20 to 30 °C</p>	±1.09 dB	±0.66 dB, typical
<p>0 to 55 °C</p>	±1.33 dB	
<p>DCS 1800 and PCS 1900 Bands</p>		
<p>30 to -20 dBm 20 to 30 °C</p>	±0.68 dB	±0.28 dB, typical
<p>0 to 55 °C</p>	±1.30 dB	
<p>-20 to -30 dBm 20 to 30 °C</p>	±0.61 dB	±0.27 dB, typical
<p>0 to 55 °C</p>	±1.12 dB	
<p>-30 to -40 dBm 20 to 30 °C</p>	±0.66 dB	±0.27 dB, typical
<p>0 to 55 °C</p>	±0.99 dB	
<p>-40 to -50 dBm 20 to 30 °C</p>	±0.82 dB	±0.43 dB, typical
<p>0 to 55 °C</p>	±1.09 dB	

	Specifications	Supplemental Information
-50 to -60 dBm 20 to 30 °C	±0.96 dB	±0.56 dB, typical
0 to 55 °C	±1.21 dB	

	Specifications	Supplemental Information
Transmitter Power Relative Power Accuracy (same channel, different Tx power, input attenuator fixed, RF input range manual).	See Display Scale Fidelity	

	Specifications	Supplemental Information
Power versus Time (Requires <i>Option B7D</i> or <i>AYX</i>)		
Carrier power range at RF Input	30 to -23 dBm	30 to -55 dBm ^a , characteristic
Preamplifier On (<i>Option 1DS</i>)	30 to -40 dBm	30 to -72 dBm ^a , characteristic
Time resolution accuracy		±1% of sweep time, characteristic
Maximum record length	8 time slots	
Burst to mask uncertainty (Requires <i>Option B7D</i> and <i>B7E</i>)	±1.0 bit	

a. Performance may degrade outside of the specified carrier power range at RF input listed in the specifications column.

	Specifications	Supplemental Information
Output RF Spectrum		
Carrier power range at RF Input		
Offsets ≤1800 kHz, 30 kHz RBW		30 to -5 dBm, characteristic
Offsets >1800 kHz, 100 kHz RBW		30 to -4 dBm, characteristic
Reference power accuracy	Same as Transmitter Power measurement	
Relative accuracy ^a	See Display Scale Fidelity	

	Specifications	Supplemental Information
Spectrum due to modulation displayed dynamic range ^{b,c}		
100 kHz offset		30 dB, characteristic
200 kHz offset		60 dB, characteristic
250 kHz offset		60 dB, characteristic
400 kHz offset		70 dB, characteristic
600 kHz to 1.8 MHz offset		79 dB, characteristic
1.8 to 6.0 MHz offset		75 dB, characteristic
> 6 MHz offset		76 dB, characteristic
Swept Mode Dynamic Range		70 dB, characteristic
Spectrum due to switching transients displayed dynamic range ^{b,c}		
400 kHz offset		62 dB, characteristic
600 kHz offset		79 dB, characteristic
1200 kHz offset		79 dB, characteristic
1800 kHz offset		80 dB, characteristic
Swept Mode Dynamic Range		70 dB, characteristic

- a. Does not include uncertainty due to noise.
- b. Displayed dynamic range for specific frequency offsets—applies to CW signal at the specified offset. Dynamic range with a GSM signal may differ.
- c. Using default settings, the RBW filter has a corrected noise BW and impulse BW equivalent to five-pole synchronously tuned filter.

	Specifications	Supplemental Information
Phase and Frequency Error (Requires <i>Option 1D5, B7D, and B7E</i>)		
Carrier power range at RF Input	30 to –23 dBm	30 to –55 dBm ^a , characteristic
Preamplifier On (<i>Option 1DS</i>)	30 to –40 dBm	30 to –72 dBm ^a , characteristic
Phase error		
Range	0 to 180°	
Displayed resolution	0.01°	
Accuracy (Averages ≥10)		
Peak	±2.1°	±1.5°, typical

	Specifications	Supplemental Information
RMS Frequency error	$\pm 1.1^\circ$	$\pm 0.6^\circ$, typical Excludes frequency reference error
Initial frequency error range	± 100 kHz	
Accuracy (Averages ≥ 10)	± 10 Hz	± 5 Hz, typical
I/Q offset range	-10 to -46 dBc	
Burst sync time uncertainty	± 0.1 bit	
Displays		Numeric summary

- a. Performance may degrade outside of the specified carrier power range at RF input listed in the specifications column.

	Specifications	Supplemental Information
Transmit Band Spurious		
Carrier power range at RF Input		30 to -12 dBm, typical
Dynamic range		
Upper and lower adjacent segments		55 dB, characteristic
Upper and lower segments		44 dB, characteristic
Relative accuracy		$\pm(0.3 \text{ dB} + 0.01 \times (\text{dB from reference level}))$, characteristic
Displayed resolution	0.01 dB	

	Specifications	Supplemental Information
Out-of-Band Spurious^a		
Absolute Spurious Power Accuracy		Refer to the Amplitude specifications section in this guide.
Sensitivity ^b		
RBW		
1 kHz		-95 dBm, characteristic
3 kHz		-90 dBm, characteristic
10 kHz		-85 dBm, characteristic
30 kHz		-78 dBm, characteristic
100 kHz		-71 dBm, characteristic
300 kHz		-64 dBm, characteristic

	Specifications	Supplemental Information
1 MHz		-57 dBm, characteristic
3 MHz		-50 dBm, characteristic

- a. The out-of-band spurious measurement is made in accordance with the tables defined in the appropriate GSM specification document. The measurement is made over several frequency ranges (up to 10 spurs per range, 100 spurs maximum).
- b. With input attenuation of 5 dB. For all other attenuation settings, add (input attenuation - 5) dB.

	Specifications	Supplemental Information
Receive Band Spurious		
Spurious emission power range ^a		-20 to -73 dBm, characteristic
Preamp On (<i>Option IDS</i>)		-40 to -91 dBm, characteristic
Absolute spurious emission power accuracy		
-20 to -60 dBm		±1.9 dB, characteristic
-60 to -73 dBm		±2.5 dB, characteristic
Preamp on (<i>Option IDS</i>)		
-40 to -70 dBm		±2.8 dB, characteristic
-70 to -91 dBm		±4.1 dB, characteristic

- a. Requires bandpass filter centered on receive band, peak detector mode, 0 dB attenuation, 100 kHz RBW. Does not include insertion loss of bandpass filter.

	Specifications	Supplemental Information
Amplitude Range Control		RF Input Autorange, Manually set Max Total Pwr Manually set Input Atten

	Specifications	Supplemental Information
External Gain/Attenuation Correction		
Base gain, base attenuation, mobile gain, mobile attenuation		
Range	0 to 81.9 dB	
Resolution	0.01 dB	

	Specifications	Supplemental Information
Trigger		
Trigger source (Actual available choices dependent on measurement) (<i>Option B7D and B7E</i>)	Free run, external Add RF Burst and frame	
RF burst trigger (<i>Option B7E</i>)		
Peak carrier power range ^a	30 to -25 dBm	30 to -30 dBm, typical
Preamp On (<i>Option 1DS</i>)	30 to -45 dBm	30 to -50 dBm, typical
Trigger level range	0 to -25 dB relative to signal peak	

a. With trigger level set to -6 dB.

	Specifications	Supplemental Information
Burst Sync (Requires <i>Option AYX or B7D</i>)		
Source (Actual available choices dependent on measurement) (<i>Option B7D and B7E</i>)	RF amplitude, none Add training sequence	
Training sequence code		GSM defined 0 to 7 Auto (search) or Manual
Burst type		Normal (TCH and CCH) Sync (SCH) Access (RACH)

General

	Specifications	Supplemental Information
Temperature Range		
Operating	0 to 55 °C	Floppy disk 10 to 40 °C
Storage	-40 to 75 °C	

	Specifications	Supplemental Information
Audible Noise (ISO 7779)		
Sound Pressure at 25 °C		<40 dBa, (<4.6 Bels power)

	Specifications	Supplemental Information
Military Specification	Has been type tested to the environmental specifications of MIL-PRF-28800F class 3.	

	Specifications	Supplemental Information
EMI Compatibility	Conducted and radiated emission is in compliance with CISPR Pub. 11/1990 Group 1 Class A.	
<i>(Option 060)^a</i>	Conducted and radiated emission is in compliance with CISPR Pub. 11/1990 Group 1 Class B ^b .	

- a. Option 060 is not compatible with Option B7B nor Option 1DP.
b. Meets Class A performance during dc operation.

	Specifications	Supplemental Information
Immunity Testing		
Radiated Immunity		Testing was done at 3 V/m according to IEC 801-3/1984. When the analyzer tuned frequency is identical to the immunity test signal frequency, there may be signals of up to -60 dBm displayed on the screen.

	Specifications	Supplemental Information
Electrostatic Discharge		Air discharges of up to 8 kV were applied according to IEC 801-2/1991. Discharges to center pins of any of the connectors may cause damage to the associated circuitry.

	Specifications	Supplemental Information
Power Requirements		
ac Operation		
Voltage, frequency	90 to 132 Vrms, 47 to 440 Hz 195 to 250 Vrms, 47 to 66 Hz	
Power Consumption, On	<300 W	
Power Consumption, Standby	<5 W	
dc Operation		
Voltage	12 to 20 Vdc	
Power Consumption	<200 W	
Power Consumption, Standby	<100 mW	

	Specifications	Supplemental Information
Measurement Speed		
Local Measurement and Display Update rate ^a		
Sweep points = 101		≥ 40/s, characteristic
Sweep points = 401		≥ 28/s, characteristic
Remote Measurement and GPIB Transfer Rate ^{b,c}		
(Option A4H)		
Sweep points = 101		≥ 40/s, characteristic
Sweep points =401		≥ 28/s, characteristic

	Specifications	Supplemental Information
RF Center Frequency Tune, Measure, and GPIB Transfer Time ^{b,d} (Option A4H)		
Sweep points = 101		≤ 75 ms, characteristic
Sweep points = 401		≤ 90 ms, characteristic

- Factory preset, auto align Off, segmented sweep Off, fixed center frequency, RBW = 1 MHz, spans >10 MHz and ≤600 MHz, and stop frequency ≤3 GHz.
- Display Off (:DISPlay:ENABLE OFF), and 32-bit integer data format (:FORMat:DATA INT,32), if *Option AYX* or *A4J* is installed, disable sweep ramp, (:SYSem:PORTs:IFVSWEEP:ENABLE OFF), markers Off, single sweep, measured with IBM compatible PC with 550 MHz Pentium® III running Windows® NT 4.0, one meter GPIB cable, National Instruments PCI-GPIB card and NI-488.2 DLL.
- Factory preset, auto align Off, segmented sweep Off, fixed center frequency, RBW = 1 MHz, and span = 20 MHz, fixed center frequency, stop frequency ≤3 GHz, average of 100 measurements.
- Factory preset, auto align Off, segmented sweep Off, RBW = 1 MHz, span= 20 MHz, stop frequency ≤3 GHz, center frequency tune step size = 50 MHz.

	Specifications	Supplemental Information
Data Storage		
Internal		200 Traces or States ^a
External (10 to 40 °C) 3.5" 1.44 MB, MS-DOS® compatible floppy disk		200 Traces or States ^a

- When storing traces set to 401 points.

	Specifications	Supplemental Information
Downloadable Program Memory <i>(Option B72)</i>		2 MB available memory 10 MB available memory

	Specifications	Supplemental Information
Demod Tune and Listen Demod <i>(Option BAA or 106)</i> <i>(Option A4J or AYW)</i> <i>(Option 106 or BAA)</i>	AM Add FM	Internal speaker, front-panel earphone jack and front-panel volume control. An uncalibrated demodulated signal is available on the AUX VIDEO OUT connector at the rear panel. An uncalibrated demodulated signal is available on the EXT VIDEO OUT connector at the rear panel.

	Specifications	Supplemental Information
Weight (without options) Net Shipping		17.1 kg (37.7 lb), characteristic 31.9 kg (70.3 lb), characteristic

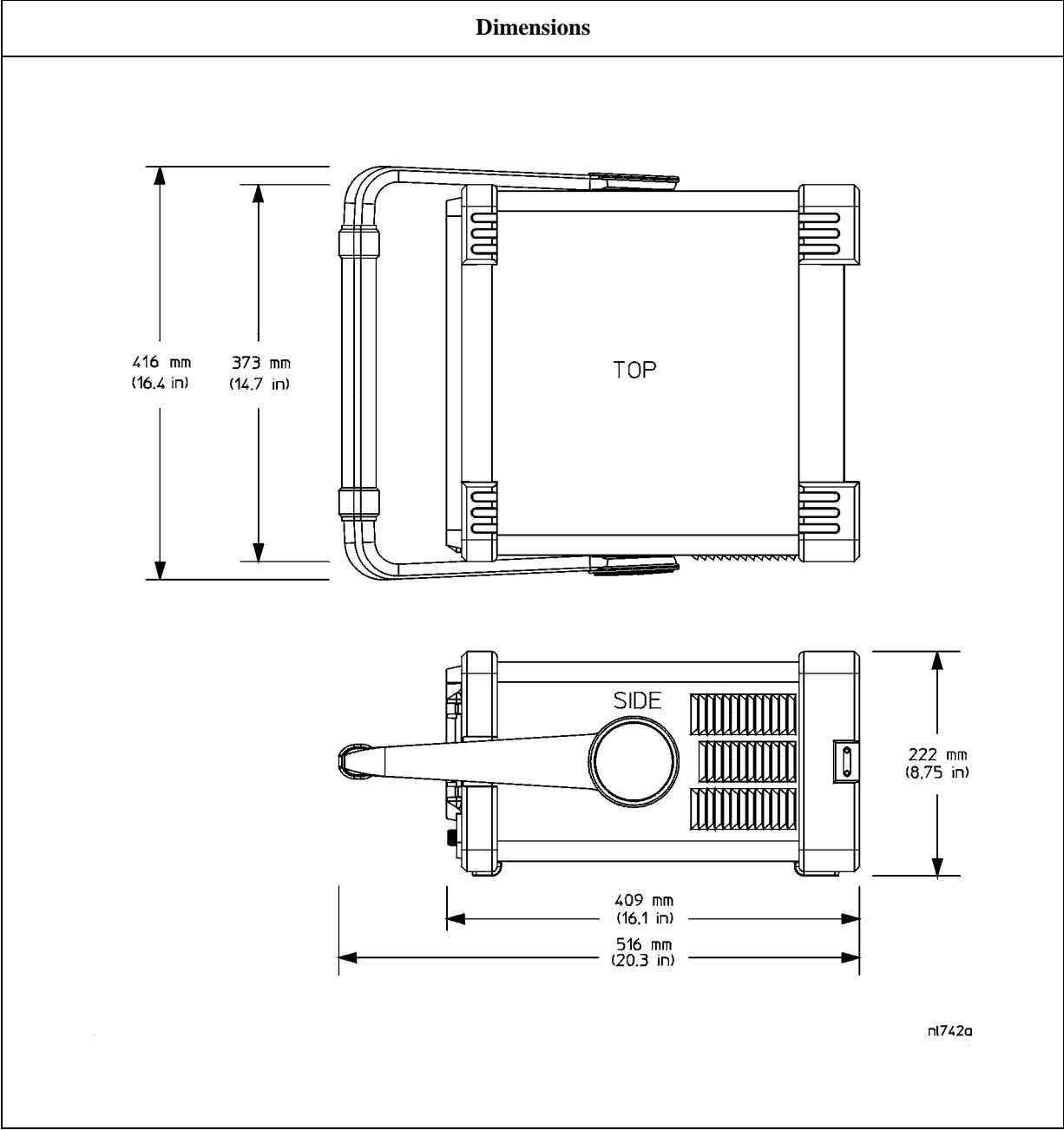

Inputs and Outputs

Front Panel

	Specifications	Supplemental Information
INPUT 50 Ω		
Connector	Type-N female	
Impedance		50 Ω , nominal

	Specifications	Supplemental Information
RF OUT 50 Ω, (Option 1DN)		
Connector	Type-N female	
Impedance		50 Ω , nominal

	Specifications	Supplemental Information
AMPTD REF OUT^a		Amplitude Reference
Connector	BNC female	
Impedance		50 Ω , nominal
Frequency		50 MHz
Frequency Accuracy		Frequency reference error ^b
50 Ω Amplitude ^c		-20 dBm, nominal

- Turn the amplitude reference on/off by pressing the keys: **Input/Output, Amptd Ref Out**.
- Frequency reference error = (aging rate \times period of time since adjustment + settability + temperature stability).
- The internal amplitude reference actual power is stored internally.

	Specifications	Supplemental Information
PROBE POWER		
Voltage/Current		+15 Vdc, $\pm 7\%$ at 150 mA max., characteristic -12.6 Vdc $\pm 10\%$ at 150 mA max., characteristic

	Specifications	Supplemental Information
EXT KEYBOARD^a		Used for entering screen titles and filenames only. Interface compatible with most IBM-compatible PC keyboards.
Connector	6-pin mini-DIN	

a. The feature is not implemented in firmware revisions prior to A.04.00.

	Specifications	Supplemental Information
Speaker		Front panel knob controls volume

	Specifications	Supplemental Information
Headphone		Front panel knob controls volume
Connector	3.5 mm (1/8 inch) miniature audio jack	
Power Output		0.2 W into 4 Ω , characteristic

Rear Panel

	Specifications	Supplemental Information
10 MHz REF OUT		
Connector	BNC female	
Impedance		50 Ω , nominal
Output Amplitude		>0 dBm, characteristic

	Specifications	Supplemental Information
10 MHz REF IN		
Connector	BNC female	Note: Analyzer noise sidebands and spurious response performance may be affected by the quality of the external reference used.
Impedance		50 Ω , nominal
Input Amplitude Range		-15 to +10 dBm, characteristic
Frequency		10 MHz, nominal

	Specifications	Supplemental Information
EXT REF IN (Option B7E)		
Connector	BNC, female	
Impedance		50 Ω , nominal
Input amplitude range	-5 to 10 dBm	
Frequency	1 to 30 MHz, selectable	
Frequency lock range	$\pm 5 \times 10^{-6}$ of specified external reference input frequency	

	Specifications	Supplemental Information
10 MHz OUT (Option B7E)		
Connector	BNC, female	
Impedance		50 Ω , nominal
Frequency		10 MHz, nominal
Level		0 dBm when Option 10 MHz Out is On

	Specifications	Supplemental Information
GATE TRIG/EXT TRIG IN		
Connector	BNC female	
External Trigger Input		
Trigger Level		Selectable positive or negative edge initiates sweep in EXT TRIG mode (5 V TTL)
Gate Trigger Input (Option 1D6)		
Minimum Pulse Width		>30 ns (5 V TTL)

	Specifications	Supplemental Information
GATE/HI SWP OUT		
Connector	BNC female	
High Sweep Output Level		High = sweep ^a ; Low = retrace (5 V TTL)
Gate Output (<i>Option 1D6</i>) Level		High = gate on; Low = gate off (5 V TTL)

a. High sweep may be high longer than the indicated sweep times.

	Specifications	Supplemental Information
VGA OUTPUT		
Connector	VGA compatible, 15-pin mini D-SUB	
Format		VGA (31.5 kHz horizontal, 60 Hz vertical sync rates, non-interlaced) Analog RGB
Resolution	640 × 480	

	Specifications	Supplemental Information
AUX IF OUT (<i>Option A4J or AYX</i>)		
Connector	BNC female	RBW ≥ 1 kHz
Frequency		21.4 MHz, nominal
Amplitude (for signal at reference level and for reference levels – input attenuation + preamp gain of –10 to –70 dBm)		–10 dBm (uncorrected), characteristic
Impedance		50 Ω, nominal

	Specifications	Supplemental Information
AUX VIDEO OUT (Option A4J or AYX)		RBW \geq 1 kHz
Connector	BNC female	
Amplitude Range (into >10 k Ω)		0 to 1 V (uncorrected), characteristic

	Specifications	Supplemental Information
HI SWP IN (Option A4J or AYX)		
Connector	BNC female	
Input		Open collector, low resets and holds the sweep (5 V TTL)

	Specifications	Supplemental Information
HI SWP OUT (Option A4J or AYX)		
Connector	BNC female	
Output		High = sweep ^a , Low = retrace (5 V TTL)

a. High sweep may be high longer than the indicated sweep times.

	Specifications	Supplemental Information
SWP OUT (Option A4J or AYX)		
Connector	BNC female	
Amplitude		0 to +10 V ramp, characteristic

	Specifications	Supplemental Information
PRESEL TUNE OUTPUT		
Connector	BNC female	
Load Impedance (dc coupled)		> 10 k Ω , nominal
Range		0 to +10 V, characteristic
Sensitivity		0.33 V/GHz of tuned frequency > 3 GHz, characteristic

Agilent E4405B Specifications and Characteristics
Inputs and Outputs

	Specifications	Supplemental Information
GPIB Interface (<i>Option A4H</i>)		
Connector	IEEE-488 bus connector	
GPIB Codes		SH1, AH1, T6, SR1, RL1, PP0, DC1, C1, C2, C3 and C28

	Specifications	Supplemental Information
Serial Interface (<i>Option IAX</i>)		
Connector	9-pin D-SUB male	RS-232

	Specifications	Supplemental Information
Parallel Interface (<i>Option A4H or IAX</i>)		
Connector	25-pin D-SUB female	Printer port only

	Specifications	Supplemental Information
EXT VIDEO IN/TV TRIG OUT ^a (<i>Option B7B or BAA</i>)		
Connector	BNC Female (75 Ω)	EXT VIDEO IN is the Baseband composite video input for TV trigger and picture on screen. TV TRIG OUT is the TV trigger output.
Impedance		75 Ω, nominal
(<i>Option BAA without Option B7B</i>)		Feature not implemented
(<i>Option BAA with Option B7B</i>)		
External Video Input Video Amplitude		1 V _{p-p} , nominal, characteristic
TV Trigger Output		Positive edge indicates start of selected TV line after sync. pulse
Amplitude		TTL (0 V and 3.4 V with 75 Ω series resistance), characteristic

- a. This connector is labelled EXT VIDEO IN on older spectrum analyzers and EXT VIDEO IN/TV TRIG OUT on newer spectrum analyzers.

	Specifications	Supplemental Information
EXT VIDEO OUT <i>(Option B7B or BAA)</i> Connector Impedance <i>(Option BAA without Option B7B)</i> Amplitude <i>(Option BAA with Option B7B)</i> Amplitude TV Source: SA TV Source and EXT VIDEO IN <i>(Option 106)</i> Connector Impedance Amplitude	BNC female (75 Ω) BNC female (75 Ω)	Baseband video output RBW ≥ 1 kHz 75 Ω, nominal 0 to 1 V (uncorrected), characteristic 0 to 1 V (uncorrected), characteristic Same as level at EXT VIDEO IN/TV TRIG OUT, characteristic 75 Ω, nominal 0 to 1 V (uncorrected), characteristic

	Specifications	Supplemental Information
EXT FRAME SYNC <i>(Option B7D)</i> Connector Level	BNC, female	5 V TTL

Regulatory Information

CAUTION

This product is designed for use in Installation Category II and Pollution Degree 2 per IEC 1010 and 664 respectively.

NOTE

This product has been designed and tested in accordance with IEC Publication 1010, Safety Requirements for Electronic Measuring Apparatus, and has been supplied in a safe condition. The instruction documentation contains information and warnings which must be followed by the user to ensure safe operation and to maintain the product in a safe condition.



The CE mark is a registered trademark of the European Community (if accompanied by a year, it is the year when the design was proven).



The CSA mark is the Canadian Standards Association safety mark.

ISM 1-A

This is a symbol of an Industrial Scientific and Medical Group 1 Class A product. (CISPR 11, Clause 4)

Declaration of Conformity

DECLARATION OF CONFORMITY	
According to ISO/IEC Guide 22 and CEN/CENELEC EN 45014	
Manufacturer's Name:	Agilent Technologies, Inc.
Manufacturer's Address:	1400 Fountaingrove Parkway Santa Rosa, CA 95403-1799 USA
Declares that the products	
Product Name:	Spectrum Analyzer
Model Number:	E4401B, E4402B, E4403B, E4404B, E4405B, E4407B, E4408B, E4411B
Product Options:	This declaration covers all options of the above products.
Conform to the following product specifications:	
EMC: IEC 61326-1:1997+A1:1998 / EN 61326-1:1997+A1:1998	
<u>Standard</u>	<u>Limit</u>
CISPR 11:1990 / EN 55011-1991	Group 1, Class A
IEC 61000-4-2:1995+A1998 / EN 61000-4-2:1995	4 kV CD, 8 kV AD
IEC 61000-4-3:1995 / EN 61000-4-3:1995	3 V/m, 80 - 1000 MHz
IEC 61000-4-4:1995 / EN 61000-4-4:1995	0.5 kV sig., 1 kV power
IEC 61000-4-5:1995 / EN 61000-4-5:1996	0.5 kV L-L, 1 kV L-G
IEC 61000-4-6:1996 / EN 61000-4-6:1998	3 V, 0.15 – 80 MHz
IEC 61000-4-11:1994 / EN 61000-4-11:1998	1 cycle, 100%
Safety: IEC 61010-1:1990 + A1:1992 + A2:1995 / EN 61010-1:1993 +A2:1995 CAN/CSA-C22.2 No. 1010.1-92	
Supplementary Information: The products herewith comply with the requirements of the Low Voltage Directive 73/23/EEC and the EMC Directive 89/336/EEC and carry the CE-marking accordingly.	
	
Santa Rosa, CA, USA	17 April 2000
Greg Pfeiffer/Quality Engineering Manager	
For further information, please contact your local Agilent Technologies sales office, agent or distributor.	

5 **Agilent E4407B Specifications and
Characteristics**

About This Chapter

This chapter contains specifications and characteristics for the Agilent E4407B spectrum analyzer. The distinction between specifications and characteristics is described as follows.

- Specifications describe the performance of parameters covered by the product warranty. (The temperature range is 0 °C to 55 °C, unless otherwise noted.)
- Characteristics describe product performance that is useful in the application of the product, but is not covered by the product warranty.
- Typical performance describes additional product performance information that is not covered by the product warranty. It is performance beyond specification that 80% of the units exhibit with a 95% confidence level over the temperature range 20 to 30 °C. Typical performance does not include measurement uncertainty.
- Nominal values indicate the expected performance, or describe product performance that is useful in the application of the product, but is not covered by the product warranty.

The following conditions must be met for the analyzer to meet its specifications.

- o The analyzer is within the one year calibration cycle.
- o If **Auto Align All** is selected:
 - After 2 hours of storage within the operating temperature range.
 - 5 minutes after the analyzer is turned on with sweep times less than 4 seconds.
 - After the front-panel amplitude reference is connected to the INPUT, and **Align Now RF** has been run, after the analyzer is turned on. And, once every 24 hours, or if ambient temperature changes more than 30 °C¹.
- o If **Auto Align Off** is selected:
 - When the analyzer is at a constant temperature, within the operating temperature range, for a minimum of 90 minutes.
 - After the analyzer is turned on for a minimum of 90 minutes, the front panel amplitude reference has been connected to the INPUT, and **Align Now All** has been run.
 - When **Align Now All** is run:
 - Every hour
 - If the ambient temperature changes more than 3 °C

1. 10 °C if Preamp (*Option IDS*) is active.

- If the 10 MHz reference changes
- When **Align Now RF** is run (with the front-panel amplitude reference connected to the INPUT):
 - Every 24 hours
 - If the ambient temperature changes more than 30 °C¹
- o If **Auto Align All but RF** is selected:
 - When the analyzer is at a constant temperature, within the operating temperature range, for a minimum of 90 minutes.
 - After the analyzer is turned on for a minimum of 90 minutes, the front panel amplitude reference has been connected to the INPUT, and **Align Now RF** has been run.
 - When **Align Now RF** is run (with the front-panel amplitude reference connected to the INPUT):
 - Every hour
 - If the ambient temperature changes more than 3 °C

1. 10 °C if Preamp (*Option 1DS*) is active.

Frequency

	Specifications	Supplemental Information	
Frequency Range	9 kHz to 26.5 GHz		
dc coupled	100 Hz to 26.5 GHz	30 Hz to 26.5 GHz, characteristic	
ac coupled	10 MHz to 26.5 GHz		
Band		Harmonic Mixing Mode (N ^a)	
0 (0 Hz to 3.0 GHz)		1-	
1 (2.85 GHz to 6.7 GHz)		1-	
2 (6.2 GHz to 13.2 GHz)		2-	
3 (12.8 GHz to 19.2 GHz)		4-	
4 (18.7 GHz to 26.5 GHz)		4-	
Preamp On (Option IDS)	1 MHz to 3.0 GHz		
(Option UKB)			
dc coupled	1 MHz to 3.0 GHz		
ac coupled	10 MHz to 3.0 GHz		
External Mixing (Option AYZ)	18 GHz to 325 GHz		
		Harmonic Mixing Mode (N ^a)	
Band		Preselected	Unpreselected
K (18.0 GHz to 26.5 GHz)		n/a	6-
A (26.5 GHz to 40.0 GHz)		8+	8-
Q (33.0 GHz to 50.0 GHz)		10+	10-
U (40.0 GHz to 60.0 GHz)		10+	10-
V (50.0 GHz to 75.0 GHz)		14+	14-
E (60.0 GHz to 90.0 GHz)		n/a	16-
W (75.0 GHz to 110.0 GHz)		n/a	18-
F (90.0 GHz to 140.0 GHz)		n/a	20-
D (110.0 GHz to 170.0 GHz)		n/a	24-
G (140.0 GHz to 220.0 GHz)		n/a	32-
Y (170.0 GHz to 260.0 GHz)		n/a	38-

	Specifications	Supplemental Information	
J (220.0 GHz to 325.0 GHz)		n/a	46–

- a. N is the harmonic mixing mode. For negative mixing modes (as indicated by the “–”), the desired 1st LO harmonic is higher than the tuned frequency by the 1st IF (3.9214 for the 9 kHz to 3 GHz band, 321.4 MHz for all other bands) For positive mixing modes, the desired 1st LO harmonic is lower than the tuned frequency by 321.4 MHz.

	Specifications	Supplemental Information
Frequency Reference		
Aging Rate	$\pm 2 \times 10^{-6}$ /year	$\pm 1.0 \times 10^{-7}$ /day, characteristic
Settability	$\pm 5 \times 10^{-7}$	
Temperature Stability	$\pm 5 \times 10^{-6}$	

	Specifications	Supplemental Information
High Stability Frequency Reference (Option 1D5)		
Aging Rate	$\pm 1 \times 10^{-7}$ /year	$\pm 5 \times 10^{-10}$ /day, 7-day average after being powered on for 7 days, characteristic
Settability	$\pm 1 \times 10^{-8}$	
Temperature Stability		
20 to 30 °C	$\pm 1 \times 10^{-8}$	
0 to 55 °C	$\pm 5 \times 10^{-8}$	
Warm-up (Internal frequency reference selected)		
After 5 minutes		$< \pm 1 \times 10^{-7}$ of final frequency, ^a characteristic
After 15 minutes		$< \pm 1 \times 10^{-8}$ of final frequency, ^a characteristic

- a. Final frequency is defined as frequency 60 minutes after power-on with analyzer set to internal frequency reference.

	Specifications	Supplemental Information
Frequency Readout Accuracy (Start, Stop, Center, Marker)	$\pm((\text{frequency indication} \times \text{frequency reference error}^{\text{a}}) + 0.5\% \text{ of span} + \frac{\text{span}}{\text{sweep points} - 1} + 15\% \text{ of RBW} + 10 \text{ Hz} + 1 \text{ Hz} \times \text{N}^{\text{b}})$	

- a. Frequency reference error = (aging rate \times period of time since adjustment + settability + temperature stability).
b. N is the harmonic mixing mode.

	Specifications	Supplemental Information
Marker Frequency Counter		
Resolution	Selectable from 1 Hz to 100 kHz	
Accuracy ^a	$\pm(\text{marker frequency} \times \text{frequency reference error}^{\text{b}} + \text{counter resolution})^{\text{c}}$	For RBW \geq 1 kHz

- a. Marker level to displayed noise level $>$ 25 dB, RBW/ Span \geq 0.002, frequency offset = 0 Hz.
b. Frequency reference error = (aging rate \times period of time since adjustment + settability + temperature stability).
c. For firmware revisions prior to A.03.00, add 1 Hz \times N, where N is the harmonic mixing mode.

	Specifications	Supplemental Information
Frequency Span		
Range		
Internal Mixing	0 Hz (zero span), 100 Hz to 26.5 GHz	
External Mixing (Option AYZ)	0 Hz (zero span), Minimum span = 100 Hz	
Resolution	$2 \text{ Hz} \times \text{N}^{\text{a}}$	
Accuracy ^b	$\pm(0.5\% \text{ of span} + 2 \times \frac{\text{span}}{\text{sweep points} - 1})$	

- a. N is the harmonic mixing mode.
b. Applies to each sweep segment.

	Specifications	Supplemental Information
Sweep Time		
Range		
Span > 0 Hz	1 ms to 4000 s ^a	$\frac{\text{sweep points} - 1}{100 \text{ kHz}}$ to 4000 s
Span = 0 Hz	10 μs to 4000 s ^{a,b}	
Tracking Generator On (Option 1DN)		50 ms is the minimum sweep time
Fast Time-domain Sweep (Option AYX) (For Span = 0 Hz, RBW ≥ 1 kHz)	50 ns to 4000 s ^{c,d}	$\frac{\text{sweep points} - 1}{20 \text{ MHz}}$ to 4000 s
DSP and fast ADC (Option B7D) (For Span = 0 Hz, RBW ≥ 1 kHz)	25 ns to 4000 s ^e	$\frac{\text{sweep points} - 1}{40 \text{ MHz}}$ to 4000 s
Accuracy (Span = 0 Hz)		
10 μs to 4000 s ^{a,b}	±1%	
(Option AYX)	±1%	
50 ns to 4000 s ^{c,d}		
(Option B7D)	±1%	
25 ns to 4000 s ^e		
Sweep Trigger ^{f,g}		
	Free Run, Single, Line, Video ^h , External, Delayed, Offset ⁱ	
(Option 1D6)	Add Gate	
(Option B7B)	Add TV	
Delayed Trigger ^{g,j}		
Range	1 μs to 400 s	
Resolution	$\frac{\text{delay in seconds}}{65000}$ rounded up to nearest μs	
Accuracy	±(500 ns + (0.01% of delay))	
Offset Trigger ⁱ		
Resolution	$\frac{\text{sweep time}}{\text{sweep points} - 1}$	

	Specifications	Supplemental Information
Range	± 327 ms to ± 12.3 ks	Where ST = sweep time and SP = sweep points $\frac{-32766 \times ST}{SP - 1}$ to $\frac{(32766 - SP) \times ST}{SP - 1}$
Fast Time-domain sweep (Option AYX) (For sweep times $\frac{\text{sweep points} - 1}{20 \text{ MHz}}$ to $\frac{\text{sweep points} - 1}{100 \text{ kHz}}$)	± 1.23 ms to ± 245 ms	$\frac{-32766 \times ST}{SP - 1}$ to $\frac{(32766 - SP) \times ST}{SP - 1}$
DSP and fast ADC (Option B7D) (For sweep times $\frac{\text{sweep points} - 1}{40 \text{ MHz}}$ to $\frac{\text{sweep points} - 1}{100 \text{ kHz}}$)	± 13 ms to ± 5.15 s	$\frac{-524031 \times ST}{SP - 1}$ to $\frac{(524031 - SP) \times ST}{SP - 1}$

- a. For firmware revisions prior to A.04.00, 5 ms to 2000 s.
- b. For firmware revisions prior to A.05.00, 1 ms to 4000 s.
- c. For firmware revisions prior to A.04.00, 20 μ s to 2000 s.
- d. For firmware revisions prior to A.05.00, 5 μ s to 4000 s.
- e. For firmware revisions prior to A.05.00, 2.5 μ s to 4000 s.
- f. Gate cannot be used simultaneously with delayed or TV trigger (Option B7B).
- g. Auto align is suspended in video, external, gate, and delayed trigger modes while waiting for a trigger event to occur.
- h. Unavailable when $RBW \leq 300$ Hz (Option IDR).
- i. For firmware revision A.04.00 or later.
- j. Delayed trigger is available with line, external trigger, and TV trigger (Option B7B).

	Specifications	Supplemental Information
Sweep (trace) Points		
Range		
Span > 0 Hz	101 to 8192 ^a	
Span = 0 Hz	2 to 8192 ^{a,b}	

- a. For firmware revisions prior to A.04.00, 401 points.
- b. For firmware revisions prior to A.05.00, 101 to 8192 points.

	Specifications	Supplemental Information
Resolution Bandwidth (RBW)		
Range		
–3 dB bandwidth	1 kHz to 3 MHz, in 1-3-10 sequence, 5 MHz	
–6 dB bandwidth (EMI)	9 kHz and 120 kHz	
<i>(Option 1DR)</i>		Only available in spans ≤ 5 MHz, sweep times $\geq \frac{\text{sweep points} - 1}{100 \text{ kHz}}$, and not usable with tracking generator on. <i>(Option 1DN)</i>
–3 dB bandwidth	Adds 10, 30, 100, 300 Hz	
–6 dB bandwidth (EMI)	Add 200 Hz	
Accuracy		
1 kHz to 3 MHz RBW	$\pm 15\%$	
5 MHz RBW	$\pm 30\%$	
10 Hz to 300 Hz RBW <i>(Option 1DR)</i>	$\pm 10\%$	
Shape		
1 kHz to 5 MHz RBW		Synchronously tuned four poles, approximately Gaussian shape
10 Hz to 300 Hz RBW <i>(Option 1DR)</i>		Digital, approximately Gaussian shape
Selectivity (60 dB/3 dB bandwidth ratio)		
1 kHz to 5 MHz RBW		$<15:1$, characteristic
10 Hz to 300 Hz RBW <i>(Option 1DR)</i>		$<5:1$, characteristic

	Specifications	Supplemental Information
Video Bandwidth (VBW) (-3 dB)		
Range	30 Hz to 1 MHz in 1-3-10 sequence	3 MHz, characteristic
(Option 1DR)	Adds 1, 3, 10 Hz for RBW's <1 kHz	
Accuracy		±30%, characteristic
Shape		Post detection, single pole low-pass filter used to average displayed noise Video bandwidths below 30 Hz are digital bandwidths with anti-aliasing filtering.

	Specifications	Supplemental Information
Stability		
Noise Sidebands (Offset from CW signal with 1 kHz RBW, 30 Hz VBW and sample detector)		
≥1 kHz (Option 1DR, 1D5)		≤ -78 dBc/Hz ^a , typical
≥10 kHz	≤ -90 dBc/Hz ^a	≤ -94 dBc/Hz ^a , typical
≥20 kHz	≤ -100 dBc/Hz ^a	≤ -105 dBc/Hz ^a , typical
≥30 kHz	≤ -106 dBc/Hz ^a	≤ -112 dBc/Hz ^a , typical
≥100 kHz	≤ -119 dBc/Hz ^a	≤ -122 dBc/Hz ^a , typical
≥1 MHz	≤ -125 dBc/Hz ^a	≤ -127 dBc/Hz ^a , typical
≥5 MHz	≤ -127 dBc/Hz ^a	≤ -129 dBc/Hz ^a , typical
≥10 MHz	≤ -131 dBc/Hz ^a	≤ -136 dBc/Hz ^a , typical
(Option 120)		
≥1 MHz	≤ -133 dBc/Hz ^a	≤ -136 dBc/Hz, typical
≥5 MHz	≤ -135 dBc/Hz ^a	≤ -139 dBc/Hz, typical
≥10 MHz	≤ -137 dBc/Hz ^a	≤ -141 dBc/Hz, typical
Residual FM		
1 kHz RBW, 1 kHz VBW	≤150 Hz × N p-p in 100 ms	

	Specifications	Supplemental Information
<p><i>(Option 1D5)</i></p> <p>10 Hz RBW, 10 Hz VBW <i>(Option 1DR and 1D5)</i></p> <p>10 Hz RBW, 10 Hz VBW <i>(Option 1DR)</i></p> <p>System-Related Sidebands, offset from CW signal</p> <p>≥30 kHz</p> <p>Line-Related Sidebands, offset from CW signal <i>(Option 1DR)</i></p> <p><300 Hz</p> <p>>300 Hz to 30 kHz</p>	<p>≤100 Hz × N p-p in 100 ms</p> <p>≤2 Hz × N p-p in 20 ms</p> <p>≤ -65 dBc^a</p>	<p>≤10 Hz × N p-p in 20 ms, characteristic</p> <p>≤ -50 dBc^a, characteristic</p> <p>≤ -55 dBc^a, characteristic</p>

a. Add 20 Log(N) for frequencies > 6.7 GHz

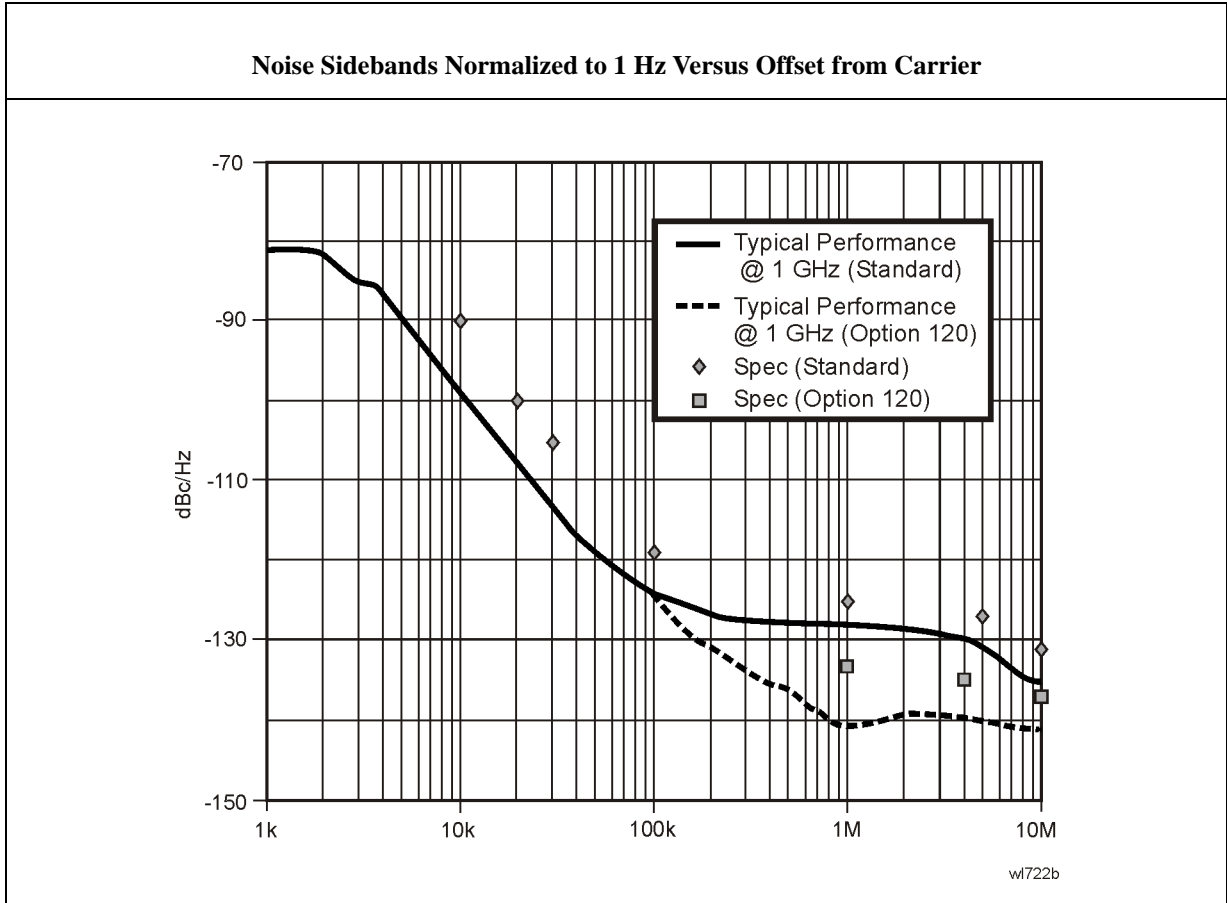

Amplitude

Amplitude specifications do not apply for the negative peak detector mode.

	Specifications	Supplemental Information
Measurement Range	Displayed Average Noise Level to Maximum Safe Input Level	
Input Attenuator Range	0 to 65 dB, in 5 dB steps	

	Specifications	Supplemental Information
Maximum Safe Input Level		
Average Continuous Power (Input attenuator setting ≥ 5 dB)	+30 dBm (1 W)	
Peak Pulse Power (for < 10 μ sec pulse width, $< 1\%$ duty cycle, and input attenuation ≥ 30 dB)	+50 dBm (100 W)	
dc	0 Vdc	
(Option UKB)		
dc coupled	0 Vdc	
ac coupled	50 Vdc	

	Specifications	Supplemental Information
1 dB Gain Compression		
Total power at input mixer ^{a,b}		
50 MHz to 3.0 GHz	0 dBm	
3.0 GHz to 6.7 GHz	0 dBm	
6.7 GHz to 13.2 GHz	-3 dBm	
13.2 GHz to 26.5 GHz	-5 dBm	
Preamp On (Option IDS)		
Total power at the preamp ^c		-20 dBm, characteristic

- Mixer power level (dBm) = input power (dBm) - input attenuation (dB).
- For resolution bandwidths 1 kHz to 30 kHz, the maximum input signal amplitude must be \leq reference level +10 dB.
- Total power at the preamp (dBm) = total power at the input (dBm) - input attenuation (dB).

	Specifications		Supplemental Information	
Displayed Average Noise Level (Input terminated, 0 dB attenuation, sample detector, Reference Level = -70 dBm)				
	1 kHz RBW 30 Hz VBW	10 Hz RBW 1 Hz VBW (Option IDR)	1 kHz RBW 30 Hz VBW (typical)	10 Hz RBW 1 Hz VBW (Option IDR) (typical)
9 kHz to 100 kHz				≤ -109 dBm
100 kHz to 1 MHz				≤ -135 dBm
1 MHz to 10 MHz			≤ -117 dBm	≤ -137 dBm
1 MHz to 10 MHz (Option 120)			≤ -120 dBm	≤ -139 dBm
10 MHz to 1.0 GHz	≤ -116 dBm	≤ -135 dBm	≤ -119 dBm	≤ -139 dBm
1.0 GHz to 2.0 GHz	≤ -116 dBm	≤ -135 dBm	≤ -120 dBm	≤ -140 dBm
2.0 GHz to 3.0 GHz	≤ -112 dBm	≤ -131 dBm	≤ -118 dBm	≤ -138 dBm
3.0 GHz to 6.0 GHz	≤ -112 dBm	≤ -131 dBm	≤ -118 dBm	≤ -138 dBm
6.0 GHz to 12 GHz	≤ -111 dBm	≤ -130 dBm	≤ -117 dBm	≤ -137 dBm
12 GHz to 22 GHz	≤ -107 dBm	≤ -126 dBm	≤ -114 dBm	≤ -134 dBm
22 GHz to 26.5 GHz	≤ -106 dBm	≤ -125 dBm	≤ -112 dBm	≤ -132 dBm
Preamp On (Option IDS)	1 kHz RBW 30 Hz VBW	10 Hz RBW 1 Hz VBW (Option IDR)	1 kHz RBW 30 Hz VBW (typical)	10 kHz RBW 1 Hz VBW (Option IDR) (typical)
0 to 55 °C				
10 MHz to 1.0 GHz	≤ -131 dBm	≤ -150 dBm		
1.0 GHz to 2.0 GHz	≤ -131 dBm	≤ -150 dBm		
2.0 GHz to 3.0 GHz	≤ -127 dBm	≤ -146 dBm		
20 to 30 °C				
1 MHz to 10 MHz (Option UKB) (dc coupled)			≤ -135 dBm	≤ -155 dBm
10 MHz to 1.0 GHz	≤ -132 dBm	≤ -151 dBm	≤ -137 dBm	≤ -157 dBm
1.0 GHz to 2.0 GHz	≤ -132 dBm	≤ -151 dBm	≤ -135 dBm	≤ -155 dBm
2.0 GHz to 3.0 GHz	≤ -130 dBm	≤ -149 dBm	≤ -132 dBm	≤ -152 dBm

	Specifications		Supplemental Information	
External Mixing (<i>Option AYZ</i>)			1 kHz RBW 30 Hz VBW ≤ -134 dBm + external mixer conversion loss, characteristic	10 Hz RBW 1 Hz VBW (<i>Option IDR</i>) ≤ -153 dBm + external mixer conversion loss, characteristic

	Specifications		Supplemental Information	
Display Range				
Log Scale		Ten divisions displayed; 0.1, 0.2, 0.5 dB/division and 1 to 20 dB/division in 1 dB steps		
RBW ≥ 1 kHz		Calibrated 0 to -85 dB from Reference Level		
RBW ≤ 300 Hz (<i>Option IDR</i>)		Calibrated 0 to -120 dB ^a from Reference Level		
Linear Scale		Ten divisions		
Scale Units		dBm, dBmV, dB μ V, dB μ A, A, V, and W		
(<i>Option BAA, 106</i>)		Add Hz		

- a. 0 to -70 dB range when span = 0 Hz, or when IF Gain fixed:
(:DISPlay:WINDow:TRACe:Y[:SCALe]:LOG:RANGe:AUTO OFF).

	Specifications		Supplemental Information	
Marker Readout Resolution				
Log scale				
RBW ≥ 1 kHz		0 to -85 dB from ref level	0.04 dB	
RBW ≤ 300 Hz (<i>Option IDR</i>)		0 to -120 dB from ref level	0.04 dB	
Linear scale			0.01% of Reference Level	

	Specifications	Supplemental Information
<p>Fast Sweep Times for Zero Span</p> <p><i>(Option AXX)^a</i> For sweep times $\frac{\text{sweep points} - 1}{20 \text{ MHz}}$ to $\frac{\text{sweep points} - 1}{100 \text{ kHz}}$</p> <p>Log 0 to -85 dB from ref level</p> <p>Linear</p> <p><i>(Option B7D)</i> For sweep times $\frac{\text{sweep points} - 1}{40 \text{ MHz}}$ to $\frac{\text{sweep points} - 1}{100 \text{ kHz}}$</p> <p>Log 0 to -85 dB from ref level</p> <p>Linear</p>	<p>0.3 dB</p> <p>0.3% of Reference Level for linear scale</p> <p>0.2 dB</p> <p>0.2% of Reference Level for linear scale</p>	

a. For firmware revisions prior to A.04.00, 20 μ s to <5 ms.

	Specifications	Supplemental Information
<p>Frequency Response</p> <p>Absolute^a/Relative</p> <p>10 dB attenuation</p> <p>9 kHz to 3.0 GHz</p> <p>20 to 30 °C</p> <p>0 to 55 °C</p> <p>800 MHz to 1.0 GHz</p> <p>20 to 30 °C</p> <p>0 to 55 °C</p>	<p>± 0.46 dB</p> <p>± 0.76 dB</p> <p>± 0.46 dB</p> <p>± 0.76 dB</p>	<p>± 0.14 dB, typical</p> <p>± 0.10 dB, typical</p>

	Specifications	Supplemental Information
1.7 GHz to 2.0 GHz		
20 to 30 °C	±0.46 dB	±0.08 dB, typical
0 to 55 °C	±0.76 dB	
<i>(Option UKB)</i> (dc coupled)		
100 Hz to 3.0 GHz		
20 to 30 °C	±0.5 dB	
0 to 55 °C	±1.0 dB	
30 Hz to 3.0 GHz		
20 to 30 °C		±0.5 dB, characteristic
0 to 55 °C		±1.0 dB, characteristic
(ac coupled)		
10 MHz to 3.0 GHz		
20 to 30 °C	±0.5 dB	
0 to 55 °C	±1.0 dB	
800 MHz to 1.0 GHz		
20 to 30 °C	±0.5 dB	
0 to 55 °C	±1.0 dB	
1.7 GHz to 2.0 GHz		
20 to 30 °C	±0.5 dB	
0 to 55 °C	±1.0 dB	
Absolute ^a /Relative Preamp On <i>(Option IDS)</i>		
0 dB attenuation		
1 MHz to 3.0 GHz		
20 to 30 °C	±1.5 dB	±0.47 dB, typical
0 to 55 °C	±2.0 dB	
800 MHz to 1.0 GHz		
20 to 30 °C	±1.5 dB	±0.35 dB, typical
0 to 55 °C	±2.0 dB	
1.7 GHz to 2.0 GHz		

	Specifications	Supplemental Information
20 to 30 °C	±1.5 dB	±0.26 dB, typical
0 to 55 °C	±2.0 dB	
<i>(Option UKB)</i> (dc coupled)		
1 MHz to 3.0 GHz		
20 to 30 °C	±1.5 dB	±0.47 dB, typical
0 to 55 °C	±2.0 dB	
(ac coupled)		
10 MHz to 3.0 GHz		
20 to 30 °C	±1.5 dB	
0 to 55 °C	±2.0 dB	
800 MHz to 1.0 GHz		
20 to 30 °C	±1.5 dB	±0.35 dB, typical
0 to 55 °C	±2.0 dB	
1.7 GHz to 2.0 GHz		
20 to 30 °C	±1.5 dB	±0.26 dB, typical
0 to 55 °C	±2.0 dB	
Preselector centered for frequency >3.0 GHz <i>(Option UKB)</i> (ac or dc coupled)		
10 dB attenuation		
3.0 GHz to 6.7 GHz		
Absolute ^a		
20 to 30 °C	±1.5 dB	±0.38 dB, typical
0 to 55 °C	±2.5 dB	
Relative		
20 to 30 °C	±1.3 dB	
0 to 55 °C	±1.5 dB	

	Specifications	Supplemental Information
6.7 GHz to 13.2 GHz		
Absolute ^a		
20 to 30 °C	±2.0 dB	±0.68 dB, typical
0 to 55 °C	±3.0 dB	
Relative		
20 to 30 °C	±1.8 dB	
0 to 55 °C	±2.0 dB	
13.2 GHz to 26.5 GHz		
Absolute ^a		
20 to 30 °C	±2.0 dB	±0.86 dB, typical
0 to 55 °C	±3.0 dB	
Relative		
20 to 30 °C	±1.8 dB	
0 to 55 °C	±2.0 dB	

a. Absolute frequency response values are referenced to the amplitude at 50 MHz.

	Specifications	Supplemental Information
Input Attenuation Switching Uncertainty at 50 MHz		
Attenuator Setting		
0 dB to 5 dB	±0.3 dB	
10 dB	Reference	
15 dB	±0.3 dB	
20 to 65 dB attenuation	±(0.1 dB + 0.01 × Attenuator Setting)	

Attenuation Accuracy Relative to the 10 dB Attenuator Setting, Characteristic					
Attenuation	Frequency Range				
	dc–3 GHz	3.0–13.2 GHz	13.2–19 GHz	19–22 GHz	22–26.5 GHz
0 dB	±0.3 dB	±0.5 dB	±0.8 dB	±0.9 dB	±1.0 dB
5 dB	±0.3 dB	±0.5 dB	±0.8 dB	±0.9 dB	±1.0 dB
10 dB	Reference	Reference	Reference	Reference	Reference
15 dB	±0.4 dB	±0.5 dB	±0.8 dB	±1.0 dB	±1.5 dB
20 dB	±0.4 dB	±0.5 dB	±0.8 dB	±1.0 dB	±1.5 dB
25 dB	±0.5 dB	±0.6 dB	±0.8 dB	±1.2 dB	±2.0 dB
30 dB	±0.5 dB	±0.6 dB	±0.8 dB	±1.2 dB	±2.0 dB
35 dB	±0.6 dB	±0.7 dB	±1.0 dB	±1.8 dB	±3.0 dB
40 dB	±0.6 dB	±0.7 dB	±1.0 dB	±1.8 dB	±3.0 dB
45 dB	±0.7 dB	±1.0 dB	±1.3 dB	±2.2 dB	±3.4 dB
50 dB	±0.7 dB	±1.0 dB	±1.3 dB	±2.2 dB	±3.4 dB
55 dB	±0.9 dB	±1.1 dB	±1.6 dB	±2.7 dB	±3.5 dB
60 dB	±0.9 dB	±1.1 dB	±1.6 dB	±2.7 dB	±3.5 dB
65 dB	±1.0 dB	±1.6 dB	±2.0 dB	±3.2 dB	±3.8 dB

	Specifications	Supplemental Information
Preamp (<i>Option 1DS</i>)		Refer also to Displayed Average Noise Level specification
Gain		+20 dB, nominal ^a
Noise figure		5 dB, characteristic

a. Amplifier is between the input attenuator and the input mixer.

	Specifications	Supplemental Information
Absolute Amplitude Accuracy		
At reference settings ^a	±0.34 dB	±0.13 dB, typical
Preamp On ^b (<i>Option IDS</i>)	±0.37 dB	±0.14 dB, typical
External Mixing (<i>Option AYZ</i>)	IF INPUT absolute amplitude accuracy + external mixer conversion loss accuracy ^c	
Overall Amplitude Accuracy ^d		
20 to 30 °C	± (0.54 dB + Absolute Frequency Response)	

- Settings are: reference level -20 dBm; input attenuation 10 dB; dc coupled (*Option UKB*); center frequency 50 MHz; RBW 1 kHz; VBW 1 kHz; scale linear or log; span 2 kHz; sweep time coupled, sample detector, signal at reference level.
- Settings are: reference level -30 dBm; input attenuation 0 dB; dc coupled (*Option UKB*); center frequency 50 MHz; RBW 1 kHz; VBW 1 kHz; scale linear or log; span 2 kHz; sweep time coupled, signal at reference level.
- Preselector centered with HP/Agilent 11974-Series mixers.
- For reference level 0 to -50 dBm; input attenuation 10 dB; dc coupled (*Option UKB*); RBW 1 kHz; VBW 1 kHz; scale log, log range 0 to -50 dB from reference level; sweep time coupled; signal input 0 to -50 dBm; span ≤20 kHz; internal mixing.

	Specifications	Supplemental Information
RF Input VSWR (at tuned frequency)		
Attenuator setting 0 dB		
9 kHz to 26.5 GHz		≤3.0:1, characteristic
Attenuator setting 5 dB		
9 kHz to 100 kHz		≤2.0:1, characteristic
100 kHz to 6.7 GHz		≤1.4:1, characteristic
6.7 GHz to 13.2 GHz		≤1.7:1, characteristic
13.2 GHz to 22.0 GHz		≤2.3:1, characteristic
22.0 GHz to 26.5 GHz		≤2.6:1, characteristic

	Specifications	Supplemental Information	
Attenuator setting 10 to 65 dB			
9 kHz to 6.7 GHz		≤1.3:1, characteristic	
6.7 GHz to 13.2 GHz		≤1.5:1, characteristic	
13.2 GHz to 22.0 GHz		≤2.0:1, characteristic	
22.0 GHz to 26.5 GHz		≤2.2:1, characteristic	
<i>(Option UKB)</i>		characteristic	characteristic
Attenuator setting 0 dB		(dc coupled)	(ac coupled)
100 Hz to 100 kHz		≤1.1:1	
100 kHz to 3 GHz		≤3.0:1	≤3.0:1
100 kHz to 6.7 GHz		≤1.4:1, characteristic	
6.7 GHz to 13.2 GHz		≤1.7:1, characteristic	
13.2 GHz to 22.0 GHz		≤2.3:1, characteristic	
22.0 GHz to 26.5 GHz		≤2.6:1, characteristic	
Attenuator setting 5 dB		(dc coupled)	(ac coupled)
100 Hz to 100 kHz		≤1.1:1	
100 kHz to 300 kHz		≤1.1:1	≤2.3:1
300 kHz to 1.0 MHz		≤1.1:1	≤1.6:1
1.0 MHz to 3.0 GHz		≤1.4:1	≤1.4:1
100 kHz to 6.7 GHz		≤1.4:1, characteristic	
6.7 GHz to 13.2 GHz		≤1.7:1, characteristic	
13.2 GHz to 22.0 GHz		≤2.3:1, characteristic	
22.0 GHz to 26.5 GHz		≤2.6:1, characteristic	

	Specifications	Supplemental Information	
Attenuator setting 10 to 65 dB		(dc coupled)	(ac coupled)
100 Hz to 100 kHz		≤1.1:1	
100 kHz to 300 kHz		≤1.1:1	≤2.1:1
300 kHz to 1.0 MHz		≤1.1:1	≤1.5:1
1.0 MHz to 3.0 GHz		≤1.2:1	≤1.2:1
100 kHz to 6.7 GHz		≤1.4:1, characteristic	
6.7 GHz to 13.2 GHz		≤1.7:1, characteristic	
13.2 GHz to 22.0 GHz		≤2.3:1, characteristic	
22.0 GHz to 26.5 GHz		≤2.6:1, characteristic	

	Specifications	Supplemental Information
Auto Alignment^a		
Sweep-to-sweep variation		±0.1 dB, characteristic

a. Set **Auto Align** to **Off** and use **Align Now, All** to eliminate this variation.

	Specifications	Supplemental Information
Resolution Bandwidth Switching Uncertainty (at Reference Level)		
1 kHz RBW	Reference	
3 kHz to 3 MHz RBW	±0.3 dB	
5 MHz RBW	±0.6 dB	
10 Hz to 300 Hz RBW (Option 1DR)	±0.3 dB	

	Specifications	Supplemental Information
Reference Level		
Range	-149.9 dBm to maximum mixer level + attenuator setting	
Resolution		
Log Scale	±0.1 dB	
Linear Scale	±0.12% of Reference Level	
Accuracy (at a fixed frequency, a fixed attenuator, and referenced to -30 dBm (-10 dBm, Preamp On (<i>Option 1DS</i>)))		
Reference Level (dBm) – input attenuator setting (dB) + preamp gain (dB)		
-10 dBm to > -60 dBm	±0.3 dB	
-60 dBm to > -85 dBm	±0.5 dB	
-85 dBm to -90 dBm	±0.7 dB	

	Specifications	Supplemental Information
Display Scale Switching Uncertainty		
Switching between Linear and Log	±0.15 dB at reference level	
Log Scale Switching	No error	

	Specifications	Supplemental Information
Display Scale Fidelity		
Log Maximum Cumulative		
RBW ≥ 1 kHz		
dB Below Reference Level		
0 dB Reference	0 dB	
> 0 to 10 dB	±0.22 dB	±0.08 dB, typical
> 10 to 20 dB	±0.24 dB	±0.09 dB, typical
> 20 to 30 dB	±0.26 dB	±0.10 dB, typical
> 30 to 40 dB	±0.40 dB	±0.23 dB, typical

	Specifications	Supplemental Information
> 40 to 50 dB	±0.57 dB	±0.35 dB, typical
> 50 to 60 dB	±0.57 dB	±0.35 dB, typical
> 60 to 70 dB	±0.66 dB	±0.39 dB, typical
>70 to 80 dB	±0.66 dB	±0.46 dB, typical
>80 to 85 dB	±1.15 dB	±0.79 dB, typical
RBW ≤ 300 Hz (<i>Option IDR</i>)		
Span > 0 Hz		
Auto range On		
0 to 98 dB below reference level	±(0.3 dB + 0.01 × dB from reference level)	±2.0 dB, characteristic
> 98 to 120 dB below reference level		
Auto range Off		
0 to 60 dB below reference level	±(0.3 dB + 0.015 × dB from reference level)	
> 60 to 70 dB below reference level	±1.5 dB	
Span = 0 Hz ^a		
0 to 60 dB below reference level	±(0.3 dB + 0.015 × dB from reference level)	
> 60 to 70 dB below reference level	±1.5 dB	
Log Incremental Accuracy		
0 to 80 dB ^b below reference level	±0.4 dB/4 dB	
Linear Accuracy		
	±2% of Reference Level	

- a. The SCPI command for auto range off is:
(:DISPlay:WINDow:TRACe:Y[:SCALe]:LOG:RANGe:AUTO OFF)
- b. 0 to -50 dB for RBWs ≤ 300 Hz and span = 0 Hz, or when auto ranging is off.

	Specifications	Supplemental Information
Spurious Responses		
Second Harmonic Distortion		
Input Signal		
10 MHz to 500 MHz	< -65 dBc for -30 dBm signal at input mixer ^a	+35 dBm SHI (second harmonic intercept)
500 MHz to 1.5 GHz	< -75 dBc for -30 dBm signal at input mixer ^a	+45 dBm SHI
1.5 GHz to 2.0 GHz	< -85 dBc for -10 dBm signal at input mixer ^a	+75 dBm SHI
2.0 GHz to 3.35 GHz	< -100 dBc ^b for -10 dBm signal at input mixer ^a	+90 dBm SHI
3.35 GHz to 6.6 GHz	< -100 dBc ^b for -10 dBm signal at input mixer ^a	+90 dBm SHI
6.6 GHz to 13.25 GHz	< -100 dBc ^b for -10 dBm signal at input mixer ^a	+90 dBm SHI
Preamp On (<i>Option 1DS</i>) 10 MHz to 1.5 GHz		-5 dBm SHI, characteristic
Third Order Intermodulation Distortion		
10 MHz to 100 MHz		+7 dBm TOI (third order intercept), characteristic
100 MHz to 3 GHz	< -85 dBc for two -30 dBm signals at input mixer ^a and >50 kHz separation	+12.5 dBm TOI +16 dBm TOI, typical
3.0 GHz to 6.7 GHz	< -82 dBc for two -30 dBm signals at input mixer ^a and >50 kHz separation	+11 dBm TOI +18 dBm TOI, typical
6.7 GHz to 13.2 GHz	< -75 dBc for two -30 dBm signals at input mixer ^a and >50 kHz separation	+7.5 dBm TOI +12 dBm TOI, typical
13.2 GHz to 26.5 GHz	< -75 dBc for two -30 dBm signals at input mixer ^a and >50 kHz separation	+7.5 dBm TOI +11 dBm TOI, typical
Preamp On (<i>Option 1DS</i>) 10 MHz to 3 GHz		-16 dBm TOI, characteristic
Other Input Related Spurious		

	Specifications	Supplemental Information
Inband Responses		
>30 kHz offset	< -65 dBc for -20 dBm signal at input mixer ^a	
Out-of-band Responses	< -80 dBc for -10 dBm signal at input mixer ^a	

- a. Mixer power level (dBm) = input power (dBm) – input attenuation (dB).
- b. or signal below displayed average noise level.

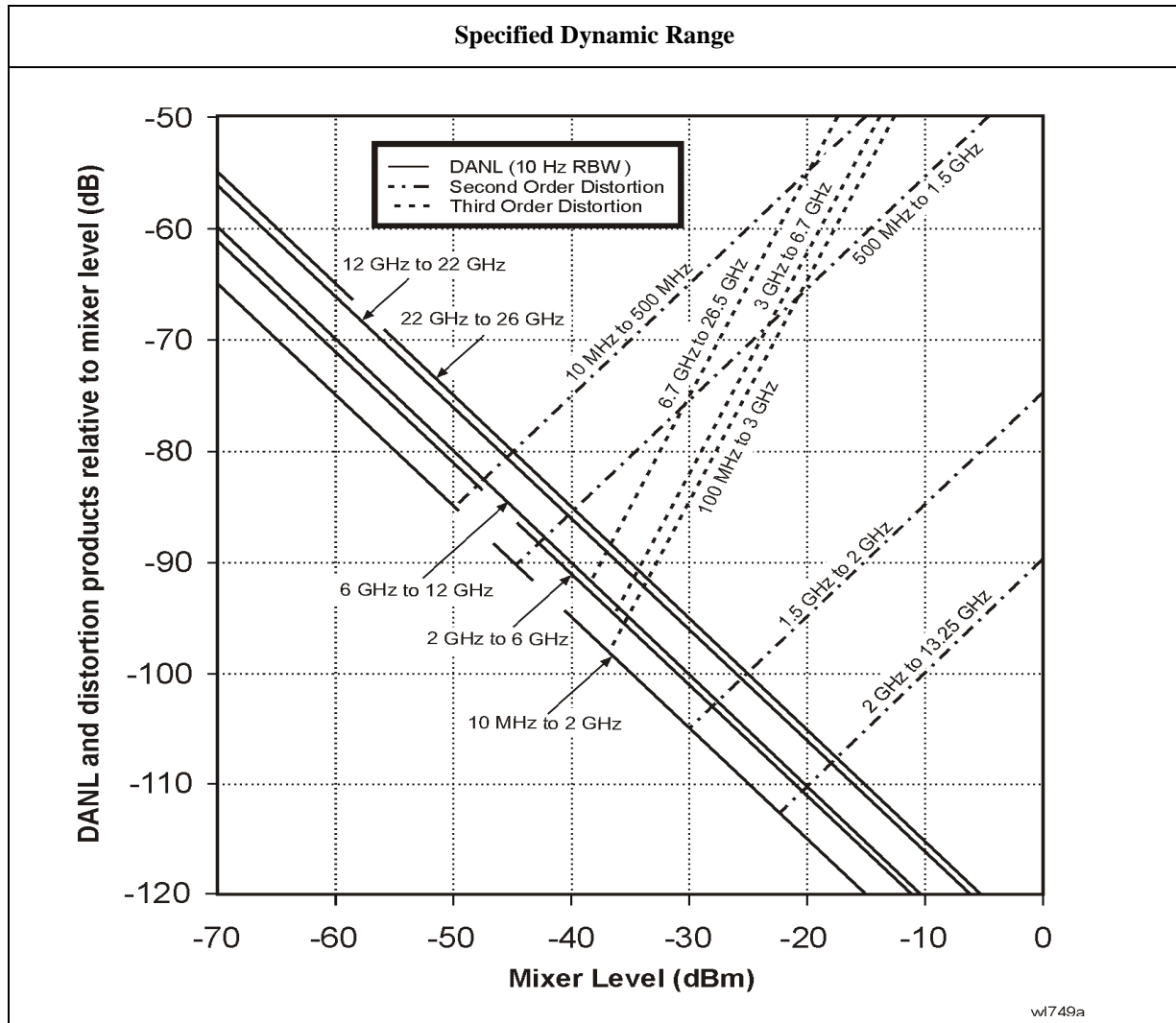

	Specifications	Supplemental Information
Residual Responses (Input terminated and 0 dB attenuation) 150 kHz to 6.7 GHz	< -90 dBm	

Options

Time Gated Spectrum Analysis (Option 1D6)

	Specifications	Supplemental Information
Gate Delay		
Range	1 μ s to 400 s	
Accuracy	$\pm(500 \text{ ns} + (0.01\% \times (\text{maximum of gate delay or length})))$	From gate trigger input to positive edge of gate output
Gate Length		
Range	1 μ s to 400 s	
Accuracy	$\pm(500 \text{ ns} + (0.01\% \times (\text{maximum of gate delay or length})))$	From positive edge to negative edge of gate output
Resolution	$((\text{maximum of gate delay or length in seconds})/65000)$ rounded up to nearest μ s	Dependent on the greater of gate delay or gate length
Additional Amplitude Error^a		
Log Scale	± 0.2 dB	
Linear Scale	$\pm 0.1\%$ of reference level	

a. While in gate mode.

Tracking Generator (Option 1DN)

The spectrum analyzer/tracking generator combination will meet its specification after a cable (8120-5148) and adapter are connected between RF OUT and INPUT and **Align Now**, **TG** has been run.

	Specifications	Supplemental Information
Warm-up	5 minutes	

	Specifications	Supplemental Information
Output Frequency Range	9 kHz to 3.0 GHz	

	Specifications	Supplemental Information
Minimum Resolution BW	1 kHz	Not usable with resolution bandwidths ≤ 300 Hz (<i>Option 1DR</i>)

	Specifications	Supplemental Information
Output Power Level		
Range	-2 to -66 dBm	
Resolution	0.1 dB	
Absolute Accuracy (at 50 MHz with coupled source attenuator, referenced to -20 dBm)	± 0.75 dB	
Vernier		
Range	8 dB	
Accuracy (with coupled source attenuator, 50 MHz, -20 dBm)		
Incremental	± 0.2 dB/dB	
Cumulative	± 0.5 dB, total	
Output Attenuator Range	0 to 56 dB in 8 dB steps	

	Specifications	Supplemental Information
Maximum Safe Reverse Level		+30 dBm (1 W), 50 Vdc, characteristic

	Specifications	Supplemental Information
Output Power Sweep		
Range	(-10 to -2 dBm) – (Source Attenuator Setting)	
Resolution	0.1 dB	
Accuracy (zero span)	<1 dB peak-to-peak	

	Specifications	Supplemental Information
Output Flatness		
Referenced to 50 MHz, -20 dBm		
9 kHz to 10 MHz	±3 dB	
10 MHz to 3 GHz	±2 dB	

	Specifications	Supplemental Information
Spurious Outputs		
(-2 dBm output)		
Harmonic Spurs		
TG Output 9 kHz to 20 kHz	≤ -15 dBc	
TG Output 20 kHz to 3 GHz	≤ -25 dBc	
Non-harmonic Spurs		
TG Output 9 kHz to 2 GHz	≤ -27 dBc	
TG Output 2 GHz to 3 GHz	≤ -23 dBc	
LO Feedthrough		
LO Frequency 3.921409 GHz to 6.9214 GHz	≤ -16 dBm	

	Specifications	Supplemental Information
Dynamic Range	Maximum Output Power Level – Displayed Average Noise Level	

	Specifications	Supplemental Information
Output Tracking Drift Swept Tracking Error		1.5 kHz/5 minute, characteristic Usable in 1 kHz RBW after 5 minutes of warm-up

	Specifications	Supplemental Information
RF Power-Off Residuals 9 kHz to 3 GHz		< -120 dBm, characteristic

	Specifications	Supplemental Information
Output Attenuator Repeatability 9 kHz to 300 MHz 300 MHz to 2 GHz 2 GHz to 3 GHz		±0.1 dB, characteristic ±0.2 dB, characteristic ±0.3 dB, characteristic

	Specifications	Supplemental Information
Output VSWR 0 dB attenuation ≥ 8 dB attenuation		<2.0:1, characteristic <1.5:1, characteristic

	Specifications	Supplemental Information
Output Attenuator Accuracy 0 dB 8 dB 16 dB 24 dB 32 dB 40 dB 48 dB 56 dB	Reference	±0.5 dB, characteristic ±0.5 dB, characteristic ±0.5 dB, characteristic ±0.6 dB, characteristic ±0.8 dB, characteristic ±1.0 dB, characteristic ±1.1 dB, characteristic

Tracking Generator Output Accuracy
Relative Accuracy (Referred to -20 dBm) = Output Attenuator Accuracy + Vernier Accuracy + Output Flatness
Absolute Accuracy = Relative Accuracy (Referred to -20 dBm) + Absolute Accuracy at 50 MHz

External Mixing (Option AYZ) [4E]

	Specifications		Supplemental Information
LO OUTPUT			
Frequency Range	2.9 to 7.1 GHz		
Power			When connected to external mixers with an HP/Agilent 5061-5458 cable, provides 14.5 to 16 dBm at the mixer, characteristic.
2.9 to 6.1 GHz	15.5 to 17 dBm		
20 to 30°C	15 to 17.5 dBm		
0 to 55°C	13 to 17.5 dBm		
2.9 to 7.1 GHz			
VSWR			<1.9:1, characteristic
IF INPUT			
Frequency Range			321.4 MHz ±5 MHz, characteristic
Maximum Safe Input Level			
ac			10 dBm, characteristic
dc			±10 V, characteristic
VSWR			<1.9:1, characteristic
Absolute Amplitude Accuracy ^a			
For Reference Levels from -10 to -60 dBm			
Amplitude Corrections	20 to 30°C	0 to 55°C	
15 to 30 dB	±1.0 dB	±1.5 dB	
>30 to 50 dB	±1.2 dB	±1.7 dB	
>50 to 60 dB	±1.4 dB	±1.9 dB	
1 dB Gain Compression Level ^b			-20 dBm, characteristic with -10 dBm reference level
Mixer Bias (IF INPUT)			
Voltage			
Maximum Range			±3.3 V, characteristic
Linear Compliant Range			±2 V, characteristic

	Specifications		Supplemental Information
Current (0 Ω load)			
Range	± 10 mA		
Resolution			< 20 μ A, characteristic
Accuracy	± 10 mA		$\pm(3\% + \text{Resolution})$, characteristic
Output Impedance			490 Ω , nominal

- a. Settings are: RBW 1 kHz; VBW 1 kHz; scale linear or log; span 2 kHz; sweep time coupled, sample detector, signal at reference level.
- b. With amplitude corrections 0 dB.

Bluetooth FM Demodulation (Option 106)

The FM demodulation characteristics will apply after an Align Now, FM Demod has been run.

	Specifications	Supplemental Information
Optimum Input Level		$\geq (-40 \text{ dBm} + \text{attenuator setting} - \text{preamp gain})$ and within 10 dB of the reference level
FM Deviation		
Range		$\pm 200 \text{ kHz}$, nominal
Resolution		Provides 400 Hz display annotation resolution, nominal
Accuracy ^a		$\pm 10 \text{ kHz}$, typical
Input level = -30 dBm		$\pm 4 \text{ kHz}$ with video averaging On and averages ≥ 25
Reference level = -30 dBm		
FM Rate = 500 kHz sine		
VBW = 3 MHz,		
RBW = 5 MHz,		
FM Deviation = 140 kHz		
Offset Error ^a		$\pm 1 \text{ kHz}$, typical
FM Bandwidth (-3 dB)		1.2 MHz, nominal

a. In time domain sweeps (span = 0 Hz).

Bluetooth Measurements Personality (Option 228)

The demodulation related nominals will apply after an Align Now, FM Demod has been run.

	Specifications	Supplemental Information
In-Band Frequency Range Bluetooth (ISM) Band	2400 to 2483.5 MHz	

	Specifications	Supplemental Information
Output Power (Option AYX or B7D)		
Range at RF Input	30 to -40 dBm	
(Option IDS)	30 to -60 dBm	
Absolute Amplitude Accuracy		See, "Absolute Amplitude Accuracy," on page 258.
Average type	Video, Power	
Average mode	Exponential, Repeat	
Trigger source	Video, RF burst ^a , External, Free Run	
Burst synch	RF Amplitude, Preamble ^b , None	

a. Requires Option B7E

b. Requires Option 106 Bluetooth FM demodulation.

	Specifications	Supplemental Information
Modulation Characteristics^a (Option 106 and AYX or B7D)		
Range at RF Input	30 to -40 dBm	
(Option IDS)	30 to -60 dBm	
FM Deviation		
Range		±200 kHz, nominal
Accuracy		±4 kHz, nominal (25 measurement averages, signal level > -30 dBm)
Payload data	11110000, 10101010, auto-detect	
Average mode	Exponential, Repeat	

	Specifications	Supplemental Information
Trigger source	Video, RF burst ^b , External, Free Run	
Burst synch	RF Amplitude, Preamble ^c , None	
Limits	$\Delta f_2/\Delta f_1$ lower, Δf_1 max lower/upper Δf_2	

- a. The DUT must have frequency hopping disabled.
- b. Requires Option B7E
- c. Requires Option 106 Bluetooth FM demodulation.

	Specifications	Supplemental Information
Carrier Frequency Drift ^a (Option 106 and AXX or B7D)		
Range at RF Input	30 to -40 dBm	
(Option 1DS)	30 to -60 dBm	
Measurement range		±100 kHz, nominal
Measurement accuracy		±4 kHz, nominal (25 measurement averages, signal level > -30 dBm)
Average mode	Exponential, Repeat	
Trigger source	Video, RF burst ^b , External, Free Run	
Burst synch	Preamble ^c , None	

- a. The DUT must have frequency hopping disabled.
- b. Requires Option B7E
- c. Requires Option 106 Bluetooth FM demodulation.

	Specifications	Supplemental Information
Initial Carrier Frequency Tolerance (ICTF) ^a (Option 106 and AXX or B7D)		
Range at RF Input	30 to -40 dBm	
(Option 1DS)	30 to -60 dBm	
Measurement range		±100 kHz, nominal
Measurement accuracy		±4 kHz, nominal (25 measurement averages, signal level > -30 dBm)

	Specifications	Supplemental Information
Average mode	Exponential, Repeat	
Trigger source	Video, RF burst ^b , External, Free Run	
Burst synch	RF Amplitude, Preamble ^c , None	
Limits	ICFT upper/lower	

- a. The DUT must have frequency hopping disabled.
- b. Requires Option B7E
- c. Requires Option 106 Bluetooth FM demodulation.

FM Demodulation (Option BAA)

The FM demodulation characteristics will apply after an **Align Now, FM Demod** has been run.

	Specifications	Supplemental Information
Optimum Input Level		$\geq (-60 \text{ dBm} + \text{attenuator setting} - \text{preamp gain})$ and within 30 dB of the reference level
FM Deviation		
Range		10 kHz to 1 MHz
Resolution		Provides 1 Hz display annotation resolution
FM Deviation Range		
10 kHz to 40 kHz		12 Hz, characteristic
>40 kHz to 200 kHz		60 Hz, characteristic
>200 kHz to 1 MHz		300 Hz, characteristic
Accuracy ^a		
FM Rate < FM BW/100, VBW $\geq (30 \times \text{FM Rate})$, RBW > the maximum of (30 \times FM deviation) or (30 \times FM Rate)		< (2% of FM deviation range + 2 \times Resolution), characteristic
Offset Error ^a		5% of FM Deviation Range + 300 Hz, characteristic
FM Bandwidth (-3 dB)		
FM Deviation Range		
10 kHz to 40 kHz		7.5 \times FM deviation range, characteristic
>40 kHz to 200 kHz		1.3 \times FM deviation range, characteristic
>200 kHz to 1 MHz		0.3 \times FM deviation range, characteristic

a. In time domain sweeps (span = 0 Hz).

TV Trigger and Picture On Screen (Option B7B)

Option BAA is required.

	Specifications	Supplemental Information
TV Trigger and Picture On Screen		TV Trigger initiates a sweep of the analyzer after the sync pulse of a selected line of a TV video field. Picture On Screen displays the TV picture on the analyzer display.
Amplitude Requirements TV Source: SA		Top 50% of linear display, characteristic
TV Source: EXT VIDEO IN		500 mVp-p to 2 Vp-p, characteristic
Compatible Standards	NTSC-M, NTSC-Japan, PAL-M, PAL-B,D,G,H,I, PAL-N, PAL-N Combination, SECAM-L	
Field Selection	Entire frame, even, odd	
Sync Polarity	Positive or negative	
TV Trigger		
Line Selection	1 to 525, or 1 to 625, standard dependent	

cdmaOne Measurement Personality (Option BAC)

Unless otherwise noted, all specifications are with RF input range auto, default cdmaOne measurement settings, and in the in-band frequency range. *Option B72* is required.

	Specifications	Supplemental Information
In-Band Frequency Range		
Cellular bands	824 to 870 MHz 869 to 925 MHz	
PCS bands	1715 to 1780 MHz 1805 to 1870 MHz 1850 to 1910 MHz 1930 to 1990 MHz	

	Specifications	Supplemental Information
Adjacent Channel Power Ratio^a		
Carrier power range at RF Input	30 to -20 dBm	
Dynamic range ^b		Referenced to average power of carrier in 1.23 MHz BW
Offset Frequency	Integration BW	
750 kHz	30 kHz	-70.0 dBc, characteristic
885 kHz	30 kHz	-73.5 dBc, characteristic
1.25625 MHz	12.5 kHz	-78.0 dBc, characteristic
1.98 MHz	30 kHz	-75.5 dBc, characteristic
2.75 MHz	1 MHz	-60.5 dBc, characteristic
Relative accuracy ^c	See Display Scale Fidelity	
Resolution	0.01 dB	

- a. This measurement is available with personality revisions of A.02.00 or later.
- b. IS-97A nominal base station test model levels (fraction of carrier power); Pilot: 0.20 (-7.0 dBc), Sync: 0.0471 (-13.3 dBc), Paging: 0.1882 (-7.3 dBc), 6 Traffic channels: 0.09412 (-10.3 dBc)
- c. Does not include uncertainty due to noise.

	Specifications	Supplemental Information
Channel Power (1.23 MHz Integration BW)		Integration BW range 1 kHz to 10 MHz
Range at RF Input	30 to -70 dBm	
Absolute power accuracy for in-band signal (Mean channel power at RF Input, plus any external attenuation, excluding mismatch error)		
Cellular Bands		
30 to -5 dBm 20 to 30 °C	±0.80 dB	±0.36 dB, typical
0 to 55 °C	±1.13 dB	
-5 to -25 dBm 20 to 30 °C	±0.77 dB	±0.33 dB, typical
0 to 55 °C	±1.10 dB	
-25 to -45 dBm 20 to 30 °C	±0.65 dB	±0.29 dB, typical
0 to 55 °C	±1.00 dB	
-45 to -55 dBm 20 to 30 °C	±0.72 dB	±0.36 dB, typical
0 to 55 °C	±1.01 dB	
-55 to -70 dBm 20 to 30 °C	±0.86 dB	±0.47 dB, typical
0 to 55 °C	±1.28 dB	
PCS Bands		
30 to -5 dBm 20 to 30 °C	±0.70 dB	±0.29 dB, typical
0 to 55 °C	±1.15 dB	
-5 to -25 dBm 20 to 30 °C	±0.67 dB	±0.26 dB, typical
0 to 55 °C	±1.11 dB	
-25 to -45 dBm 20 to 30 °C	±0.66 dB	±0.27 dB, typical
0 to 55 °C	±0.97 dB	
-45 to -55 dBm 20 to 30 °C	±0.73 dB	±0.34 dB, typical

	Specifications	Supplemental Information
0 to 55 °C	±0.98 dB	±0.45 dB, typical
-55 to -70 dBm 20 to 30 °C	±0.87 dB	
0 to 55 °C	±1.25 dB	

	Specifications	Supplemental Information
Channel power relative power accuracy (same channel, different Tx power, input attenuator fixed, RF input range manual).	See Display Scale Fidelity	

	Specifications	Supplemental Information
Receive Channel Power		
Absolute Power Accuracy		
Cellular bands		
30 to 0 dBm	±0.98 dB	±0.55 dB, typical
0 to -85 dBm	±2.02 dB	±1.33 dB, typical
PCS bands		
30 to 0 dB	±1.00 dB	±0.60 dB, typical
0 to -85 dBm	±1.52 dB	±0.84 dB, typical
Preamp (<i>Option 1DS</i>)		
Cellular and PCS bands		
30 to -80 dBm	±2.45 dB	±1.70 dB, typical
-80 to -100 dBm	±3.20 dB	±2.30 dB, typical

	Specifications	Supplemental Information
Occupied Bandwidth		
Carrier power range	30 to -45 dBm	
Frequency resolution of occupied BW	1.88 kHz	
Frequency accuracy of occupied BW (1.23 MHz channel BW)		±15 kHz, characteristic
Frequency resolution of delta frequency	3.75 kHz	

	Specifications	Supplemental Information
Frequency accuracy of delta frequency		$\pm (35 \text{ kHz} + \text{frequency reference error} \times \text{carrier frequency})$, characteristic

	Specifications	Supplemental Information
Code Domain Power (Requires <i>Options 1D5, B7D, and B7E</i> . Measurement interval ≥ 1.25 ms unless otherwise noted.)		
Carrier power range at RF Input (Pilot channel power > -11 dBc)	30 to -13 dBm	30 to -65 dBm ^a , characteristic
Preamp (<i>Option 1D5</i>)	30 to -30 dBm	30 to -82 dBm ^a , characteristic
Measurement interval range	0.5 ms to 26.67 ms	
Code domain power		
Display dynamic range	50 dB	
Accuracy (Walsh channel power within 20 dB of total power)		± 0.2 dB, typical
Displayed resolution	0.01 dB	
Other reported power parameters (dB referenced to total power)		Average active traffic, maximum inactive traffic, average inactive traffic, pilot, paging, sync channels
Carrier frequency error (Measurement interval ≥ 2.5 ms)		Excludes frequency reference error.
Input frequency error range	± 100 kHz	± 200 kHz, typical
Accuracy	± 10 Hz	± 7 Hz, typical
Displayed resolution	Four digits	
Estimated Rho		
Range	0.9 to 1.0	0.5 to 1.0 ^b
Accuracy (With 9 channels active over the specified range) ^c		± 0.02 , characteristic
Displayed resolution	0.0001	

	Specifications	Supplemental Information
Pilot time offset		From even second signal to start of PN sequence
Range	–13.33 ms to +13.33 ms	
Accuracy	±150 ns	
Displayed resolution	Four digits	
Code domain timing		Pilot to code channel time tolerance
Range	±200 ns	
Accuracy (IS-97A nominal power levels) ^d		±7 ns, typical
Code domain phase		Pilot to code channel phase tolerance
Range	±200 mrad	
Accuracy (IS-97A nominal power levels) ^d		±10 mrad, typical
Displays		Power Graph and Metrics, or Power, Timing, and Phase Graphs

- a. Performance may degrade outside of the specified carrier power range at RF input listed in the specifications column.
- b. Performance may degrade outside of the estimated rho range listed in the specifications column.
- c. The Active Set Threshold is less than all active channels, but greater than –20 dBc.
- d. IS-97A nominal base station test model levels (fraction of carrier power); Pilot: 0.20 (–7.0 dBc), Sync: 0.0471 (–13.3 dBc), Paging: 0.1882 (–7.3 dBc), 6 Traffic channels: 0.09412 (–10.3 dBc)

	Specifications	Supplemental Information
Modulation Accuracy (Rho) (Requires <i>Options 1D5, B7D,</i> and <i>B7E</i> . Measurement interval ≥1.25 ms unless otherwise noted.)		
Carrier power range at RF Input	30 to –28 dBm	30 to –70 dBm ^a , characteristic
Preamp (<i>Option 1DS</i>)	30 to –45 dBm	30 to –87 dBm ^a , characteristic
Measurement interval range	0.15 ms to 26.67 ms	
Rho (waveform quality)		
Range	0.9 to 1.0	0.5 to 1.0 ^b , characteristic
Accuracy		±0.0016, typical
Displayed resolution	0.0001	

	Specifications	Supplemental Information
Carrier frequency error (Measurement interval ≥ 2.5 ms)		Excludes frequency reference error
Input frequency error range	± 100 kHz	± 200 kHz, typical
Accuracy	± 10 Hz	± 7 Hz, typical
Displayed resolution	Four digits	
Pilot time offset		From even second signal to start of PN sequence
Range	-13.33 ms to $+13.33$ ms	
Accuracy	± 150 ns	
Displayed resolution	Four digits	
EVM		
Floor		3.8%, typical
Accuracy ^c		$\pm 1.1\%$, typical
Displayed Resolution	0.01%	
Carrier feedthrough		
Floor		-51 dBc, typical
Accuracy (Carrier feedthrough ≥ -43 dBc)		± 2.3 dB, typical
Displayed resolution	0.01 dB	
Magnitude error		
Floor		3.8%, typical
Accuracy ^c		$\pm 1.1\%$, typical
Displayed resolution	0.01%	
Phase error		
Accuracy ^c		± 0.65 degrees, typical
Displayed resolution	0.01 degrees	
Displays		Numeric results or Numeric results and IQ graph

- Performance may degrade outside of the specified carrier power range at RF input listed in the specifications column.
- Performance may degrade outside of the rho range listed in the specifications column.
- Accuracy does not include the effects of the EVM floor. The measurement variance increases as the result approaches the EVM floor.

	Specifications	Supplemental Information
Spur Close (In Band)		
Carrier power range at RF Input	30 to -12 dBm	
Dynamic range		
Input power		
30 to 25 dBm	55 dB	
25 to 20 dBm	50 dB	
20 to -12 dBm	46 dB	
Relative accuracy	$\pm(2.7 \text{ dB} + 0.01 \times (\text{dB from reference level}))$	$\pm(0.3 \text{ dB} + 0.01 \times (\text{dB from reference level}))$, typical
Displayed resolution	0.01 dB	

	Specifications	Supplemental Information
Out-of-Band Spurious^a		Refer to the Amplitude specifications section in this guide.

a. The out-of-band measurement is made with the user-defined tables with 20 frequency ranges each (up to the top 10 spurs per range, 100 spurs maximum). Table parameters include frequency range, RBW, video BW, detector type, and amplitude test limits.

	Specifications	Supplemental Information
Receiver Spurious Emissions		
Spurious emission power range	-20 to -83 dBm	
Preamp On (<i>Option 1DS</i>)	-40 to -101 dBm	
Absolute spurious emission power accuracy		
-20 to -60 dBm	$\pm 2.6 \text{ dB}$	$\pm 1.7 \text{ dB}$, typical
-60 to -83 dBm	$\pm 4.3 \text{ dB}$	$\pm 3.4 \text{ dB}$, typical
Preamp On (<i>Option 1DS</i>)		
-40 to -70 dBm	$\pm 3.6 \text{ dB}$	$\pm 2.6 \text{ dB}$, typical
-70 to -101 dBm	$\pm 5.0 \text{ dB}$	$\pm 3.9 \text{ dB}$, typical

	Specifications	Supplemental Information
External Correction External attenuation, external gain Range Resolution	-90 to 90 dB 0.01 dB	

	Specifications	Supplemental Information
Trigger Trigger source (Actual available choices dependent on measurement) (Option B7D and B7E) Delay trigger Range Resolution RF burst trigger level (Option B7E) Trigger slope (External and RF burst) Frame timing period Frame synchronizing source Frame synchronizing slope	Free run, external Add RF Burst, frame 0 to 500 ms 300 ns 0 to -25 dBc Positive/Negative 50 ns to 13.6533 s External frame sync Positive/Negative	Rear panel connector labelled EXT FRAME SYNC (Option B7D)

	Specifications	Supplemental Information
<p>Demod Trigger Source</p> <p>Even second input (Frame trigger only, <i>Option B7D</i> and <i>B7E</i>)</p> <p>PN offset range</p>	<p>0 to 511 x 64 [chips]</p>	<p>Rear panel connector labelled EXT FRAME SYNC</p>

GSM Measurement Personality (Option BAH)

Unless otherwise noted, all specifications are with RF input range auto, default GSM measurement settings, and in the in-band frequency range. *Option 1D6* and *Option B72* are required.

	Specifications	Supplemental Information
In-Band Frequency Range		
GSM 900, P-GSM bands	890 to 915 MHz 935 to 960 MHz	
GSM 900, E-GSM bands	880 to 915 MHz 925 to 960 MHz	
GSM 900, R-GSM bands	876 to 915 MHz 921 to 960 MHz	
DCS 1800 bands	1710 to 1785 MHz 1805 to 1880 MHz	
PCS 1900 bands	1850 to 1910 MHz 1930 to 1990 MHz	

	Specifications	Supplemental Information
Transmitter Power (Requires <i>Option B7D</i> or <i>AYX</i>)		
Range at RF Input	30 to -60 dBm	
Absolute power accuracy for in-band signal (Mean channel power at RF Input, plus any external attenuation, excluding mismatch error)		
P-GSM, E-GSM, and R-GSM Bands		
30 to -20 dBm 20 to 30 °C	±0.89 dB	±0.39 dB, typical
0 to 55 °C	±1.65 dB	
-20 to -30 dBm 20 to 30 °C	±0.82 dB	±0.38 dB, typical
0 to 55 °C	±1.48 dB	

	Specifications	Supplemental Information
-30 to -40 dBm 20 to 30 °C	±0.87 dB	±0.39 dB, typical
0 to 55 °C	±1.47 dB	
-40 to -50 dBm 20 to 30 °C	±1.06 dB	±0.57 dB, typical
0 to 55 °C	±1.60 dB	
-50 to -60 dBm 20 to 30 °C	±1.19 dB	±0.70 dB, typical
0 to 55 °C	±1.71 dB	
DCS 1800 and PCS 1900 Bands		
30 to -20 dBm 20 to 30 °C	±0.76 dB ^a	±0.28 dB ^a , typical
0 to 55 °C	±1.26 dB ^a	
-20 to -30 dBm 20 to 30 °C	±0.66 dB ^a	±0.27 dB ^a , typical
0 to 55 °C	±1.06 dB ^a	
-30 to -40 dBm 20 to 30 °C	±0.71 dB ^a	±0.26 dB ^a , typical
0 to 55 °C	±1.00 dB ^a	
-40 to -50 dBm 20 to 30 °C	±0.90 dB ^a	±0.44 dB ^a , typical
0 to 55 °C	±1.13 dB ^a	
-50 to -60 dBm 20 to 30 °C	±1.03 dB ^a	±0.57 dB ^a , typical
0 to 55 °C	±1.24 dB ^a	

a. For Option UKB, add 0.10 dB.

	Specifications	Supplemental Information
Transmitter Power (Requires <i>Option B7D</i> or <i>AYX</i>)		
Range at RF Input	30 to -60 dBm	

	Specifications	Supplemental Information
<p>Absolute power accuracy for in-band signal (Mean channel power at RF Input, plus any external attenuation, excluding mismatch error)</p> <p>P-GSM, E-GSM, and R-GSM Bands</p>		
<p>30 to -20 dBm 20 to 30 °C</p>	±0.81 dB	±0.38 dB, typical
<p>0 to 55 °C</p>	±1.31 dB	
<p>-20 to -30 dBm 20 to 30 °C</p>	±0.74 dB	±0.37 dB, typical
<p>0 to 55 °C</p>	±1.14 dB	
<p>-30 to -40 dBm 20 to 30 °C</p>	±0.79 dB	±0.37 dB, typical
<p>0 to 55 °C</p>	±1.11 dB	
<p>-40 to -50 dBm 20 to 30 °C</p>	±0.95 dB	±0.53 dB, typical
<p>0 to 55 °C</p>	±1.21 dB	
<p>-50 to -60 dBm 20 to 30 °C</p>	±1.09 dB	±0.66 dB, typical
<p>0 to 55 °C</p>	±1.33 dB	
<p>DCS 1800 and PCS 1900 Bands</p>		
<p>30 to -20 dBm 20 to 30 °C</p>	±0.68 dB	±0.28 dB, typical
<p>0 to 55 °C</p>	±1.30 dB	
<p>-20 to -30 dBm 20 to 30 °C</p>	±0.61 dB	±0.27 dB, typical
<p>0 to 55 °C</p>	±1.12 dB	
<p>-30 to -40 dBm 20 to 30 °C</p>	±0.66 dB	±0.27 dB, typical
<p>0 to 55 °C</p>	±0.99 dB	
<p>-40 to -50 dBm 20 to 30 °C</p>	±0.82 dB	±0.43 dB, typical
<p>0 to 55 °C</p>	±1.09 dB	

	Specifications	Supplemental Information
-50 to -60 dBm 20 to 30 °C	±0.96 dB	±0.56 dB, typical
0 to 55 °C	±1.21 dB	

	Specifications	Supplemental Information
Transmitter Power Relative Power Accuracy (same channel, different Tx power, input attenuator fixed, RF input range manual).	See Display Scale Fidelity	

	Specifications	Supplemental Information
Power versus Time (Requires <i>Option B7D</i> or <i>AYX</i>)		
Carrier power range at RF Input	30 to -23 dBm	30 to -55 dBm ^a , characteristic
Preamplifier On (<i>Option 1DS</i>)	30 to -40 dBm	30 to -72 dBm ^a , characteristic
Time resolution accuracy		±1% of sweep time, characteristic
Maximum record length	8 time slots	
Burst to mask uncertainty (Requires <i>Option B7D</i> and <i>B7E</i>)	±1.0 bit	

a. Performance may degrade outside of the specified carrier power range at RF input listed in the specifications column.

	Specifications	Supplemental Information
Output RF Spectrum		
Carrier power range at RF Input		
Offsets ≤1800 kHz, 30 kHz RBW		30 to -5 dBm, characteristic
Offsets >1800 kHz, 100 kHz RBW		30 to -4 dBm, characteristic
Reference power accuracy	Same as Transmitter Power measurement	
Relative accuracy ^a	See Display Scale Fidelity	

	Specifications	Supplemental Information
Spectrum due to modulation displayed dynamic range ^{b,c}		
100 kHz offset		30 dB, characteristic
200 kHz offset		60 dB, characteristic
250 kHz offset		60 dB, characteristic
400 kHz offset		70 dB, characteristic
600 kHz to 1.8 MHz offset		79 dB, characteristic
1.8 to 6.0 MHz offset		75 dB, characteristic
> 6 MHz offset		76 dB, characteristic
Swept Mode Dynamic Range		70 dB, characteristic
Spectrum due to switching transients displayed dynamic range ^{b,c}		
400 kHz offset		62 dB, characteristic
600 kHz offset		79 dB, characteristic
1200 kHz offset		79 dB, characteristic
1800 kHz offset		80 dB, characteristic
Swept Mode Dynamic Range		70 dB, characteristic

- a. Does not include uncertainty due to noise.
- b. Displayed dynamic range for specific frequency offsets—applies to CW signal at the specified offset. Dynamic range with a GSM signal may differ.
- c. Using default settings, the RBW filter has a corrected noise BW and impulse BW equivalent to five-pole synchronously tuned filter.

	Specifications	Supplemental Information
Phase and Frequency Error (Requires <i>Option 1D5, B7D, and B7E</i>)		
Carrier power range at RF Input	30 to -23 dBm	30 to -55 dBm ^a , characteristic
Preamp On (<i>Option 1DS</i>)	30 to -40 dBm	30 to -72 dBm ^a , characteristic
Phase error		
Range	0 to 180°	
Displayed resolution	0.01°	
Accuracy (Averages ≥10)		
Peak	±2.1°	±1.5°, typical

	Specifications	Supplemental Information
RMS Frequency error	$\pm 1.1^\circ$	$\pm 0.6^\circ$, typical Excludes frequency reference error
Initial frequency error range	± 100 kHz	
Accuracy (Averages ≥ 10)	± 10 Hz	± 5 Hz, typical
I/Q offset range	-10 to -46 dBc	
Burst sync time uncertainty	± 0.1 bit	
Displays		Numeric summary

- a. Performance may degrade outside of the specified carrier power range at RF input listed in the specifications column.

	Specifications	Supplemental Information
Transmit Band Spurious		
Carrier power range at RF Input		30 to -12 dBm, typical
Dynamic range		
Upper and lower adjacent segments		55 dB, characteristic
Upper and lower segments		44 dB, characteristic
Relative accuracy		$\pm(0.3 \text{ dB} + 0.01 \times (\text{dB from reference level}))$, characteristic
Displayed resolution	0.01 dB	

	Specifications	Supplemental Information
Out-of-Band Spurious^a		
Absolute Spurious Power Accuracy		Refer to the Amplitude specifications section in this guide.
Sensitivity ^b		
RBW		
1 kHz		-95 dBm, characteristic
3 kHz		-90 dBm, characteristic
10 kHz		-85 dBm, characteristic
30 kHz		-78 dBm, characteristic
100 kHz		-71 dBm, characteristic
300 kHz		-64 dBm, characteristic

	Specifications	Supplemental Information
1 MHz		-57 dBm, characteristic
3 MHz		-50 dBm, characteristic

- a. The out-of-band spurious measurement is made in accordance with the tables defined in the appropriate GSM specification document. The measurement is made over several frequency ranges (up to 10 spurs per range, 100 spurs maximum).
- b. With input attenuation of 5 dB. For all other attenuation settings, add (input attenuation - 5) dB.

	Specifications	Supplemental Information
Receive Band Spurious		
Spurious emission power range ^a		-20 to -73 dBm, characteristic
Preamp On (<i>Option IDS</i>)		-40 to -91 dBm, characteristic
Absolute spurious emission power accuracy		
-20 to -60 dBm		±1.9 dB, characteristic
-60 to -73 dBm		±2.5 dB, characteristic
Preamp on (<i>Option IDS</i>)		
-40 to -70 dBm		±2.8 dB, characteristic
-70 to -91 dBm		±4.1 dB, characteristic

- a. Requires bandpass filter centered on receive band, peak detector mode, 0 dB attenuation, 100 kHz RBW. Does not include insertion loss of bandpass filter.

	Specifications	Supplemental Information
Amplitude Range Control		RF Input Autorange, Manually set Max Total Pwr Manually set Input Atten

	Specifications	Supplemental Information
External Gain/Attenuation Correction		
Base gain, base attenuation, mobile gain, mobile attenuation		
Range	0 to 81.9 dB	
Resolution	0.01 dB	

	Specifications	Supplemental Information
Trigger		
Trigger source (Actual available choices dependent on measurement) (<i>Option B7D and B7E</i>)	Free run, external Add RF Burst and frame	
RF burst trigger (<i>Option B7E</i>)		
Peak carrier power range ^a	30 to -25 dBm	30 to -30 dBm, typical
Preamp On (<i>Option 1DS</i>)	30 to -45 dBm	30 to -50 dBm, typical
Trigger level range	0 to -25 dB relative to signal peak	

a. With trigger level set to -6 dB.

	Specifications	Supplemental Information
Burst Sync (Requires <i>Option AYX or B7D</i>)		
Source (Actual available choices dependent on measurement) (<i>Option B7D and B7E</i>)	RF amplitude, none Add training sequence	
Training sequence code		GSM defined 0 to 7 Auto (search) or Manual
Burst type		Normal (TCH and CCH) Sync (SCH) Access (RACH)

General

	Specifications	Supplemental Information
Temperature Range		
Operating	0 to 55 °C	Floppy disk 10 to 40 °C
Storage	-40 to 75 °C	

	Specifications	Supplemental Information
Audible Noise (ISO 7779)		
Sound Pressure at 25 °C		<40 dBa, (<4.6 Bels power)

	Specifications	Supplemental Information
Military Specification	Has been type tested to the environmental specifications of MIL-PRF-28800F class 3.	

	Specifications	Supplemental Information
EMI Compatibility	Conducted and radiated emission is in compliance with CISPR Pub. 11/1990 Group 1 Class A.	
<i>(Option 060)^a</i>	Conducted and radiated emission is in compliance with CISPR Pub. 11/1990 Group 1 Class B ^b .	

- a. Option 060 is not compatible with Option B7B nor Option 1DP.
b. Meets Class A performance during dc operation.

	Specifications	Supplemental Information
Immunity Testing		
Radiated Immunity		Testing was done at 3 V/m according to IEC 801-3/1984. When the analyzer tuned frequency is identical to the immunity test signal frequency, there may be signals of up to -60 dBm displayed on the screen.

	Specifications	Supplemental Information
Electrostatic Discharge		Air discharges of up to 8 kV were applied according to IEC 801-2/1991. Discharges to center pins of any of the connectors may cause damage to the associated circuitry.

	Specifications	Supplemental Information
Power Requirements		
ac Operation		
Voltage, frequency	90 to 132 Vrms, 47 to 440 Hz 195 to 250 Vrms, 47 to 66 Hz	
Power Consumption, On	<300 W	
Power Consumption, Standby	<5 W	
dc Operation		
Voltage	12 to 20 Vdc	
Power Consumption	<200 W	
Power Consumption, Standby	<100 mW	

	Specifications	Supplemental Information
Measurement Speed		
Local Measurement and Display Update rate ^a		
Sweep points = 101		≥ 40/s, characteristic
Sweep points = 401		≥ 28/s, characteristic
Remote Measurement and GPIB Transfer Rate ^{b,c}		
(Option A4H)		
Sweep points = 101		≥ 40/s, characteristic
Sweep points =401		≥ 28/s, characteristic

	Specifications	Supplemental Information
RF Center Frequency Tune, Measure, and GPIB Transfer Time ^{b,d} (Option A4H)		
Sweep points = 101		≤ 75 ms, characteristic
Sweep points = 401		≤ 90 ms, characteristic

- Factory preset, auto align Off, segmented sweep Off, fixed center frequency, RBW = 1 MHz, spans >10 MHz and ≤600 MHz, and stop frequency ≤3 GHz.
- Display Off (:DISPlay:ENABLE OFF), and 32-bit integer data format (:FORMat:DATA INT,32), if *Option AYX* or *A4J* is installed, disable sweep ramp, (:SYSem:PORTs:IFVSWEEP:ENABLE OFF), markers Off, single sweep, measured with IBM compatible PC with 550 MHz Pentium® III running Windows® NT 4.0, one meter GPIB cable, National Instruments PCI-GPIB card and NI-488.2 DLL.
- Factory preset, auto align Off, segmented sweep Off, fixed center frequency, RBW = 1 MHz, and span = 20 MHz, fixed center frequency, stop frequency ≤3 GHz, average of 100 measurements.
- Factory preset, auto align Off, segmented sweep Off, RBW = 1 MHz, span= 20 MHz, stop frequency ≤3 GHz, center frequency tune step size = 50 MHz.

	Specifications	Supplemental Information
Data Storage		
Internal		200 Traces or States ^a
External (10 to 40 °C) 3.5" 1.44 MB, MS-DOS® compatible floppy disk		200 Traces or States ^a

- When storing traces set to 401 points.

	Specifications	Supplemental Information
Downloadable Program Memory <i>(Option B72)</i>		2 MB available memory 10 MB available memory

	Specifications	Supplemental Information
Demod Tune and Listen Demod <i>(Option BAA or 106)</i> <i>(Option A4J or AYZ)</i> <i>(Option 106 or BAA)</i>	AM Add FM	Internal speaker, front-panel earphone jack and front-panel volume control. An uncalibrated demodulated signal is available on the AUX VIDEO OUT connector at the rear panel. An uncalibrated demodulated signal is available on the EXT VIDEO OUT connector at the rear panel.

	Specifications	Supplemental Information
Weight (without options) Net Shipping		17.1 kg (37.7 lb), characteristic 31.9 kg (70.3 lb), characteristic

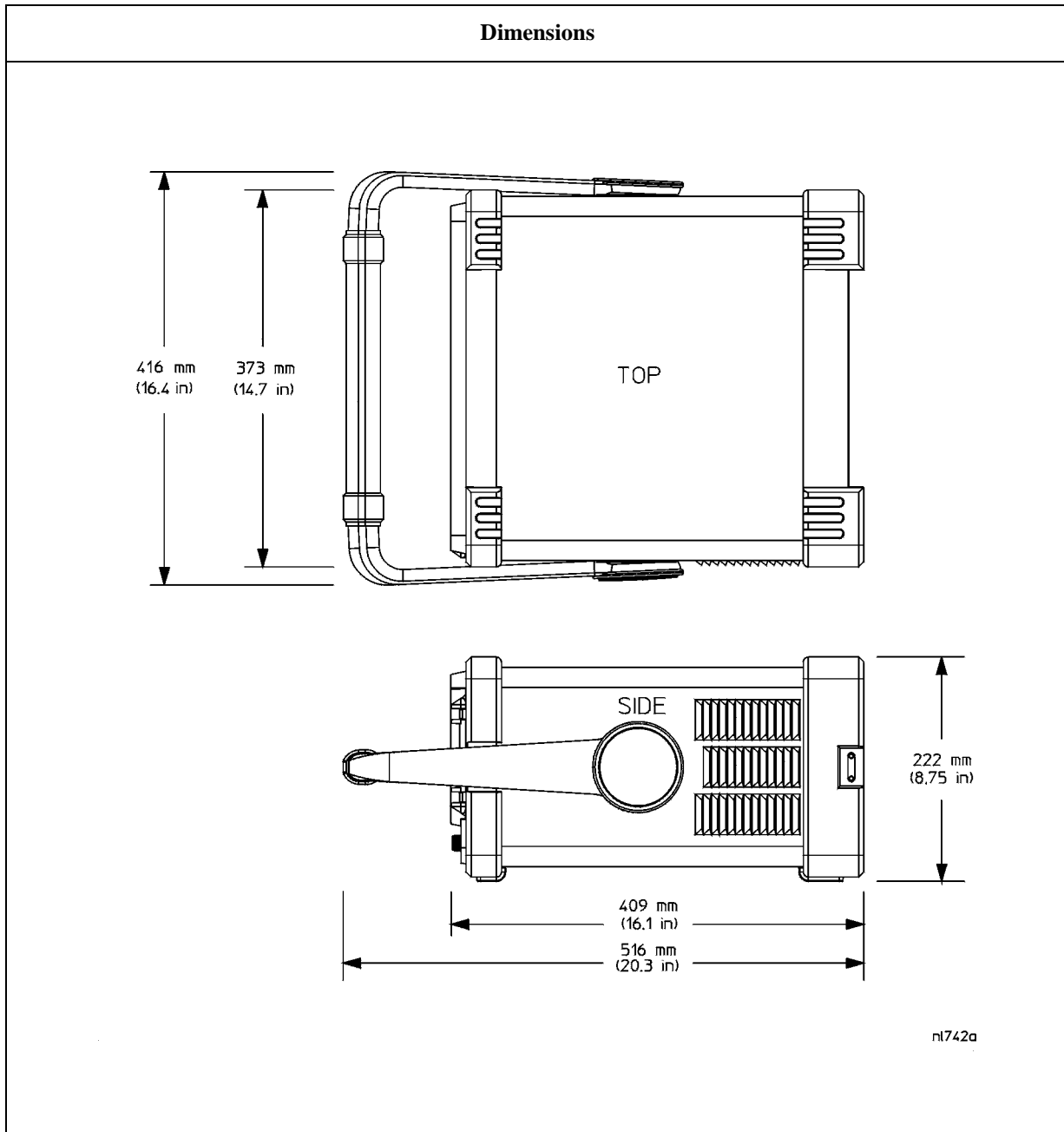

Inputs and Outputs

Front Panel

	Specifications	Supplemental Information
INPUT 50 Ω		
Connector (<i>Option BAB</i>)	Type-N female APC 3.5 male	
Impedance		50 Ω, nominal

	Specifications	Supplemental Information
RF OUT 50 Ω, (<i>Option 1DN</i>)		
Connector	Type-N female	
Impedance		50 Ω, nominal

	Specifications	Supplemental Information
AMPTD REF OUT^a		Amplitude Reference
Connector	BNC female	
Impedance		50 Ω, nominal
Frequency		50 MHz
Frequency Accuracy		Frequency reference error ^b
50 Ω Amplitude ^c		-20 dBm, nominal

- a. Turn the amplitude reference on/off by pressing the keys: **Input/Output, Amptd Ref Out**.
b. Frequency reference error = (aging rate × period of time since adjustment + settability + temperature stability).
c. The internal amplitude reference actual power is stored internally.

	Specifications	Supplemental Information
PROBE POWER		
Voltage/Current		+15 Vdc, ±7% at 150 mA max., characteristic -12.6 Vdc ±10% at 150 mA max., characteristic

	Specifications	Supplemental Information
EXT KEYBOARD^a		Used for entering screen titles and filenames only. Interface compatible with most IBM-compatible PC keyboards.
Connector	6-pin mini-DIN	

a. The feature is not implemented in firmware revisions prior to A.04.00.

	Specifications	Supplemental Information
Speaker		Front panel knob controls volume

	Specifications	Supplemental Information
Headphone		Front panel knob controls volume
Connector	3.5 mm (1/8 inch) miniature audio jack	
Power Output		0.2 W into 4 Ω , characteristic

	Specifications	Supplemental Information
IF INPUT (Option AYZ)		
Connector	SMA female	
Impedance		50 Ω , nominal
Frequency		321.4 MHz, characteristic

	Specifications	Supplemental Information
LO OUTPUT (Option AYZ)		
Connector	SMA female	
Impedance		50 Ω , nominal, must be terminated with 50 Ω

Rear Panel

	Specifications	Supplemental Information
10 MHz REF OUT		
Connector	BNC female	
Impedance		50 Ω , nominal

	Specifications	Supplemental Information
Output Amplitude		>0 dBm, characteristic

	Specifications	Supplemental Information
10 MHz REF IN		
Connector	BNC female	Note: Analyzer noise sidebands and spurious response performance may be affected by the quality of the external reference used.
Impedance		50 Ω, nominal
Input Amplitude Range		-15 to +10 dBm, characteristic
Frequency		10 MHz, nominal

	Specifications	Supplemental Information
EXT REF IN (Option B7E)		
Connector	BNC, female	
Impedance		50 Ω, nominal
Input amplitude range	-5 to 10 dBm	
Frequency	1 to 30 MHz, selectable	
Frequency lock range	$\pm 5 \times 10^{-6}$ of specified external reference input frequency	

	Specifications	Supplemental Information
10 MHz OUT (Option B7E)		
Connector	BNC, female	
Impedance		50 Ω, nominal
Frequency		10 MHz, nominal
Level		0 dBm when Option 10 MHz Out is On

	Specifications	Supplemental Information
GATE TRIG/EXT TRIG IN		
Connector	BNC female	
External Trigger Input		
Trigger Level		Selectable positive or negative edge initiates sweep in EXT TRIG mode (5 V TTL)
Gate Trigger Input (<i>Option 1D6</i>)		
Minimum Pulse Width		>30 ns (5 V TTL)

	Specifications	Supplemental Information
GATE/HI SWP OUT		
Connector	BNC female	
High Sweep Output		
Level		High = sweep ^a ; Low = retrace (5 V TTL)
Gate Output (<i>Option 1D6</i>)		
Level		High = gate on; Low = gate off (5 V TTL)

a. High sweep may be high longer than the indicated sweep times.

	Specifications	Supplemental Information
VGA OUTPUT		
Connector	VGA compatible, 15-pin mini D-SUB	
Format		VGA (31.5 kHz horizontal, 60 Hz vertical sync rates, non-interlaced) Analog RGB
Resolution	640 × 480	

	Specifications	Supplemental Information
AUX IF OUT <i>(Option A4J or AYZ)</i> Connector Frequency Amplitude (for signal at reference level and for reference levels – input attenuation + preamp gain of –10 to –70 dBm) Impedance	BNC female	RBW \geq 1 kHz 21.4 MHz, nominal –10 dBm (uncorrected), characteristic 50 Ω , nominal

	Specifications	Supplemental Information
AUX VIDEO OUT <i>(Option A4J or AYZ)</i> Connector Amplitude Range (into >10 k Ω)	BNC female	RBW \geq 1 kHz 0 to 1 V (uncorrected), characteristic

	Specifications	Supplemental Information
HI SWP IN <i>(Option A4J or AYZ)</i> Connector Input	BNC female	Open collector, low resets and holds the sweep (5 V TTL)

	Specifications	Supplemental Information
HI SWP OUT <i>(Option A4J or AYZ)</i> Connector Output	BNC female	High = sweep ^a , Low = retrace (5 V TTL)

a. High sweep may be high longer than the indicated sweep times.

	Specifications	Supplemental Information
SWP OUT <i>(Option A4J or AYX)</i>		
Connector	BNC female	
Amplitude		0 to +10 V ramp, characteristic

	Specifications	Supplemental Information
PRESEL TUNE OUTPUT		
Connector	BNC female	
Load Impedance (dc coupled)		> 10 k Ω , nominal
Range		0 to +10 V, characteristic
Sensitivity		
Internal Mixing		0.33 V/GHz of tuned frequency > 3 GHz, characteristic
External Mixing <i>(Option AYZ)</i>		1.5 V/GHz of tuned L.O. frequency, characteristic

	Specifications	Supplemental Information
GPIB Interface <i>(Option A4H)</i>		
Connector	IEEE-488 bus connector	
GPIB Codes		SH1, AH1, T6, SR1, RL1, PP0, DC1, C1, C2, C3 and C28

	Specifications	Supplemental Information
Serial Interface <i>(Option IAX)</i>		
Connector	9-pin D-SUB male	RS-232

	Specifications	Supplemental Information
Parallel Interface <i>(Option A4H or IAX)</i>		Printer port only
Connector	25-pin D-SUB female	

	Specifications	Supplemental Information
EXT VIDEO IN/TV TRIG OUT^a (<i>Option B7B or BAA</i>) Connector Impedance (<i>Option BAA without Option B7B</i>) (<i>Option BAA with Option B7B</i>) External Video Input Video Amplitude TV Trigger Output Amplitude	 BNC Female (75 Ω) 	EXT VIDEO IN is the Baseband composite video input for TV trigger and picture on screen. TV TRIG OUT is the TV trigger output. 75 Ω, nominal Feature not implemented 1 V _{p-p} , nominal, characteristic Positive edge indicates start of selected TV line after sync. pulse TTL (0 V and 3.4 V with 75 Ω series resistance), characteristic

a. This connector is labelled EXT VIDEO IN on older spectrum analyzers and EXT VIDEO IN/TV TRIG OUT on newer spectrum analyzers.

	Specifications	Supplemental Information
EXT VIDEO OUT (<i>Option B7B or BAA</i>) Connector Impedance (<i>Option BAA without Option B7B</i>) Amplitude (<i>Option BAA with Option B7B</i>) Amplitude TV Source: SA TV Source and EXT VIDEO IN (<i>Option 106</i>) Connector Impedance Amplitude	 BNC female (75 Ω) BNC female (75 Ω) 	Baseband video output RBW ≥ 1 kHz 75 Ω, nominal 0 to 1 V (uncorrected), characteristic 0 to 1 V (uncorrected), characteristic Same as level at EXT VIDEO IN/TV TRIG OUT, characteristic 75 Ω, nominal 0 to 1 V (uncorrected), characteristic

	Specifications	Supplemental Information
EXT FRAME SYNC <i>(Option B7D)</i>		
Connector	BNC, female	
Level		5 V TTL

Regulatory Information

CAUTION This product is designed for use in Installation Category II and Pollution Degree 2 per IEC 1010 and 664 respectively.

NOTE This product has been designed and tested in accordance with IEC Publication 1010, Safety Requirements for Electronic Measuring Apparatus, and has been supplied in a safe condition. The instruction documentation contains information and warnings which must be followed by the user to ensure safe operation and to maintain the product in a safe condition.



The CE mark is a registered trademark of the European Community (if accompanied by a year, it is the year when the design was proven).



The CSA mark is the Canadian Standards Association safety mark.

ISM 1-A

This is a symbol of an Industrial Scientific and Medical Group 1 Class A product. (CISPR 11, Clause 4)

Declaration of Conformity

DECLARATION OF CONFORMITY

According to ISO/IEC Guide 22 and CEN/CENELEC EN 45014

Manufacturer's Name: Agilent Technologies, Inc.

Manufacturer's Address: 1400 Fountaingrove Parkway
Santa Rosa, CA 95403-1799
USA

Declares that the products

Product Name: Spectrum Analyzer

Model Number: E4401B, E4402B, E4403B, E4404B,
E4405B, E4407B, E4408B, E4411B

Product Options: This declaration covers all options of the above products.

Conform to the following product specifications:

EMC: IEC 61326-1:1997+A1:1998 / EN 61326-1:1997+A1:1998

<u>Standard</u>	<u>Limit</u>
CISPR 11:1990 / EN 55011-1991	Group 1, Class A
IEC 61000-4-2:1995+A1998 / EN 61000-4-2:1995	4 kV CD, 8 kV AD
IEC 61000-4-3:1995 / EN 61000-4-3:1995	3 V/m, 80 - 1000 MHz
IEC 61000-4-4:1995 / EN 61000-4-4:1995	0.5 kV sig., 1 kV power
IEC 61000-4-5:1995 / EN 61000-4-5:1996	0.5 kV L-L, 1 kV L-G
IEC 61000-4-6:1996 / EN 61000-4-6:1998	3 V, 0.15 - 80 MHz
IEC 61000-4-11:1994 / EN 61000-4-11:1998	1 cycle, 100%

Safety: IEC 61010-1:1990 + A1:1992 + A2:1995 / EN 61010-1:1993 +A2:1995
CAN/CSA-C22.2 No. 1010.1-92

Supplementary Information:

The products herewith comply with the requirements of the Low Voltage Directive 73/23/EEC and the EMC Directive 89/336/EEC and carry the CE-marking accordingly.



Santa Rosa, CA, USA 17 April 2000

Greg Pfeiffer/Quality Engineering Manager

For further information, please contact your local Agilent Technologies sales office, agent or distributor.